

TILE ROOFS

BY JOHN SHEPHERD

Tile roofs made their first appearance in North America in the 1500s when Spanish missionaries introduced "Spanish" and "mission" tiles to the Southwest United States, Mexico and Latin America. Flat-style tiles were later introduced to North America as Northern Europeans settled along the East Coast. Concrete tiles, developed in Germany in the 1800s, made their first appearance in the U.S. toward the end of that same century.

While tile roofing systems currently make up only 4.5 to 5 percent of all steep-sloped roofing systems installed in the U.S., they also account for as much as 80 percent of the new residential construction in the sunbelt regions of the U.S. For a product that is so widely used, there appears to be a vast disparity in the quality and understanding of its installation. While not meant to be a definitive or complete guide to tile roof

DESIGN AND DESIGN CRITERIA

Tile Roof Materials and Styles

The materials used to manufacture roof tiles, for the most part, fall into four groups: concrete, clay, metal, and composite. For the purposes of this article we will focus primarily on concrete and clay tiles.

Concrete and clay roof tiles are generally defined by two generic groups: non-interlocking and interlocking. Also, the shape or profile of both concrete and clay tiles can be separated into three basic designs: low profile, high profile, and flat. Within each of these designs is a variety of styles, textures, and colors.

There are generally two types of high profile tiles. Typically called barrel tiles, these tiles are manufactured as either a one-piece barrel or "S" tile (made from both clay and concrete), or as a two-piece barrel or mission tile (made from clay only). Mission tile is also manufactured in both straight barrel and tapered barrel styles.

Flat tiles, which can have a flat shingle or flat ribbed shape, are made from both clay and concrete, and are available in styles known as slate, shake, and shingle. Low-profile tiles, while manufactured in many different styles, are similarly designed with a hip in the center of the tile.

Roof tiles are also manufactured with both glazed and unglazed finishes. With a wide ranging color selection, the use of glazed tiles allows a designer to specify the color of finish that complements the overall appearance of the project.

For additional information on the various types, styles, and colors of roof tiles, review the various tile manufacturers' designers' guides.

Building Code Requirements and Design Considerations

The three major building codes (UBC, SBC, and BOCA) have sections that deal with tile roof installation. While there are similarities in the tile roof section of each building code, there are also enough differences that a generic overview of the codes (as they apply to tile roofs in various regions of the country), cannot be adequately addressed in the space of this article. For the purpose of this article, any reference to the building code refers to the 1997 UBC.

When designing a roof system, local municipal building codes should be considered. Some local building codes, such as Dade County, Florida, and the City of Los Angeles, have significantly upgraded sections that deal with fire rating and wind uplift and attachment of roof systems. Much of the confusion revolving around the different building codes and installation requirements will soon be resolved.

The National Tile Roofing Manufacturers Association, in conjunction with ICBO and SBCCI, is in the process of developing a national standard for tile installation. This performance-based standard, which should become part of the 2000 International Building Code, will be broken down into three major sections: Basic installation (minimum standards), High Wind Regions installation, and Cold Region installation.

It is also important to understand that the building codes are considered the *minimum* standard by which a roof can be installed. Other important resources of design criteria for tile roof systems and flashings include manuals published by the National Roofing Contractors Association (NRCA) and the Sheet Metal and Air Conditioning Contractors National Association (SMACNA), along with those published by several regional roofing contractors' associations.

Manufacturer Application Instructions

While the resources listed above provide valuable guidelines in the design and installation of a tile roof system, the primary resource of design and installation assistance should come from the manufacturer's application instructions. In fact, if a design and/or the installation of the roof system fails to minimally comply with the manufacturer's application instructions, building code violations have occurred.

Occasionally during the course of construction defect litigation, some debate occurs as to whether the manufacturer's application instructions are voluntary guidelines or mandatory instructions. Section 1507.7 of the 1997 UBC states the following (as has every edition of the UBC since at least 1982): "Tile of clay or concrete shall comply with UBC Standard 15-5 and shall be installed in accordance with the manufacturer's instructions and Tables 15-D-1 and 15-D-2." This section leaves little doubt as to whether the tile manufacturer's instructions are voluntary or compulsory.

Roof Substrate

While there are different types of roof substrates that are acceptable for tile, solid wood decks (which include a minimum 15/32" plywood sheathing or an approved oriented strand board [OSB]), are by far the most common substrates used for tile roofs. Generally speaking, it is common practice to install solid sheathing on the steep roof sections of all new residential and commercial developments that will receive a tile roof. While it is common to find solid sheathing on many of the projects built in the last 20 years, there have been many projects built where spaced wood sheathing has been utilized as the substrate.

The building code does allow tile roofs to be installed over structural spaced sheathing (1" x 6" boards), but only when the roof has a minimum 4:12 slope. However, many cities (especially in the Southwest) have amended the building code with statutes that require the spaced sheathing be either filled-in with other wood or covered with solid sheathing.

Additionally, while some tile roof manufacturers allow re-roofing over spaced sheathing, a special underlayment (in accordance with acceptance criteria AC08) must first be installed.

Other acceptable types of roof decks include gypsum planks, nailable concrete, metal, and structural cement fiber.

ROOF SYSTEM COMPONENTS AND INSTALLATION

Underlayment

On tile roofs, the primary function of the underlayment is to prevent moisture from reaching the substrate. The underlayment must be installed in a manner that will shed water, with special attention given to corner transition areas, which must be sealed with roofing cement. The underlayment should also turn up all adjacent vertical surfaces a minimum of three to four inches (depending on the tile manufacturer) and extend over the open rake edge (or gable ends) of the roof a minimum of one inch. (See Figure 1.)

The type of underlayment installed on a tile roof system generally depends on several factors, including the roof slope, the tile manufacturer's long-term performance requirements, and the area's climatic conditions.

Typically, one layer of ASTM-rated, Type 30 asphalt-impregnated felt is installed on roofs with slopes of 3:12 or greater, though some manufacturers require the underlayment to consist of a minimum of two layers of Type 30 felt or one layer of Type 43 coated base sheet. Additionally, in areas with high annual rainfall, most manufacturers require the use of a Type 43 base sheet as a tile underlayment. The underlayment is to be secured with approved corrosion-resistant fasteners in a manner that allows the underlayment to resist wind damage. Staples should not be used to secure the underlayment. Special fastening techniques are required on non-nailable substrates.

The lapping of the underlayment is also affected by climatic conditions. In most areas, the underlayment should be lapped two inches horizontally (headlap) and six inches vertically (side lap). In both high volume rainfall areas, as well as cold and snow areas, a minimum four-inch horizontal headlap is required.

In cold weather regions, sealed underlayment (to protect from ice dams) extending from the eave edge up to a point 24 inches inside the exterior wall, is required by the building code to be installed prior to the tile underlayment. Traditionally, the sealed underlayment consisted of layers of underlayment cemented together. In recent years, it is common to use a self-adhering modified bitumen membrane to create this protective barrier.

Tile roofs can be applied as a decorative surface over roof areas with slopes as little as 2.5:12, provided an approved, three-ply, built-up roofing membrane or other waterproof underlayment system is first installed. (See Figure 2.) In both high volume rainfall areas and cold/snow areas, most tile manufacturers require a waterproof membrane system for all slopes below 4:12. In each of these settings, the tile is considered a decorative surface with the primary function of protecting the roof membrane from the ultraviolet rays of the sun.

In lieu of a built-up roof membrane as an underlayment on the low-slope decks, it is also acceptable, in most

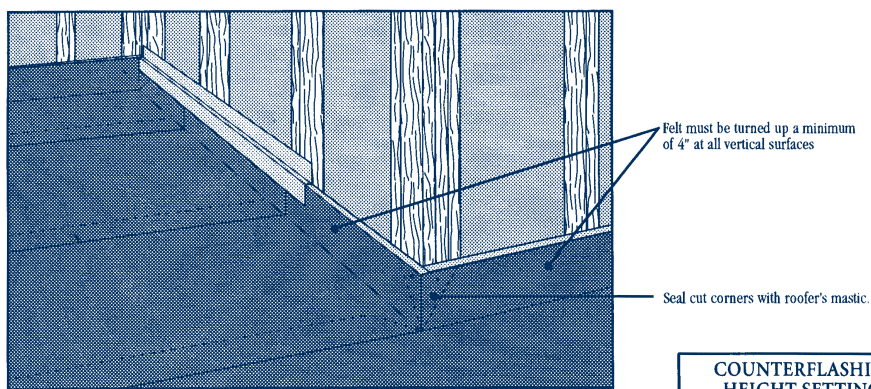

COUNTERFLASHING HEIGHT SETTINGS	
Flat Tiles	4"
Low Profile Tiles	5"
Mission Tiles	6"

Height setting is for the bottom edge of the Z-bar or other counterflashing.

Figure 1: Underlayment (All dimensions are approximate.)

GENERAL INSTALLATION DETAILS for pitches below 3:12

Tiles are to be used in a decorative way only below 3:12 pitch.

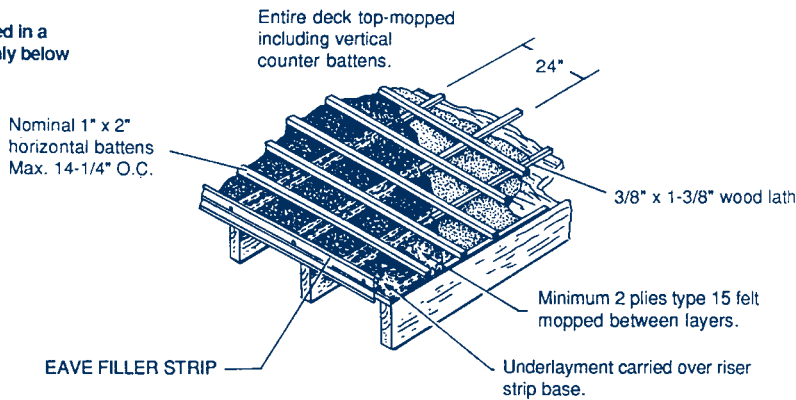

Figure 2: Low Pitched—Solid Deck Required (All dimensions are approximate.)

regions, to install a layer of self-adhering modified bitumen membrane as the tile roof underlayment. The use of an APP torch-applied membrane is generally not recommended as a tile roof underlayment. Most of the modified membrane manufacturers have not approved their materials to be used for this purpose. When considering one of these materials as a tile underlayment, make certain that the material manufacturer provides a written acceptance and acknowledges the intended use is appropriate for their product.

Tile Fasteners

For the most part, whether installing an interlocking or a non-interlocking tile, each piece of tile must be secured to the roof deck with a minimum of one fastener (for exceptions see batten section below), provided the weight of tile exceeds 7.5 pounds per square foot. On roofs with slopes of 7:12 or greater, two fasteners are required per tile (for tiles without anchor lugs). Two fasteners each are also required for tiles weighing less than

7.5 pounds per square foot. In snow country, two fasteners are required per tile on all slopes except when battens are used.

The type and length of fastener used to secure the tile to the roof deck depends on several factors, including the requirements of the building code, the type of roof deck, and the tile manufacturer.

For wood substrates, the building codes require corrosion-resistant fasteners (nails or screws) of not less than No. 11 gauge, with a minimum head size of 5/16 inch. There is considerable debate going on today with regards to the meaning of "corrosion-resistant." In the past this was taken to mean any electro-galvanized fastener. Lately some industry experts have been claiming that with regards to galvanized nails, only hot-dipped galvanized nails meet this standard. As a result of this debate, the National Tile Roofing

Manufacturers Association (NTRMA) has upgraded its standards of what constitutes a corrosion-resistant fastener. Henceforth, all tile roofs (with wood or metal substrates) are to be installed with fasteners that meet ASTM A-641/A-641M-98 Class 1.

While this is the new minimum standard for corrosion-resistant fasteners, before specifying a fastener for tile, first investigate the manufacturer's minimum requirements. Some tile manufacturers specify that only copper fasteners can be used to install their tiles. In general, it would be prudent to specify fasteners that will provide a longevity equivalent to the tile roof system (i.e., underlayment, flashings, etc.)

The length of the fastener required to install the tile depends wholly on the substrate. On wood decks the fastener must be long enough to penetrate into the battens or sheathing a minimum of 3/4", or through the thickness of the sheathing, whichever is less. For 1/2" plywood and OSB, this means the full diameter of the nail is to penetrate the underside of the sheathing. As a general note, only copper, stainless steel fasteners, or



RCI, Inc.
800-828-1902
www.rci-online.org

other approved materials should be utilized in corrosive environments such as in salt water coastal areas or industrial areas.

When installing tile over gypsum plank or nailable concrete decks, only spiral-threaded stainless steel or silicone bronze nails should be used. The fasteners should penetrate the deck at least 1/2" but no more than 3/4", and should never penetrate the underside of the deck.

Tile can also be applied over non-nailable concrete decks if pressure-treated attachment strips are embedded into the concrete during construction.

On a metal deck, the tiles should be secured to metal hat channels (which act as battens and an attachment point) with sheet metal screws that meet the above-referenced ASTM standard. Additionally, some manufacturers also require roofing cement to be applied over the screw head.

Tiles can be secured to a cementitious wood fiber deck with a corrosion-resistant, wire-tie system.

Special Anchorage Systems

Wire-tie fasteners and wind clips are the two most common types of special anchorage systems used in tile roof installation.

Wire-tie fastener systems, of which there are several different types, are commonly used to install clay tile over wood, concrete, and metal decks with exposed beam ceiling and/or for installing a staggered lay when using booster tiles.

The twisted wire, tile-tie method has a continuous element consisting of either two twisted wires or a metal strap extending from the eave to the ridge that is attached to the substrate as needed. The tiles are then attached to this continuous line with a tie wire. The single-line, tile-tie method continuously anchors the tiles through a series of interconnecting pre-formed wires.

Individual pieces of wire are used to secure both concrete and clay cut tiles in place at hips, valleys, and along confined

rakes.

When extra holding power and higher wind resistance are required in high wind areas or at eaves with elevations of greater than 40 feet, hurricane clips, wind locks, or butt hooks are used to better hold the tile in place. Each of these wind clips is secured directly to the roof deck and then hooked on to either the side (hurricane clips) or the bottom (wind locks and butt hooks) of each piece of tile.

Depending on local conditions, wind clips may be required on all of the tiles or on just the eave course of tiles.

Battens

One-by-two wood battens, which are used only when installing clay or concrete interlocking tiles with projecting lugs, are required on slopes of more than 7:12 and are optional on slopes of 7:12 or less. (See *Figure 3.*) Typically, only the perimeter tiles (within 36 inches of the eaves, rakes, ridge and hips) require fasteners when battens are used on roofs with slopes of less than 5:12. Only one fastener per tile every other row (plus the perimeter tiles) are required on slopes from 5:12 to less than 12:12. Roofs with battens and slopes of 12:12 require one fastener per tile.

While the building code normally requires two fasteners per tile (for all slopes) in snow areas, only one fastener per tile is required when battens are used in the roof system. However, the 1" x 2" battens will not suffice. The NTRMA requires that a counter batten system be installed for tile roofs applied in cold and snow regions of the country. The counter batten system consists of

1" x 4" planks that are installed vertically on the roof (aligned with the rafters) and spaced more than 24 inches apart. After a layer of underlayment is installed over the vertical battens, additional 1" x 4" planks, spaced as needed for tile, are installed horizontally across the roof. The tile is then secured with a minimum of one fastener each to these horizontal battens.

One common mistake that occurs when battens are used on a tile roof is to install the battens without the minimum drainage requirements. Inadequate drainage could lead to the deterioration of the underlayment and eventually the roof sheathing. Shims must be installed under the eight-foot long battens every 24 inches on center. Moisture-resistant 3/8" lath or strips of decay-resistant material, such as asphalt cap sheet or asphalt shingle, can be used as shims. An alternative drainage method is to cut the battens into four-foot sections and leave a 1/2" minimum break between each piece.

In order to secure cut tiles, it is recommended that batten extenders be utilized along the confined rake areas and in the valleys.

ALTERNATE TO 4' SLOTTED BATTEN METHOD:

SHIMMING 24" O.C. WITH MOISTURE RESISTANT 3/8" NOMINAL LATH OR STRIPS OF DECAY RESISTANT MATERIAL SUCH AS ASPHALT CAP SHEET OR ASPHALT SHINGLE

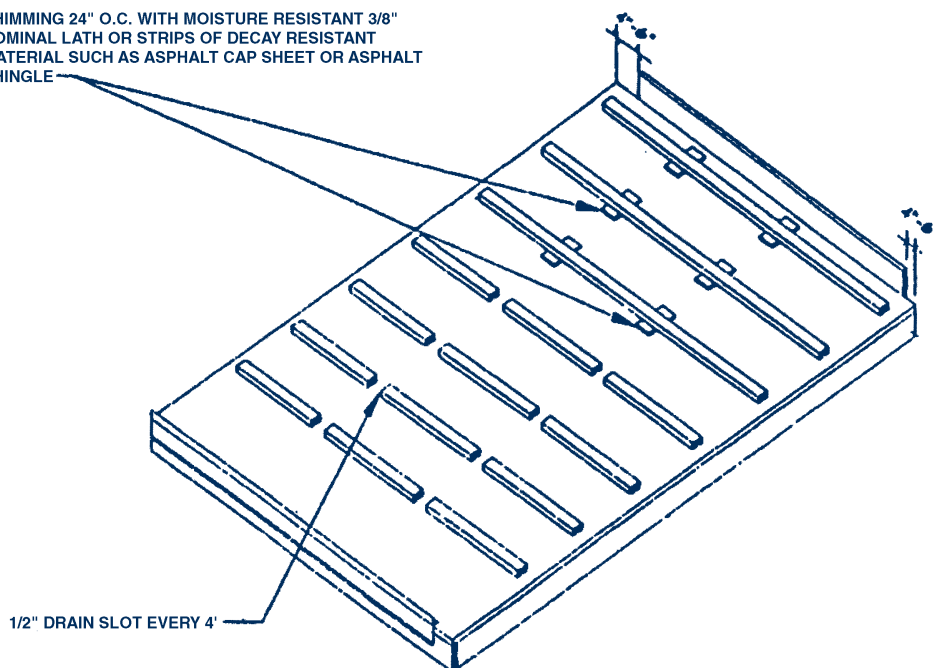

Figure 3: Batten Installation (All dimensions are approximate.)

TYPICAL ROOF FLASHINGS

The tile underlayment is not the only component that the roof system depends on to achieve a weathertight status. Sheet metal flashings play an integral part in bringing about a weathertight tile roof system. These flashings are used at many areas of the roof system, including, but not limited to the valleys, roof penetrations, headwalls, confined rake, at chimneys and skylights, and along eave and rake edges of the roof.

Each of the building codes has specific minimum requirements for sheet metal flashings. The UBC requires that all sheet metal be corrosion-resistant and a minimum 26-gauge galvanized metal, except for the valley metal which is to be a minimum 28-gauge galvanized or aluminum-coated zinc sheet metal or 16-ounce copper. The Southern Building Code Congress International (SBCCI) requires a minimum 26-gauge for all metal flashings, including the valley metal. Some tile manufacturers also require a minimum 26-gauge valley metal in heavy rain climates.

Flashings made from dead soft aluminum and/or 2.5 lb. lead are typically used for flashing extensions, headwall areas, and/or for secondary roof penetration flashings with high and low profile tiles.

Roof Penetrations

In all cases, two sheet metal flashings are required for each roof penetration. The primary flashing is installed prior to the tile and is shingle-lapped into the underlayment. As the field underlayment typically falls short of extending to the bottom of the flashing collar extension, an additional piece of underlayment (commonly referred to as a bib) must be installed in a shingle lap fashion over the top two-thirds of the flashing and underneath the first course of underlayment above the penetration.

The secondary sheet metal flashing is installed over the roof penetration and shingle-lapped into the courses of the tile roof system.

The width of the roof penetration flashing skirt depends on the type of material used to make the flashing. The NTRMA requires a minimum 12-inch wide skirt for a galvanized penetra-

tion flashing and a minimum 18-inch skirt on a lead or aluminum penetration flashing. The exposed, downslope portion of the secondary flashing is to be set in an approved sealant to resist wind uplift.

Valley Flashing

The valley metal used for all tile roofs should be a minimum 24" wide, although the Standard Building Code allows the use of valley metal as narrow as 16" if the side edges are mopped or sealed to the underlayment. Additionally, while valley metal is available in three different styles (single crown, double crown, and triple crown), single crown valleys are currently the most commonly used style of valley metal.

Prior to installing the valley metal and the field underlayment, a 36-inch wide sweat sheet (minimum #15 underlayment) must be installed in the valley area. The field underlayment should then be woven through the valley area.

After notching the bottom edge of the valley metal parallel to the eave, set the valley metal in place so that it extends a minimum of one inch beyond the eave edge. The valley metal should then be secured in place with clips 24 inches off center or by other approved methods. Lap sections of valley metal a minimum of six inches.

Sidewall, Skylight, and Chimney Flashing

Along with roof penetrations, the other most problematic area is found at transition areas. This includes transitions between both tile and sheet metal, and between two different sheet metal components, all of which are commonly found at chimneys, skylights, and elevated sidewalls. Even if the underlayment is properly installed, leaks can occur at and around these components as a result of the way the flashing is installed and fabricated.

A tile pan is typically installed along the sides of chimneys, skylights, and along confined rake areas. The tile pan typically comes in ten-foot lengths and has a minimum six-inch wide trough (width requirement varies by manufacturer) with a four-inch high vertical leg that rests against the vertical wall and a



RCI, Inc.
800-828-1902
www.rci-online.org

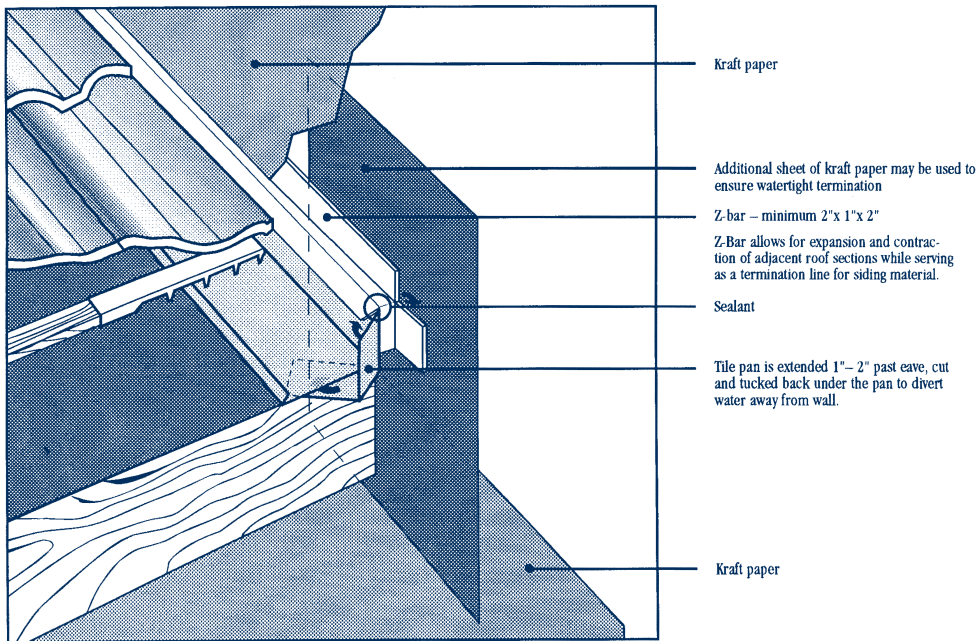

Figure 4: Tile Pan Transition at Eave (All dimensions are approximate.)

1/2" to 1" water rail along the outside edge. Care should be taken that tile fasteners do not penetrate the tile pan. Often this means using non-asphalt adhesive or wire ties to secure the cut tiles (that lay over the tile pan) in place. Additionally, in order to keep from flattening the tile pan water rail, the projecting lugs should be removed from the portion of the tile that extends over the tile pan.

One final note about the tile pan. In order to deflect the water run-off away from the adjacent wall surfaces, water diverters or kick-outs are also typically required at the eave ends of the tile pans. (See Figure 4.) Typically this diverter is pre-fabricated with soldered joints.

Another transition area is the upslope side of the chimney chase and the skylights. When the width of the chimney and/or skylight is 36" or wider, it is necessary to install a sloped sheet metal cricket. At widths under 36", a flat cricket or saddle can be installed on a level plane. It should be noted some tile manufacturers require sloping crickets only when the width of the

obstruction is greater than 48". The sheet metal should extend above the chimney a minimum of 14" and turn up the vertical face of the chimney a minimum of six inches. The cricket flashing extends down around the upper corners and overlaps the tile pan a minimum of four inches. An underlayment bib must be installed over the top portion of the cricket flashing prior to installing the tile.

Headwall Flashing and Weatherblocks

The type of headwall flashing used depends on both the type of tile and the desired finished appearance. A standard L-type metal, bent to the roof slope and counterflashed by a Z-bar, is commonly used for all three tile profiles. The space left below the headwall metal and a high profile tile is then usually filled with a mortar weatherblock. Closure of this area can also

be accomplished by using a flexible metal flashing, a pre-formed plastic or metal closure strip, or by an approved flexible membrane. The use of a weatherblock may not be required for mild climate areas but is generally recommended.

While it has become common practice in the Southwest to omit the Z-bar flashing at headwall areas, omission is discouraged by most tile manufacturers.

Eave Metal and Birdstop

In order to protect the edge of the roof sheathing, manufacturers recommend that a drip edge metal (typically 2" x 2") be installed along the eaves. With flat tiles and raised fascia boards, the metal becomes an anti-ponding metal as it extends farther up the roof and bridges the space behind the raised fascia board.

In order to provide a level appearance between the eave course of tile and the second course of tile, an eave riser must first be installed along the eave edge of the roof. (See Figure 5.) While a raised fascia board is often used to create an eave riser

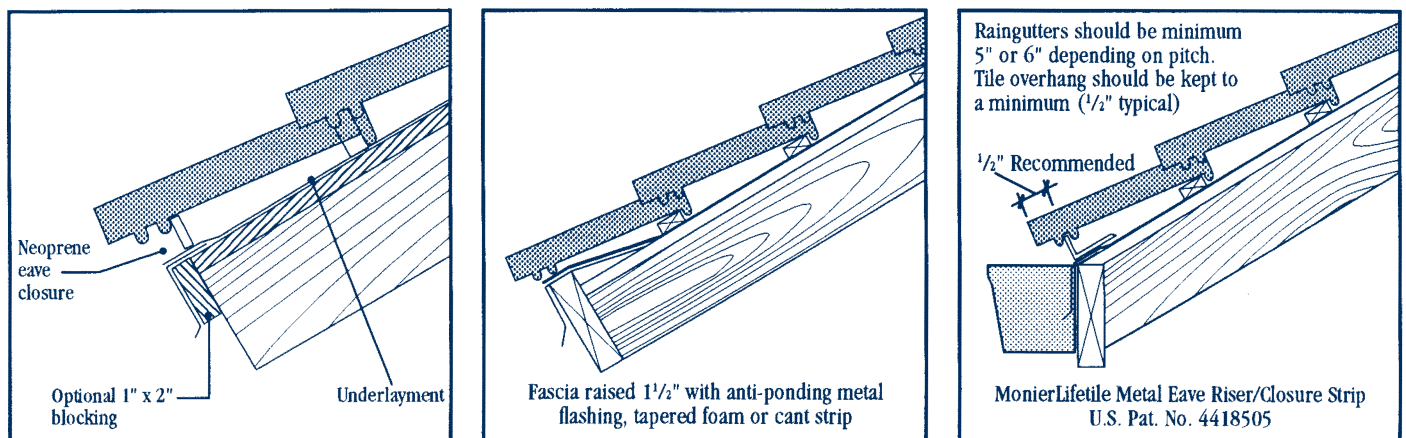

Figure 5: Eave Treatment (All dimensions are approximate.)

for flat tiles, a combination metal drip edge/eave riser can also be used for flat tiles. Though a metal birdstop is commonly used as an eave riser for low profile or high profile concrete tiles, low and high profile clay tile roof materials typically use a clay birdstop.

TILE INSTALLATION

Headlap, Exposure, and Layout

The exposure of the tile is determined by the length of the tile less the tile headlap. As the building code requires a minimum three-inch headlap for all tile roof systems, and the length of all tiles are not the same, it is crucial to check the length of each manufacturer's tile prior to determining the roof layout.

In order to provide a uniform appearance and to prevent overexposure of the tiles, the area between the eave and the ridge should be divided into equal tile courses. This process, called the roof layout, is different for each manufacturer and can affect the overall amount of tile needed for a project. This must be factored in when preparing a budget analysis for a roof installation.

Due to the layout process, tiles at headwall areas are often improperly set into place with exposures exceeding the maximum allowed for that tile. This problem can usually be resolved with a bit of foresight when laying out the tile by shorting the overall exposure so that an additional course of tile can be installed. At other times, it might be necessary to use a headwall flashing with a wider horizontal flange.

Tile Installation

All field tiles must be secured in place in compliance with the building code and according to each manufacturer's specific requirements. In all cases, cut tiles at the hip, ridge, valley, roof penetrations, headwall, and confined rake areas must be

secured in place with either tile adhesive or wire ties. At the headwall areas it is often acceptable to use a wood batten to hook the tile onto if nail placement is not possible. The fastener withdrawal resistance for each manufacturer's tile must be taken into account and compared to local wind conditions. Inadequate nailing could cause life safety issues during high wind conditions.

The field tiles should extend far enough up to the ridge so that they are covered a minimum of three inches by the trim tiles. All hip and ridge tiles are to be installed with the required headlap and are to be secured in place to a nailer with a minimum of one fastener. Additionally, the nose end of each piece of ridge trim tile must be covered with either roof cement or an approved tile adhesive. In high wind or severe climate areas, all trim tiles (hips, ridge, and open rakes) require adhesive on the nose ends.

When installing the rake tile, align the top edge with the bottom edge of the next course of field tile. All rake tiles must be secured in place with two corrosion-resistant fasteners (10d minimum). Additionally, prior to installing the rake tile, ensure that the tile underlayment extends over the edge of the roof. While the contractor may have originally completed this task, often another trade may come along and cut off the overhanging portion of the underlayment.



RCI, Inc.
800-828-1902
www.rci-online.org



RCI, Inc.
800-828-1902
www.rci-online.org

Weatherblock

On all tile profiles it is necessary to install a weatherblock at trim tile transition areas. This includes hip to ridge areas, ridge to valley areas, and rake to ridge areas. It is also necessary to apply a weatherblock under the hip and ridge tiles and at the headwall areas of high profile tiles (the weatherblock is optional on low profile tiles). While the commonly accepted practice is to install mortar as a weatherblock, there are sev-

eral other acceptable weatherblock materials. Some manufacturers and suppliers either make plastic or metal weatherblock closure strips. Most also accept an approved flexible material as a weatherblock. In all cases the lack of a weatherblock can lead to excessive deterioration of the tile underlayment.

SUMMARY

In preparation of an article like this, it becomes apparent how many differences there are between the various tile manufacturers' application instructions. When various code requirements and those of other applicable organizations are factored in, confusion for the designer and installer is understandable. While it is certainly possible to not only design but install a good-looking, long-performing, and weathertight tile roof system, it is a wonder that there are not more failures than there are. Fortunately, help is on the way.

With the new national tile standards from the NTRMA to be implemented in the year 2000, both designers and applicators, once trained in the national standards for tile installation, will in essence be trained to install the tile for each tile manufacturer. True, there will still be some minor differences between the various manufacturers' methods, but for the most part, each manufacturer will reference the national standard in its application instructions. This will go a long way toward helping tile roofs to continue to be a growing popular choice for a new roof system. ■

All figures courtesy of MonierLifeTile.



RCI, Inc.
800-828-1902
www.rci-online.org

ABOUT THE AUTHOR

John Shepherd has been actively involved in the roofing industry for the past 26 years, including 10 years as a licensed roofing contractor and the last five as a roof consultant. John investigates roofing system failures and provides litigation support services for Roofing & Waterproofing Forensics, Inc. in Yorba Linda, CA. A long-time member of RCI, John has passed the RRO and RRC exams. John and his wife, Joanne, have many common interests, including being active in their church, having fun with their Lhasa Apso, Brandi, snow skiing, photography, and working on their "city lights and oceanview" home.



JOHN SHEPHERD