

WATER PENETRATION IN BUILDING ENVELOPES

BY CHRISTINE BEALL, NCARB, CCS

Water penetration through a building enclosure depends on the simultaneous occurrence of three things:

- The presence of water.
- An opening through which water can enter.
- A physical force to move the water.

Water can be present as rain, melting snow, and soil moisture. Buildings have openings for egress, daylight, ventilation, and utilities, as well as unintentional gaps, voids, cracks, and joints. Several forces can cause water penetration through these openings (*Figure 1*):

- Gravity
- Air currents
- Capillary suction
- Surface tension
- Kinetic energy (momentum)
- Air pressure
- Hydrostatic pressure

Gravity—Joints and openings in horizontal surfaces are particularly vulnerable to water penetration caused by gravity.

Air Currents—Rain occurring in the absence of wind (or on the leeward side of a building) strikes only the horizontal and sloping surfaces of a building, while the vertical surfaces stay dry. Rain driven by wind, though, is carried at an angle by the air currents and strikes the walls as well. Wind patterns create swirling currents at the tops and corners of buildings, increasing the wetted area at these locations (*Figure 2*). The tops and edges of a building may be subjected to 20 to 30 times as much rain wetting as the center portion of a facade. This means that parapet walls are at a higher risk of wind-driven rain penetration than any other element of a building.

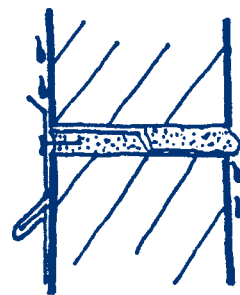

GRAVITY



AIR CURRENTS



CAPILLARY SUCTION

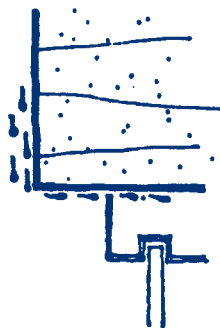

SURFACE TENSION



KINETIC ENERGY (MOMENTUM)

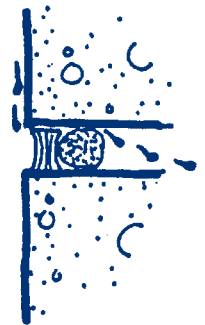

PRESSURE DIFFERENCE

Figure 1: Forces causing water penetration through building enclosures.

Capillary Suction—Small capillary passages (less than 1/8") in and between exterior building materials can create a suction force which draws in water. The smaller the passage, the greater the force and the higher the capillary potential. A material with fine capillary passages will attract and retain more water than one with larger capillary passages.

Surface Tension—Water clings to a surface by surface tension. Water that is flowing down the face of a vertical surface will turn and follow the profile of the surface flowing horizontal-

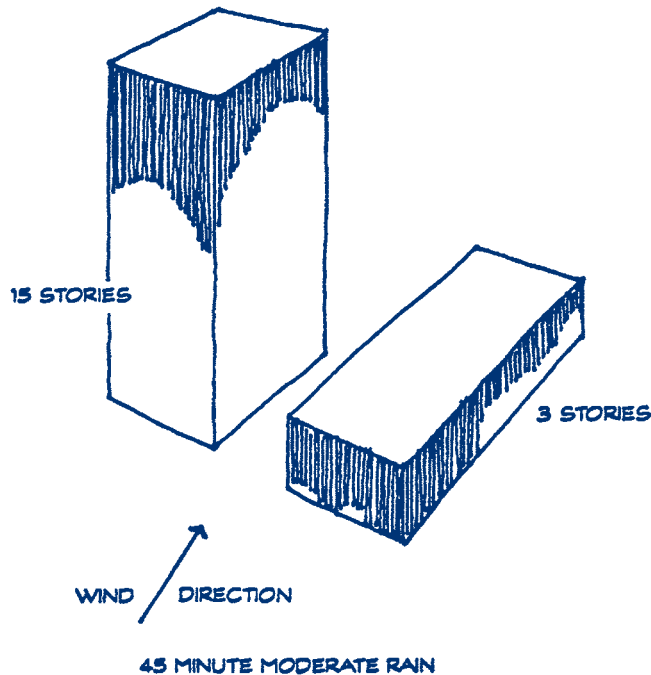
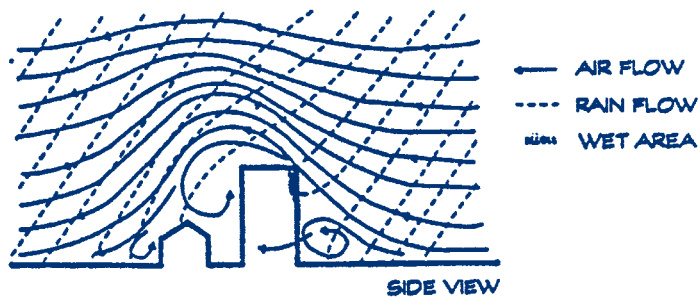

Figure 2: Wind increments wetting at building top and corners.

ly onto soffits and into cracks, joints and openings.

Kinetic Energy (Momentum)—The momentum of blowing rain will carry it directly through open windows, doors and joints. If the openings are small, or if the trajectory of the rain is such that it cannot enter directly, water can splash into openings—rain drops can splash from a sill through an open window or attic vent or splash into a joint.

Air Pressure—In addition to the force of wind driving rain against a surface and blowing it into openings, wind also creates air pressure differentials across the building envelope. The total air pressure difference between the outside and the inside of a wall is produced by the combined effects of wind, stack effect, and mechanical ventilation. Wind pressure has the most effect on rain penetration. The exact pressure differential at any given point on a wall or roof will vary depending on the location with respect to the wind direction and the shape of the building. Pressure differences on a wall can force water through even microscopic openings in a building envelope through a sort of pumping action, and wind pressure can even drive water uphill.

Hydrostatic Pressure—Both standing water and ground water can exert hydrostatic pressure against a building envelope.

Ground water in the soil exerts hydrostatic pressure against a basement waterproofing membrane. The deeper the structure, the greater the pressure exerted. Ponded water exerts gravitational pressure on a roof membrane, but also exerts hydrostatic pressure on the vertical flashings and joints. Continuous hydrostatic pressure places stringent requirements on waterproofing membranes and will cause failure at even small flaws or discontinuities.

PREVENTING WATER PROBLEMS

It is not possible to eliminate rain, snow, and ground water or the forces that move them, and it is impossible or impractical to eliminate all of the intentional and inadvertent openings and penetrations which occur in a building enclosure. It is possible, though, to mitigate the factors which contribute to water penetration by applying three basic moisture protection strategies.

1. Limit water penetration into a building or building enclosure with:
 - Barriers such as membranes and joint sealants.
 - Diversions such as sloping surfaces and gutters.
 - Screens such as projections and baffles.
2. Prevent water accumulation by providing:
 - Drainage.
 - Drying/evaporation.
 - Ventilation.
3. Neutralize the physical forces that transport water with:
 - Capillary breaks.
 - Drips.
 - Protected openings.
 - Rain screens.

Limiting Water Penetration

It is difficult to eliminate water penetration but relatively simple to limit it. Continuous roofing and waterproofing membranes form barriers to prevent water penetration through cracks and openings and into porous surfaces. The effectiveness of these barriers, however, depends on membrane continuity, the integrity of seams and joints, and properly detailed flashing at perimeters and penetrations. Elastomeric sealants prevent water penetration through large joints, but installation must be near perfect to form a complete barrier.

Water penetration can be limited by diverting the flow of water as it crosses the building enclosure. Sloped surfaces, for example, are effective in draining water quickly from a roof, coping, or sill so that it has less opportunity to penetrate through cracks or imperfections. Considering the inaccuracy of the construction process and the anticipated tolerances in erecting and assembling building components, most flat surfaces actually slope in one direction or another and the unintended slope can easily be in a direction which collects rather than sheds water.

Water penetration can also be limited by reducing the amount of water that strikes building surfaces and joints. Overhangs and projections can protect walls and openings from rain; louvers can shield an attic vent; baffles or batten strips can block joints; and gutters with downspouts can direct water away from foundation walls.



Figure 3: Shields and labyrinths keep water out of joints.

Preventing Water Accumulation

Water that penetrates a building enclosure may not necessarily cause damage if it can be drained or dried quickly. Flashing and weep holes are used in many different kinds of building systems to collect and drain water that has penetrated the exterior surface. Porous materials can be protected from excessive surface absorption with coatings or water repellent treatments, and drying can be expedited by allowing air circulation behind the cladding.

Neutralizing Forces

To resist water penetration caused by gravity flow, particular attention must be paid to horizontal surfaces. Wall caps or copings should be sloped to shed water, and the joints sealed with a high-performance sealant. Roofs should slope to drains, scuppers, or overhangs. Window sills and other projections should be sloped to the outside so that water will run off. A minimum 15-degree slope is generally recommended for sills.

To prevent rain penetration caused by the kinetic energy or momentum of the rain, roof overhangs and projections such as balconies and porches provide much the same protection as an umbrella, intercepting the rain drops before they strike the wall surface. Similarly, a shield in front of an opening will stop the rain. A shield can be incorporated in the joints between components of the cladding such as a batten strip on vertical wood siding, or the joint itself can be shaped or baffled to avoid a straight-through opening (Figure 3). It is not necessary for these devices to be sealed tightly to prevent the momentum of the rain from carrying it through the opening, so small imperfections are of little consequence.

To prevent the penetration of water caused by surface tension, the surface profile should be designed to break the surface

tension and force water to drip off. Since water cannot flow upward without some force being applied, a sharp change in direction to another vertical surface will cause the water to collect until its weight is sufficient that gravity overcomes the surface tension, and the water drips downward. Figure 4 shows several examples of drip profiles or "drips" that can be incorporated in masonry, precast, EIFS, and stucco systems.

Capillary suction can be eliminated by interrupting the passages with a sheet material such as metal flashing or a waterproofing membrane. Capillary suction can also be eliminated by introducing an air gap into the moisture path (Figure 5). Air gaps, drainage cavities, and gravel beds are effective capillary barriers

commonly used in drainage type wall systems such as masonry cavity walls, under floor slabs, and adjacent to basement walls. Air gaps in vertical walls or joints can also serve as drainage channels to direct penetrated water back to the outside.

To prevent the penetration of rain blown against a building by air currents, openings in the enclosure must be shielded in a manner similar to that discussed under kinetic energy forces.

Roof overhangs protect the tops of walls, balcony and porch

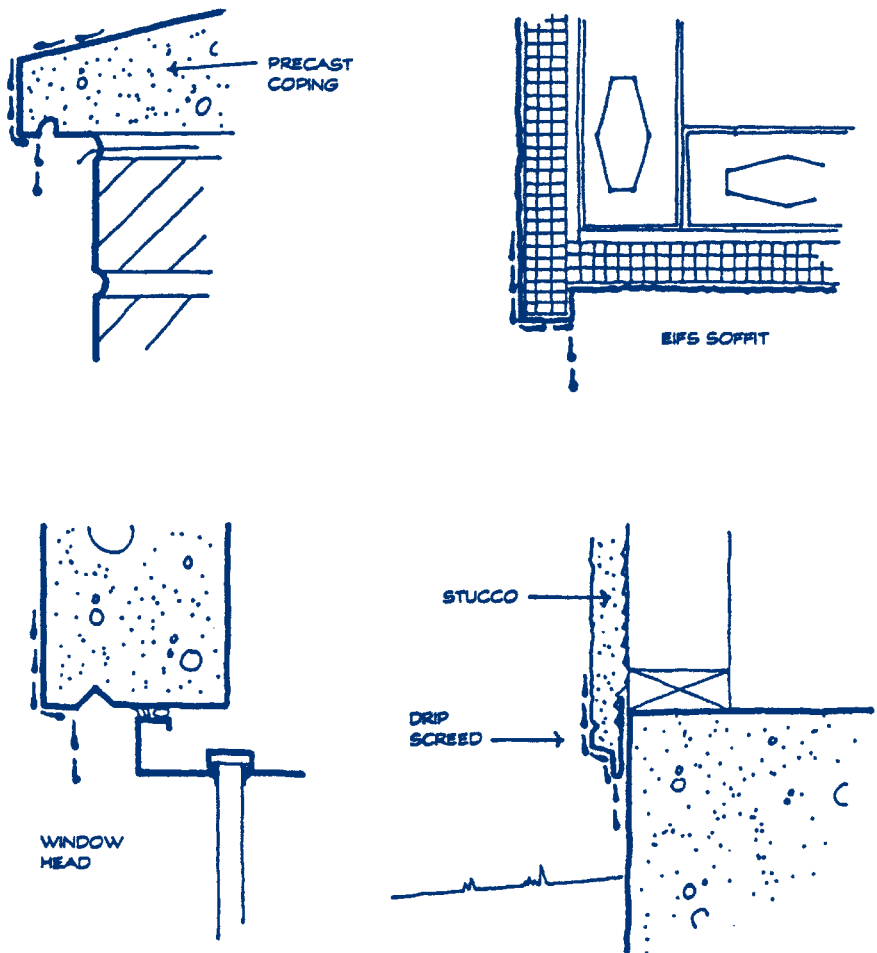

Figure 4: Drips break surface tension.

projections shield door openings, and awning-type windows allow natural ventilation while shielding the opening from blowing rain. Similarly, a shield incorporated in the joints between components of the cladding in the form of baffles or splines will

prevent rain from blowing into the opening.

Equalizing the pressure differentials on two opposite sides of a wall stops rain penetration caused by air pressure. Pressure equalization requires an air chamber between the inside and outside face of the enclosure that can be sealed against air leakage at the sides and at the inside plane. Pressure equalization principles were first developed for use in the curtain wall industry, but have been adapted with varying degrees of success to other cladding systems.

Wind pressure can also drive water through openings and up a vertical surface. Where wind pressures cannot be equalized, a back dam or flashing overlap must be of sufficient height to contain this water, depending on the expected wind speed and pressure.

Hydrostatic pressure leaks can be prevented by a waterproof barrier membrane and below-grade drainage. The hydrostatic pressure can be relieved with a permeable drainage mat or gravel layer adjacent to basement walls and below slabs (Figure 6).

BARRIERS, DRAINS, AND RAIN SCREENS

The design concepts which incorporate one or more of these three basic moisture protection strategies are barrier systems, drainage systems, and rain screen systems. Barrier systems attempt to limit the number of openings in a building envelope. Drainage systems limit the amount of water that can accumulate by controlling its flow. Rain screens neutralize some of the primary forces which move water through the enclosure.

Barrier Systems

Barrier systems are also sometimes referred to as "face seal" or "prime seal" methods of moisture protection. Barrier systems are commonly used in roofing, below-grade waterproofing, EIFS, architectural precast cladding, and metal building systems (Figure 7). Barrier systems rely exclusively on an air and water seal at the exterior weathering surface. All exterior joints and openings must be perfectly sealed or water will enter and be trapped inside the wall. To expect such perfection is unrealistic because a building that relies on joint sealants and surface treatments as its first and only line of defense will eventually leak.

Barrier systems are unforgiving of even minor errors in design or instal-

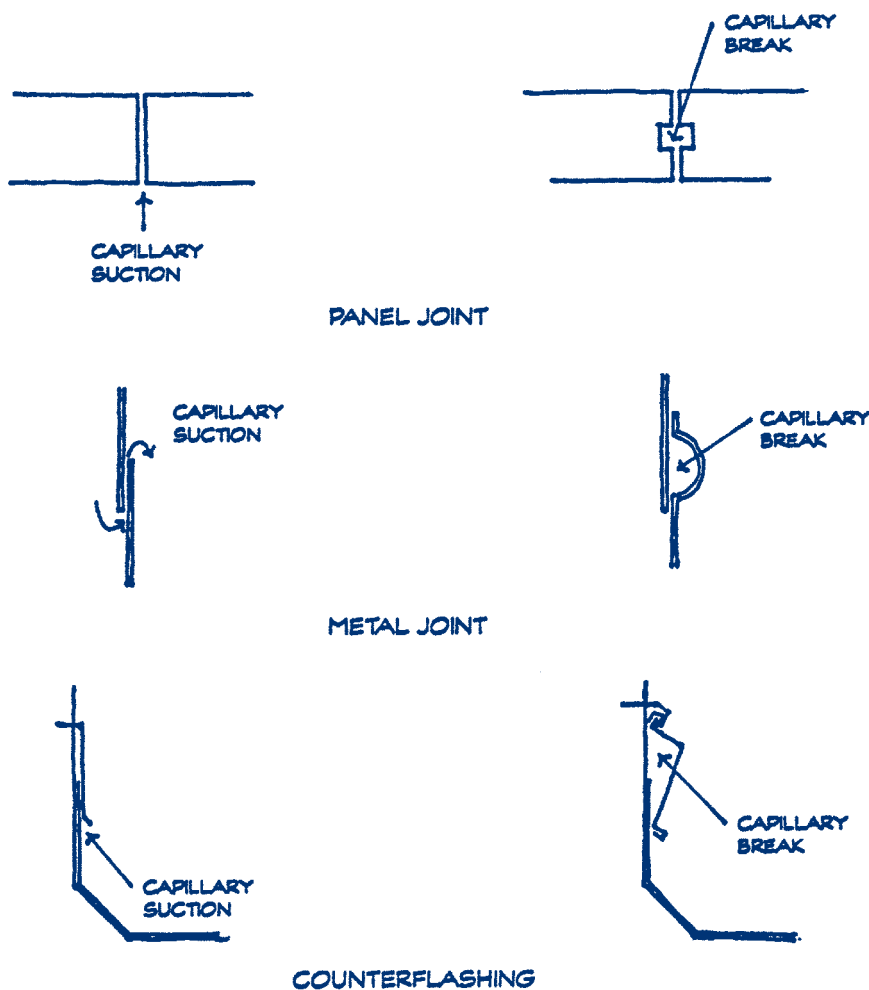

Figure 5: Capillary breaks prevent suction.

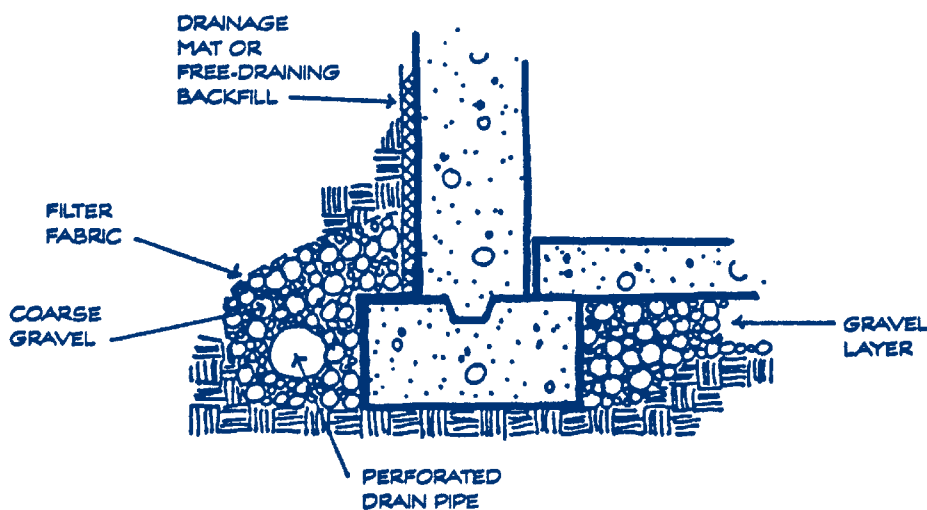

Figure 6: Hydrostatic pressure relief.

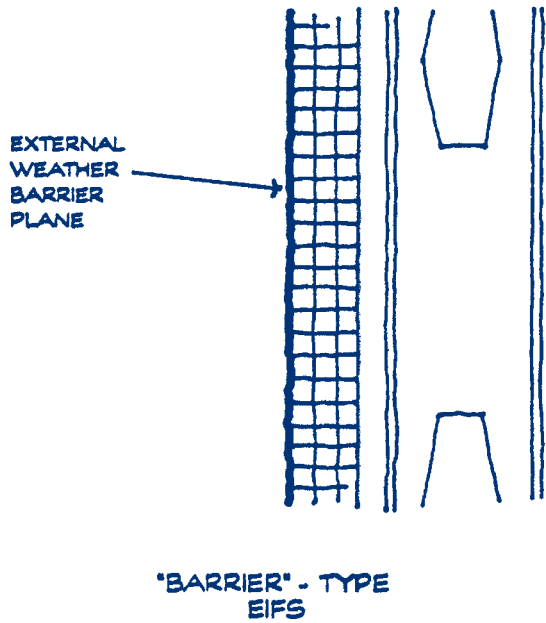

Figure 7: Rain barrier type systems.

lation. Exterior seals are difficult to achieve and maintain because of expansion and contraction and long-term exposure to ultraviolet radiation. Interstitial condensation from interior moisture sources can also be a problem since barrier systems do not incorporate any method of venting or drainage. Barrier systems are the least expensive method of providing initial weather resistance, but they require frequent maintenance of sealant joints to assure satisfactory performance.

Drainage Systems

Drainage systems incorporate a cavity or membrane behind the exterior weathering surface to collect moisture which may penetrate the outer plane. The cavity is then drained of penetrated water by flashing and/or weeps (Figure 8). Drainage systems can be used in masonry, precast concrete, stucco, metal roofs and metal windows. Drainage systems provide redundant protection where the exterior skin stops most of the incident rain but does not have to function as a perfect barrier. The internal collection and drainage system provides a second line of defense and prevents water from penetrating to the interior. Drainage systems are generally more expensive than barrier systems, but when properly designed and constructed, they require less maintenance, have a longer expected service life, and provide a higher level of protection against water penetration.

Drainage systems are more forgiving than barrier systems but can still experience water penetration problems if the flashing and weeps are not adequately designed and installed.

Rain Screen Systems

Rain screen systems create a pressure-equalized cavity behind the cladding and must include a struc-

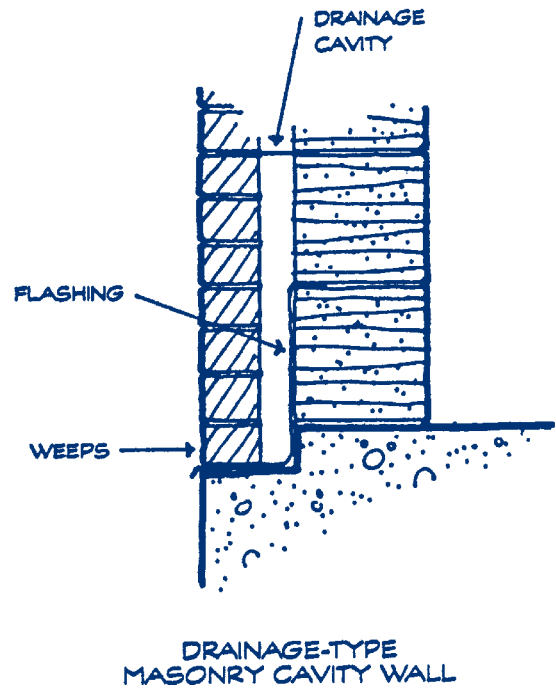

Figure 8: Drainage type systems.

turally supported air barrier, a sealed and compartmented air chamber, adequate drains, and external vents. Wind pressure is transmitted to the cavity through drain and vent holes, while an air barrier and sealed compartments confine the cavity pressure and prevent air from moving to the building interior or around corners (Figure 9).

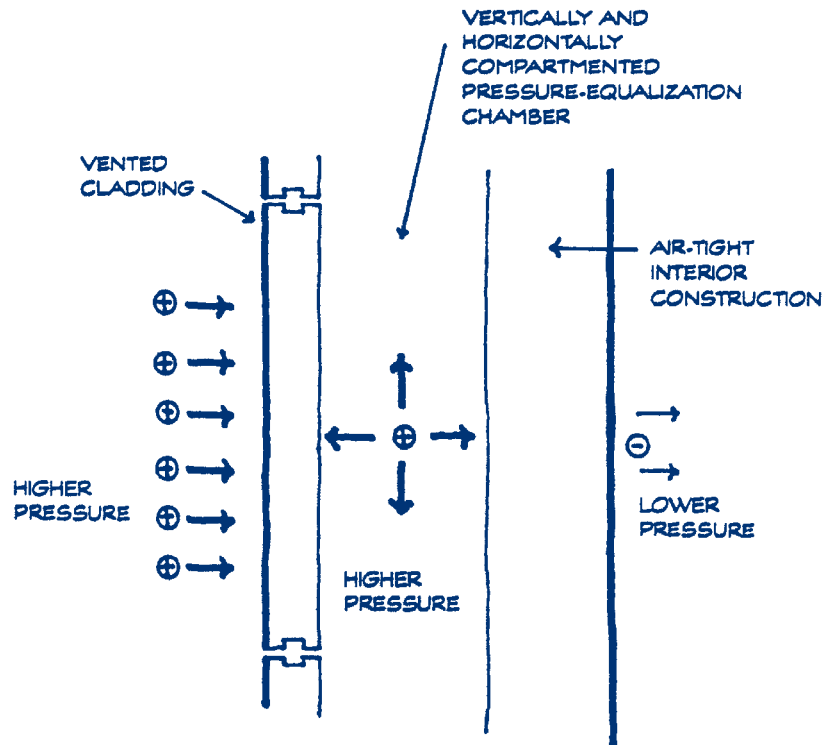

Figure 9: Rain screen system concept.

As a rule of thumb, intentional openings in the outer wall should be ten times the area of the unintentional openings in the air barrier. The force producing rain penetration and the quantity of water penetrating the exterior surface is thus reduced to about one tenth of what it would have been. The air chamber may also serve as a drainage cavity for collecting penetrated water and directing it back to the outside.

Rain screens are high performance wall systems. They provide multiple layers of protection by limiting water penetration, collecting and draining penetrated water, and moving the primary air seal from the weathering surface of the wall to a protected location within the wall. Rain screen systems are more expensive than barrier and drainage wall systems, but they also have the lowest maintenance and the highest safety factor in protecting against water infiltration.

Combining Protective Strategies

In reality, many enclosure systems use a combination of methods to resist water penetration. A building might consist of barrier membrane waterproofing below grade with a drainage medium provided as a capillary break to hydrostatic pressure; a sloping roof to shed snow and rain; a pressure-equalized aluminum curtain wall system; and a masonry cavity wall with flashing and weeps for drainage. A combination of protective strategies can be selected based on the type of building and its occupancy requirements, the severity of macro- and micro-environmental exposure, and appropriateness for the type of building system under consideration. ■

**This article is based on material from Ms. Beall's book *Thermal and Moisture Protection Manual* (McGrawHill, 1999), reprinted here with permission.

REFERENCES

- Allen, Edward, *Architectural Detailing: Function, Constructability, Aesthetics*, New York, John Wiley & Sons, 1993.
- Lstiburek, Joseph and John Carmody, *Moisture Control Handbook*, New York: Van Nostrand Reinhold, 1993.
- Quirouette, R.L. "Rain Penetration Control," *The Construction Specifier*, (November 1994), pp. 48-56.
- American Architectural Manufacturers Association, *Aluminum Curtain Wall Design Guide Manual*, Palatine, Illinois, AAMA, 1979.
- Beall, Christine, *Masonry Design and Detailing*, 4th ed., New York: McGraw-Hill, 1997.

ABOUT THE AUTHOR

Christine Beall is a consulting architect from Lake McQueeney, Texas, who specializes in problems of architectural detailing, specifications, cladding systems, and moisture protection. She has written extensively on a variety of design and construction topics, and has published several books including the *Thermal and Moisture Protection Manual* on which this article is based. Christine is a member of ASTM, The Masonry Society, and the Association for Preservation Technology. She has been a speaker at numerous RCI functions, including the March 2000 RCI convention in Reno. Visit her website at www.christinebeall.com.