

## A B S T R A C T

Reduced government spending in recent years has led to private ownership of specialty sports facilities such as hockey arenas and multi-purpose complexes incorporating pools and several other activities under the same roof. The pressure to derive more income from these facilities has led to all-day, year-round operation and to the combining of several activities under the same roof.

This new reality is creating new challenges for designers, owners, and operators of these facilities. The design conditions for one portion of the facility can be very different from another. Roof and other envelope failures are exposing the weaknesses/limitations of traditional design and construction techniques when applied in this context. Building owners and operators are confused by the symptoms and complex underlying causes of the problems being experienced.

The main case study deals with the investigation of a roof and exterior envelope problem. Water ingress was occurring through the ceiling assembly of a year-round hockey arena. Water accumulation in the insulation layer above a suspended, low-emissivity ceiling raised concerns about possible collapse of the ceiling. In addition, dripping water was causing damage to the ice surface, creating an annoyance for spectators, and a constant headache for maintenance staff.

Among several viable options, the best solution to the water ingress was found in the form of fans. The solution required no renovation of the existing interior or exterior roof elements, had a neutral effect on operating costs, and cost about five percent of a roof replacement.

Similar symptoms of water accumulation in building roof and ceiling assemblies can be manifest in very different climatic and building conditions and can be solved by modifying pressure gradients. This paper is applicable to other scenarios, including:

- In hot, humid climates, the upper floors of air conditioned, high-rise buildings are subjected to stack effect-related infiltration which can deposit water on cooler interior surfaces.
- In hot, humid climates, the moisture drive from exterior to interior becomes very strong when historic masonry buildings are retrofitted with air conditioning but without envelope upgrades. The moisture transmission through the masonry leaches salts from the mortar and deposits them on inner surfaces as efflorescence. This slowly damages the mortar and deteriorates the masonry in ways not previously experienced by the structure.
- In most climates, freezer buildings operate with interior temperatures lower than exterior for the majority of year. The upper levels (even of a single-story building) are subjected to stack effect-related infiltration of warm, humid air which can deposit water on cooler interior surfaces.
- In most climates, swimming pool enclosures are susceptible to moisture accumulations in ceiling assemblies, even at moderately cool temperatures, due to the high humidity.

# SOLVING ROOF LEAKS with FANS

BY STEVEN MURRAY, P. ENG.

## Roof Leaks

Occasionally a roof leak which seems to defy logic will present itself. It will be active on a warm, sunny day and dry on a rainy day. Sometimes the water barely drips, and other times it gushes. Inspection and testing seem to reveal nothing. There is no apparent problem with the waterproof layer. Flood testing fails to reproduce the observed leakage. But the symptoms continue. Even interior humidity doesn't seem to be a concern. The design has accounted for the condensation potential by including a vapor retarder in the assembly. The interior is even air conditioned or dehumidified.

So what else could be causing the leakage problems?

This paper describes a case study involving the investigation of an ice hockey arena with symptoms similar to those described above and how the solution was found through the use of fans. The paper discusses the climatic, architectural, economic, and operational aspects of the building which contributed to the water leakage problems. Several common situations are also addressed in which the same symptoms can occur and the same logic can be used to solve and prevent similar problems.

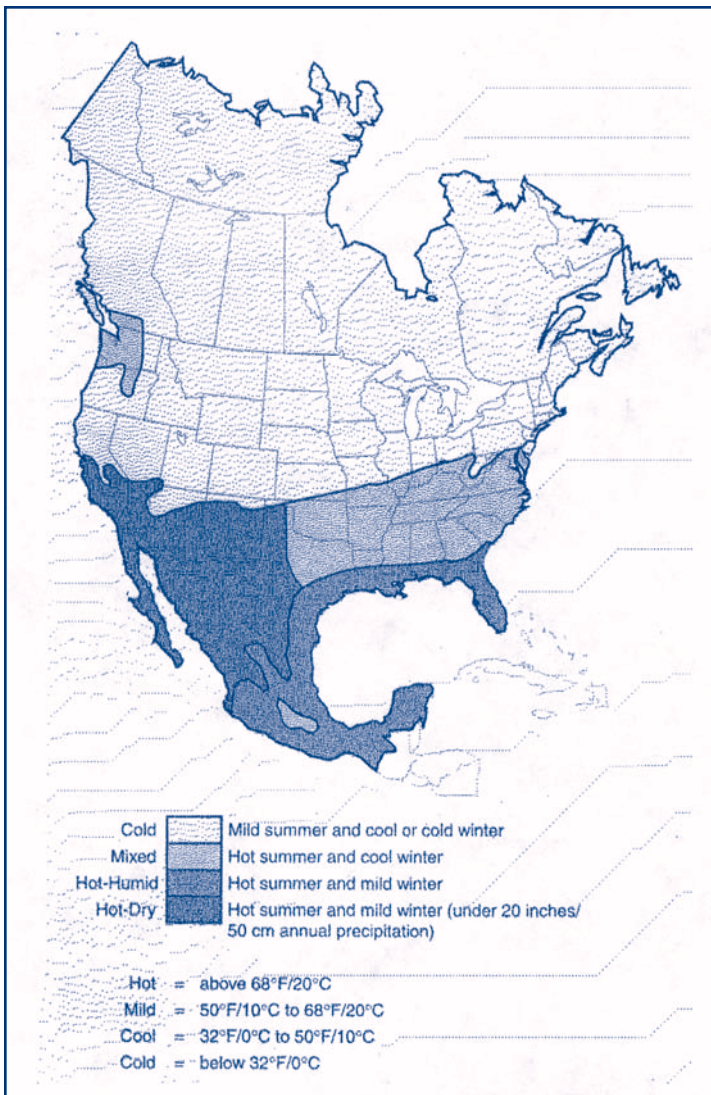

Figure 1: Climate Zones<sup>1</sup>

## FACTORS AFFECTING BUILDING PERFORMANCE

### Climate - Temperature and Moisture Control

North America is dominated by three main climate zones: Cold (heating) climates, Hot (cooling) climates, and Mixed climates. See Figure 1.

Superimposed on these temperature zones are annual rainfall zones. There are four main rainfall zones: Dry (under 30" annual precipitation); Moderate (30"-50" annual precipitation); Wet (50"-60" annual precipitation); and Temperate Rain Forest (over 60" annual precipitation). See Figure 2.

Each climate presents different challenges in regards to building design and roofing design in particular. The heating and/or cooling requirements determine the levels of thermal insulation required. The quantity of rainfall received determines the type of roof system and exterior wall cladding necessary to resist rain water penetration.

In cold climates, heating the interior spaces to a comfortable level in winter is one of the primary design goals. This means controlling heat loss from the interior to the exterior by the use of thermal insulation is necessary to control energy costs. Under

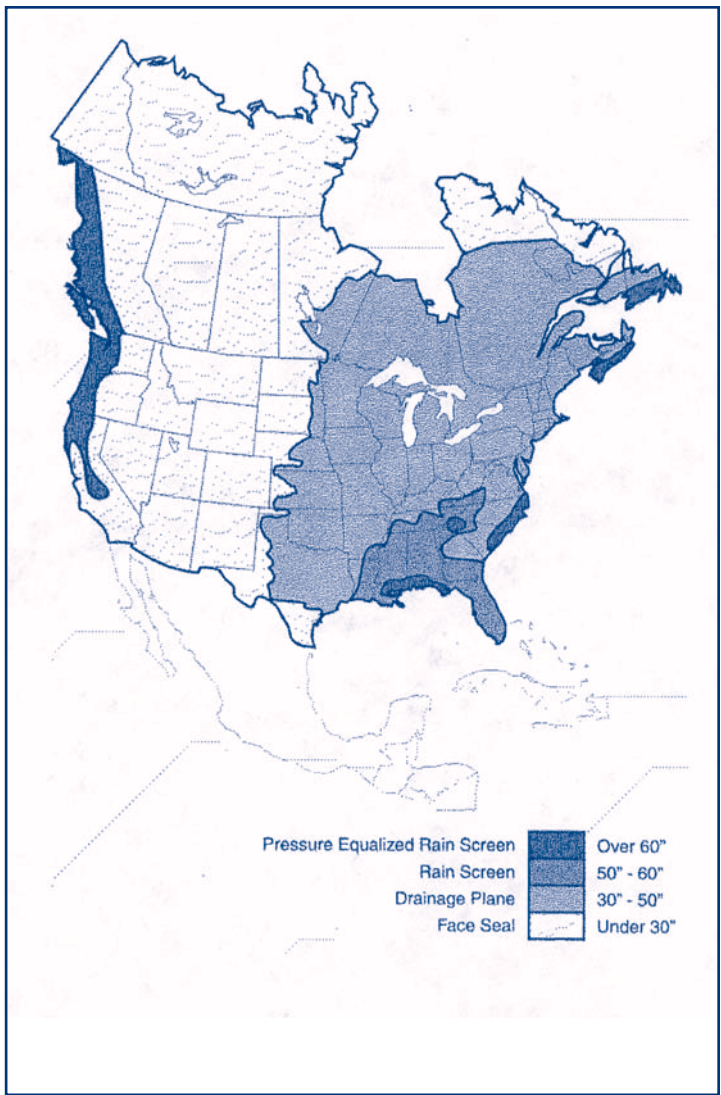

Figure 2: Annual Rainfall Zones<sup>2</sup>

these conditions, vapor diffusion is an important mechanism due to high temperature and vapor gradients. Warm, moist, interior air contains a great deal more moisture than cold, exterior air in winter conditions. This difference creates a strong driving force for vapor to diffuse from the high-concentration interior to the low-concentration exterior through the building envelope. Vapor retarders are essential to control the amount of vapor that migrates into the envelope. See Figure 3.

In hot climates, cooling the interior in summer is a primary design goal. Controlling heat gain from the exterior to the interior by the use of thermal insulation is necessary to control energy costs. Under these conditions, vapor diffusion occurs from exterior to interior for the majority of the year. Hot air can carry much more moisture than typical interior room temperature conditions. Air conditioning increases the driving force by dehumidifying the interior air and increasing the vapor gradient. In hot, humid climates, the vapor diffusion is reversed; vapor barriers are often necessary to prevent diffusion of exterior vapor into a building. In the case of a roof, the membrane or water-tight layer is already a vapor barrier.

In mixed climates, both heating and cooling seasons are important design factors. Thermal insulation is sometimes used to control energy costs but is not essential for either heating

conditions or cooling conditions. Under these conditions, vapor diffusion is not as important due to lower temperature and vapor gradients in winter conditions. In addition, higher summer temperatures and humidities can create significant gradients in the opposite direction, from exterior to interior. Vapor retarders are not usually necessary in the winter and can actually be detrimental during summer, creating a condensation plane and reducing drying capability.

### Vapor Diffusion and Air Leakage

Water in vapor form will move into and through building envelope components by diffusion. But vapor diffusion is a slow process. Significant time must pass before accumulated moisture quantities are sufficient to saturate components in a roof or envelope assembly and appear as liquid water. Air leakage, on the other hand, is a much faster-acting mechanism. See *Figure 4*.

Moisture-laden air moving through a building envelope will deposit moisture on any surface below the dewpoint of the moving air almost indefinitely. As long as the dewpoint of the air remains above the temperature of the surfaces with which it comes in contact, condensation will occur. Whereas vapor diffusion occurs by baby steps, air leakage can "sprint."

For air leakage to occur and create a problem, two things must be true: there must be a hole for the air to flow through; and there must be a driving force or pressure gradient. Holes always exist in building envelopes. It is only the size, number, and location that vary from building to building. The *ASHRAE Handbook - Fundamentals*<sup>4</sup> provides extensive information on air leakage control. Many building codes now specify performance requirements and maximum allowable air leakage rates at prescribed pressure gradients. A tight air barrier makes air leakage control easier but the pressure gradients must also be controlled. A poorly designed or balanced HVAC<sup>5</sup> system can nullify the benefits of a tight air barrier.

However, many designers and builders, especially those covering the mixed and hot climate zones, still do not recognize air leakage as an important issue.

### Economics - Changing Design and Construction

Various factors in the marketplace in the past twenty-five years have created significant changes in the ways buildings are designed and constructed. Numerous new products have been introduced, labor-saving methods and equipment have been adopted, pre-fabrication of components has become commonplace, higher levels of thermal insulation are used, and code and regulatory changes have occurred.

However, many of the traditional "tried and true" methods of design and construction are still in use, although in substantially modified forms. Often this change takes place in small, incremental steps that individually seem unimportant. Eventually a point is reached where the overall design must be evaluated for its suitability to the new design constraints.

Usage changes can have a huge impact on the performance and durability of a structure. A change from seasonal usage to year-round usage can completely reverse the design weather conditions for the building envelope. What worked well for

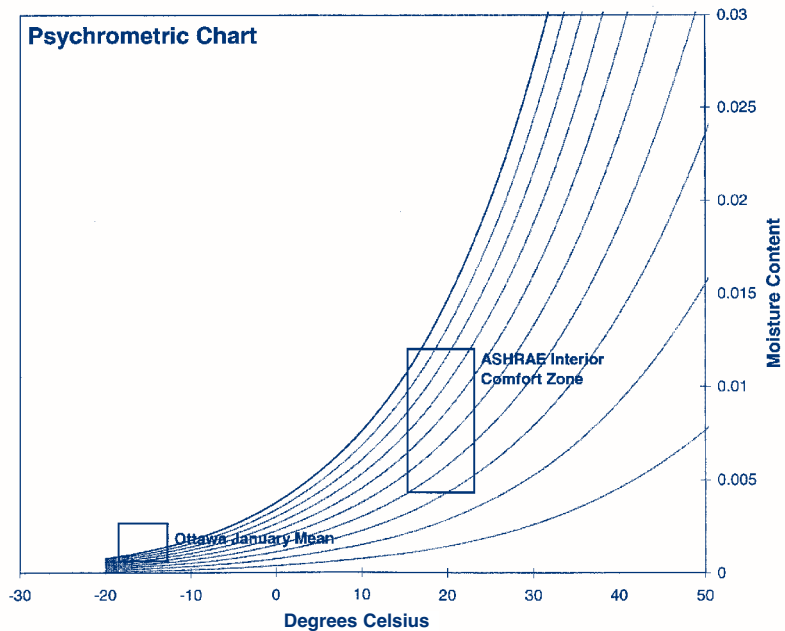

Figure 3: Psychrometric Chart - Ottawa January mean vs. ASHRAE<sup>3</sup> Interior Comfort Zone.

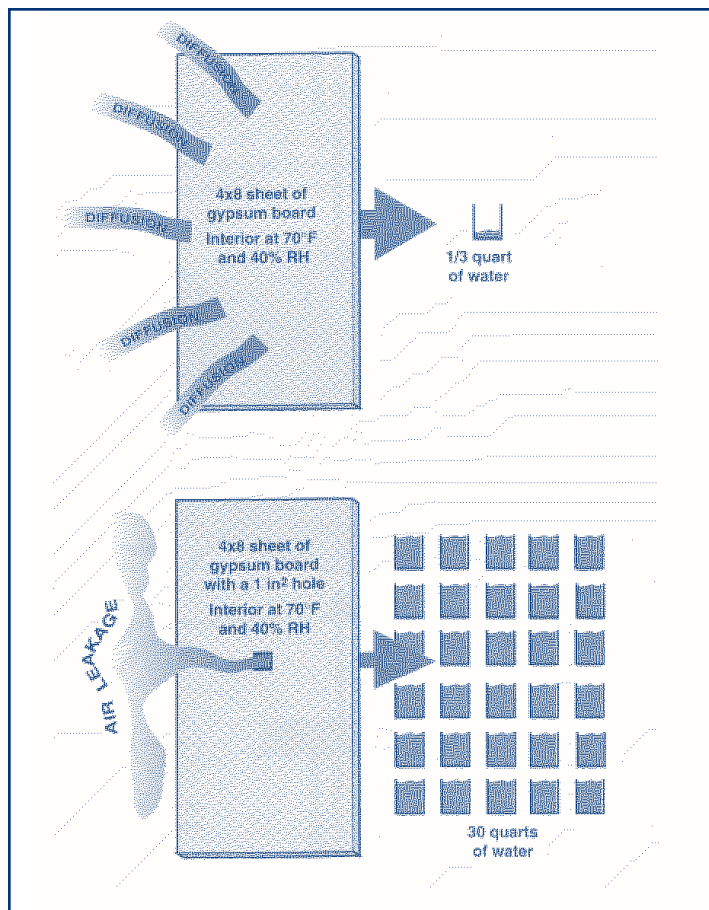

Figure 4: Moisture transport by diffusion versus air leakage.

years can suddenly deteriorate in a matter of months.

Efforts to modernize aging buildings to make them more energy efficient and visually attractive can also be risky. In a hot, humid climate, adding air conditioning to a traditional masonry



RCI, Inc.  
800-828-1902  
[www.rci-online.org](http://www.rci-online.org)

building will significantly change the moisture transmission through the masonry and create condensation surfaces within the wall. In a cold climate, adding insulation to the interior of a traditional masonry building to reduce winter heat loss will make the masonry wall colder, more susceptible to freeze/thaw cycles, and more vulnerable to condensation within the wall. Many times these sorts of renovations become accepted practice even though they are often problematic.

Centralized ownership is also having an effect on building performance. Owners and developers of building portfolios covering different climatic regions tend to retain the biases of their home base. Sometimes a design developed in one area is applied to a large geographical area using a "cookie cutter" approach. A design that works well in a dry, cooling climate should not be expected to perform well in a wet, mixed climate.

### **Architectural - Building Envelope System**

The roof system is not just a barrier to rain penetration but is a part of the overall building envelope which must perform the following functions:

- Keep rain water out.
- Keep water vapor out.
- Let water vapor out if it gets in.
- Keep wind out.
- Keep heat in during the winter.
- Keep heat out during the summer.<sup>7</sup>

A roof that does not perform all of these functions is at risk of causing problems to the overall performance of the building. As the following case studies will illustrate, even water-tight roof systems can still contribute to serious interior water damage.

The reason a roof may not adequately perform a function is often due to poor connections from one trade to another or one element to another. The main field of a roof seldom experiences problems, but the connections from the main field to walls, openings, skylights, etc. often experience problems.

Too often each trade performs its work in isolation. The trade constructing the wall system does not provide access for the roofer to connect to the air barrier of the wall system. Or the roofer installs sheet metal flashings over joints before the sealant installer can caulk them. Some may consider these types of defects to be unimportant because they do not account for a large portion of the building envelope. However, it is often this one percent of the building envelope that accounts for ninety percent of the problems.

By the same token, the mechanical systems designers and installers should have some appreciation for the way in which roofs and walls are constructed. Installers in particular should understand how their work can affect the envelope performance. Exhaust ducts that penetrate the exterior envelope which are poorly sealed to the opening can allow air leakage or dump air directly into the envelope. This reduces the effectiveness of the HVAC system and damages the envelope. Similarly, an HVAC system that creates excessive pressure gradients due to poor balancing or design will significantly reduce the performance of the air and vapor barrier components of the envelope.

As the following case studies will illustrate, even a minor malfunction in a ventilation system can cause serious problems in the building envelope. Alternately, a well designed HVAC system can compensate for minor deficiencies in the building envelope. Similarly, a well designed building envelope can accommodate minor design or operations deficiencies in the HVAC system.

## CASE STUDY # 1, HOCKEY ARENA/ICE RINK

### The Building

The building is an ice hockey arena consisting of four National Hockey League-size (NHL) ice pads, dressing rooms, pro shop, restaurant, bar, and amenities. The layout situates the bar and restaurant space in the middle of the facility with two ice pads to each side with a view of all four rinks from the restaurant area. See *Figure 5*.

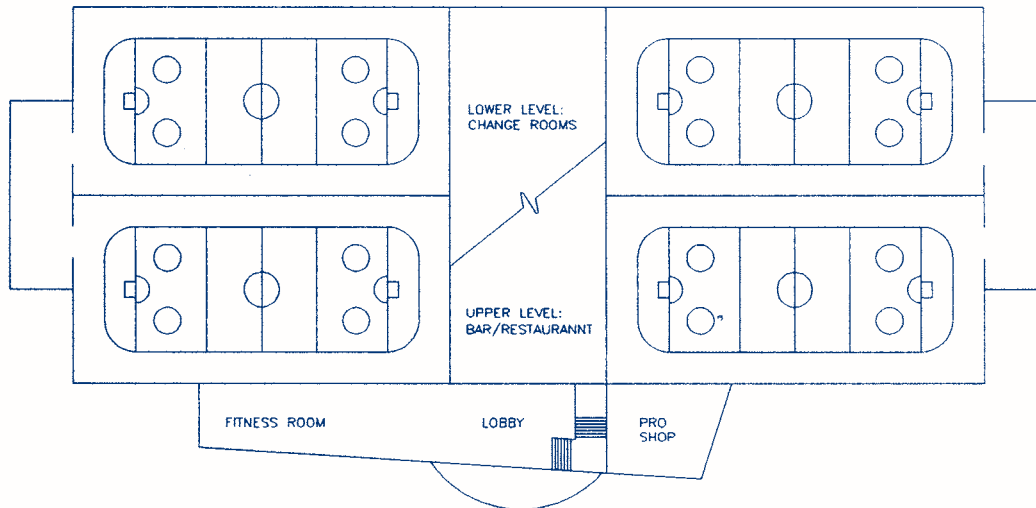

Figure 5: Floor plan of hockey arena.

The basic design was developed by the owners and has been copied in essence to a total of approximately 20 locations across Canada. The structure containing the rink spaces consists of a pre-engineered, steel, rigid frame system. The exterior cladding is pre-painted, corrugated steel on both the walls and the roof, supported on "Z" profile steel purlins.

On both the walls and the ceiling, an interior finish material both supports and conceals the fiberglass batt thermal insulation. The interior ceiling finish consists of a woven polyethylene fabric stretched taut over supporting steel strapping. The polyethylene fabric serves four functions in this system: it is the interior finish (flexible enough to survive puck impacts), it supports the thermal insulation, it is the vapor barrier in the assembly, and it is the air barrier in the assembly.

The interior of the rink spaces is maintained cold and dry by the in-floor ice cooling system and by rooftop air handling units with desiccant-type dehumidifiers.

The air handling units supply and return air to the rink spaces. Air quality sensors control secondary exhaust fans which are "exhaust only" fans to provide rapid air change when combustion pollutants from ice surfacing equipment build up to specified levels.

### Symptoms

Nearly from the beginning, building operations

staff noticed an accumulation of water in the ceiling assembly and water leakage into the rink spaces. The leaks were dripping onto the ice surfaces and melting holes in the playing surfaces. In addition, drips were occurring over the players' benches, generating complaints from the facility's paying customers.

The owners consulted their builders and designers regarding the problems. The builder suggested that water had entered the ceiling during construction and would just need time to dry. The designer agreed that the problem must be due to construction-related moisture because the design and construction had followed tried and true practices and had used high quality materials. The owners were advised to cut some holes in the interior polyethylene ceiling fabric to aid the drying of the assembly.

### The Investigation

Morrison Hershfield Ltd.'s investigation began when the facility was approximately two years old. The building had been experiencing water leakage problems for some time, and the measures suggested by the builder had not been successful in reducing the water in

the ceiling assembly and water leakage into the rink spaces. The firm began by examining the drawings to determine the construction of the ceiling assembly. Very little detail was contained on the drawings with regard to the building envelope design.

Intrusive openings were made to determine the as-built condition of the ceiling assembly. See *Figure 6*. This confirmed the following construction (exterior to interior):

- Sheet metal roofing—supported on 10"-deep steel "Z" purlins.
- Four-inch air cavity (between metal roofing and insulation).
- Six-inch fiberglass batt insulation.
- Woven polyethylene fabric (vapor barrier)—supported on light gauge strapping fastened to purlins.

The insulation layer was found to be saturated in the bottom one-third to one-half of the insulation thickness. The fabric was sagging between support straps under the weight of the retained water. With the exception of the holes intentionally cut in the

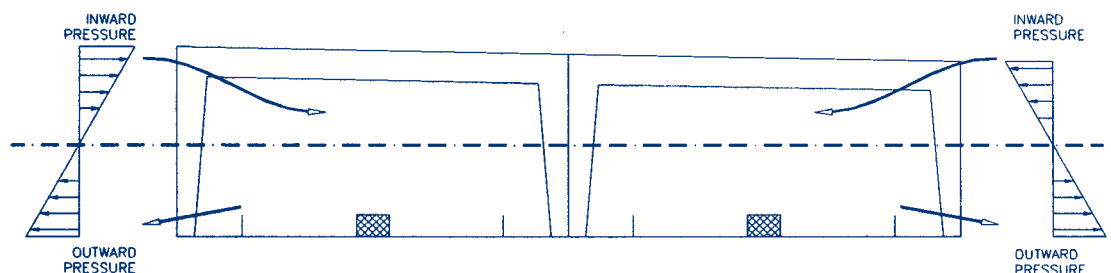

Figure 6: Arena cross section. Infiltration at ceiling due to summer stack effect.

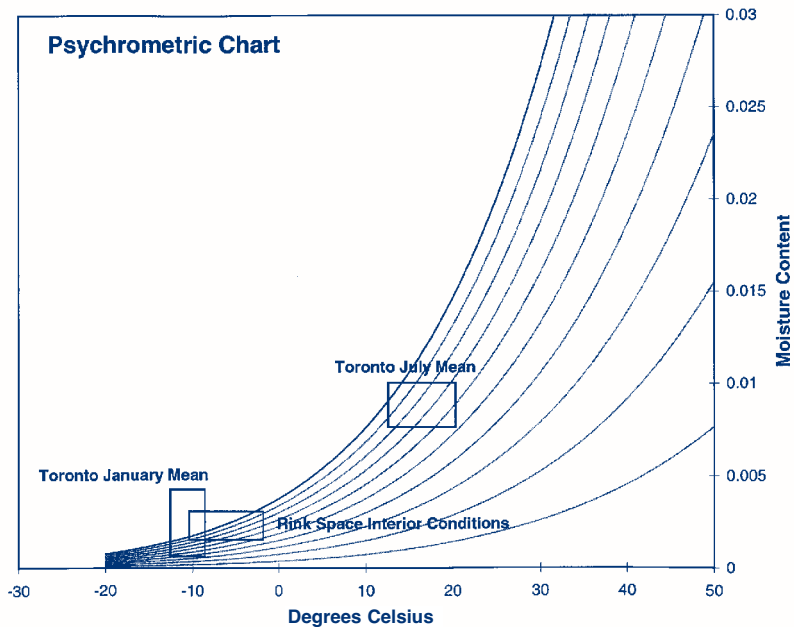

Figure 7: Psychrometric Chart - rink interior vs. exterior winter and summer conditions.

ceiling fabric, the fabric appeared to form a sound air barrier.

The HVAC design and a balancing report prepared by the designer were consulted. The balancing report indicated that each rink is intended to operate at a positive pressure created by a 250 cfm surplus supply from the main air handling unit. The exhaust fans controlled by the air quality sensor remove 5,000 cfm per rink when active.

RCI, Inc.  
800-828-1902  
www.rci-online.org

Pressure measurements were taken under normal conditions and under exhaust fan operating conditions. The pressure readings were 0 Pa (zero Pascals) and -5 Pa (negative five Pascals) respectively. The measured pressure conditions indicate that the rink spaces are operating nominally at a negative internal pressure. This means the majority of the air leakage occurring through the envelope is infiltration.

## Discussion

The ceiling assembly design is a typical cold climate envelope configuration with the vapor barrier to the interior of the insulation layer to satisfy the winter design condition where the interior is warmer and moister than the exterior. However, in the case of an ice rink operated all year round, the dominant design condition is the summer where the exterior is warmer and moister. See Figure 7. This means the vapor barrier is in the wrong position in the envelope for the majority of the year, and, therefore, becomes an unintended condensation plane.

In the traditional arena operating period from mid-September to mid-April, there is a length of time where the interior temperature and dewpoint are higher than the exterior temperature. This suggests the need for a vapor barrier on the interior side of the assembly, and this has become standard practice over time. (See Figure 8). However, the vapor pressures of air at or below freezing are so small that diffusion would not be a concern. Air leakage would be a more important mechanism in moisture transport, in which case the vapor barrier is being bypassed anyway.

The real intention of building arenas with thermal insulation in the exterior envelope is to extend the operating season into the hotter months by reducing heat gain. This clearly indicates that the dominant design condition is vapor drive from exterior to interior during the hotter, more humid months. The traditional arena design no longer holds true when a facility is intended for summer operation.

If the envelope were designed perfectly, the pressure gradients across it would be irrelevant. However, in this case, the incorrect vapor barrier placement is compounded by the negative internal pressure. With the interior operating at a negative pressure, the HVAC system is drawing warm, moist, exterior summer air into the building through unsealed openings in the envelope.

There are always going to be unintentional openings in the envelope, however, the summer conditions of a cold interior and hot exterior produces a natural stack effect which creates the highest pressure gradient at the top of the building. See Figure 6. In addition, the wall-to-roof junction is a common location for envelope defects due to the geometry and the transition between construction trades. Infiltration is more likely to occur at the ceiling than at other locations.

To correct this problem requires one of two things: 1) raise the temperature of the existing vapor barrier above the dew-point of the exterior air, or 2) prevent the moist exterior air from reaching the existing vapor barrier (i.e., the condensing surface of the ceiling assembly).

Option 1 can be accomplished by adding additional insulation to the cold (interior side) of the vapor barrier to increase the temperature of the vapor barrier plane above the dewpoint of the exterior air.

Option 2 can be accomplished in two ways: a) install a vapor barrier on the warm (exterior side) of the insulation; or b) create a large enough positive pressure within the rink spaces that a constant exfiltration leakage will occur through the ceiling, preventing exterior humid air from entering the ceiling cavity.

Both Option 1 and Option 2a require major modification to the existing ceiling system. Adding insulation to the interior surface of the ceiling will be expensive and will require a new interior ceiling finish. Adding a vapor barrier to the exterior side of the insulation will require removal and reinstallation of the metal roofing in order to provide access to the insulation layer. This will also be expensive and disruptive and carries the risk of weather-related damage during the operation.

On the surface, Option 2b, creating a high internal positive pressure, appears to be impractical. Based on estimated overall envelope leakage rates, the necessary positive pressure would require approximately 10,000 cfm per rink of additional supply capacity. This would almost double the capacity of the air handling units. This would essentially mean installing and operating an entire duplicate air handling system for the express purpose of pumping the additional air out through the envelope to the exterior.

Not only does the option carry a high initial cost, but it also carries high operating costs. The advantage of Option 2b is that it requires no modification to the structure and therefore less disruption in building usage.

For each possible solution, cost estimates were generated. The approximate costs are found in Table 1, below.

The magnitude of these cost estimates dictates that other options be explored.

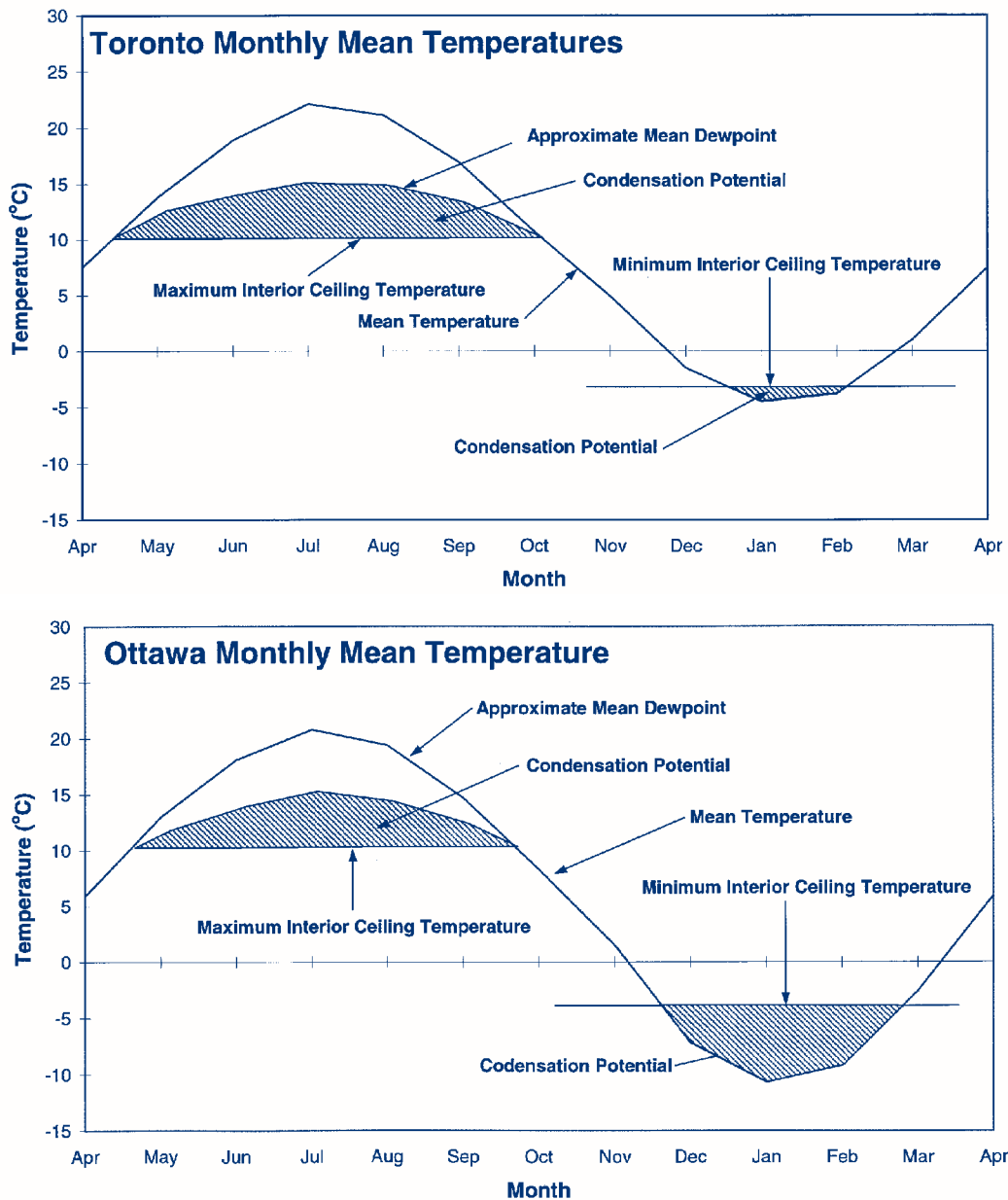

Figure 8: Monthly mean temperatures - condensation potentials.

Option	Description	Cost Per Rink	Total Cost
Option 1	Adding additional insulation below the vapor barrier	\$110,000	\$440,000
Option 2a	Adding a vapor barrier above the insulation	\$150,000	\$600,000
Option 2b	Create positive pressure by adding air handling units	\$100,000	\$400,000

Table 1

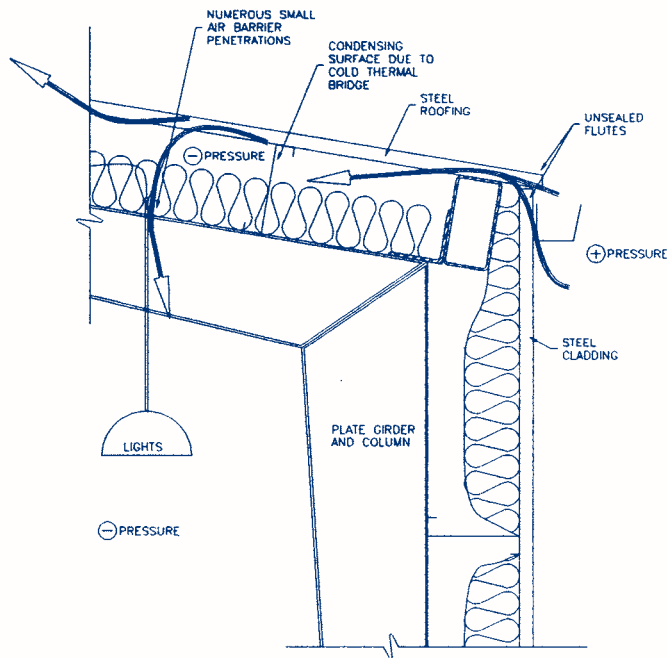

Figure 9: Arena ceiling assembly schematic—existing conditions—infiltration.

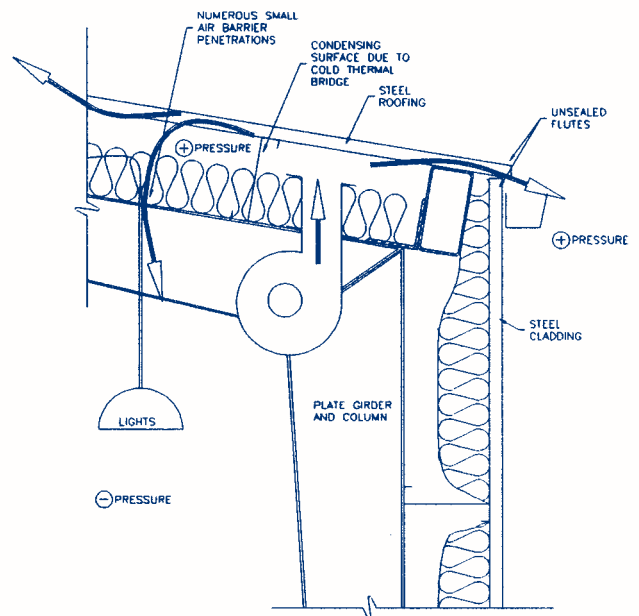

Figure 10: Arena ceiling assembly schematic—proposed conditions—exfiltration.

## The Solution

Of the possible solutions listed above, the pressurization approach appears to have the most potential due to the fact that it requires no modification to the ceiling structure. Alternative means of creating a positive pressure across the plane of the ceiling assembly were examined.

One alternative considered was to pressurize the ceiling cavity only. The overall interior space conditioning would continue to function the same. The positive pressure in the ceiling cavity must be produced by supplying cold, dry, conditioned interior air into the space. Supplying exterior, hot, humid air would only worsen the infiltration problems by filling the cavity with moist air. By pressurizing the ceiling cavity with rink space air, any leakage back into the rink would not create problems.

One system considered was to redirect the exhaust fans in each rink to blow out through the ceiling space rather than directly to the exterior. This would accomplish two things: the exhaust fans would not contribute to the depressurization of the interior each time they were triggered, and the ceiling cavity would be supplied with cold, dry, interior air to displace the exterior air.

Upon closer examination, the basic concept was found to be sound; however, some shortcomings were identified. The existing exhaust fans would supply a high volume at a single point in the ceiling. This would result in non-uniform pressure and non-uniform flow throughout the ceiling cavity, with areas of the

ceiling cavity receiving no benefit. This indicates that the air should be supplied at multiple locations, each one providing a small flow volume. See Figures 9 and 10. A basic configuration of five fans per rink was considered. The system was assumed to have variable speed fan motors and associated controls so that the minimum required flow would be provided to the ceiling cavity under normal conditions. The total flow capacity of the fans was assumed equal to the existing exhaust fans controlled by the air quality sensor so that the new fans could assume the same function.

Cost estimates were generated for the multiple small volume fan scenario. They are shown in Table 2, below.

The capital cost of this scenario is only between five and ten percent of the next lowest cost option. In addition, this scenario will not increase operating costs. Because the existing exhaust fans are being substituted with the new fans, approximately the same volume of air will be exhausted, but now the outlet location will change.

The targeted pressurization solution is currently being implemented in the facility. Moisture sensors will be installed at several points in the ceiling system to confirm that the system is drying out and to detect remaining pockets of wet insulation that may require balancing adjustments.

Several of the issues outlined in the factors affecting building performance contributed to the arena problems. The change from seasonal to year-around usage changed the dominant design condition for the envelope, but the traditional design was

Option	Description	Cost Per Rink	Total Cost
Targeted	Substitute multiple small volume fans for the existing exhaust fans	\$5,000	\$20,000
Pressurization		\$10,000	\$40,000

Table 2

used. The “cookie cutter” design developed by the centralized ownership was not well suited to the location where it was constructed. The ceiling fabric material chosen for this application is an excellent product that serves several functions at once for a typical cold climate envelope, but it was poorly suited to this application. And finally, poor maintenance of the air handling units prevented the HVAC system from functioning correctly and created excessive negative interior pressure, making a bad situation even worse.

The investigation of the arena problem could have ended with the discovery of the faulty envelope design. The solution could have begun and ended with the \$400,000 repair to address the obvious problems. However, by considering how the function of one element of the building affects another, an elegant and inexpensive solution was found to overcome poor envelope design, less than ideal HVAC design, and poor HVAC maintenance. The resulting solution was less expensive to build, less expensive to operate, and less disruptive to normal facility operations than the more conventional repair options.

The following examples demonstrate how this information can be applied to other common buildings.

### Example # 1, Air Conditioned High Rise

On the surface, an ice hockey arena in Toronto and a high rise office building in Houston, Texas, or Savannah, Georgia, do not seem to have much in common. Toronto is in a cold climate and Houston and Savannah are in hot, humid climates. See Figure 1.

The similarity comes from the difference in the normal building interior environment and that of the predominant exterior environment. See Figure 11. Both the arena and the high-rise office tower are maintained at temperatures that are cooler than the exterior. More importantly, the building interior is significantly below the dewpoint of the exterior air. For example, Houston averages more than 90 days per year above 90°F (32°C) and has a consistently high humidity due to its proximity to the ocean. This results in extremely high exterior dewpoints.

The predominant stack effect is infiltration at the top of the building and exfiltration at the bottom of the building. Stack effect occurs due to the different densities of hot and cold air. The magnitude of the stack effect pressure is proportional to the temperature difference and the vertical distance away from the neutral pressure plane. In the case of a high rise office building, the large vertical dimensions accentuate the stack effect produced by relatively small temperature differences.

Consider a 40-story building in Houston in July. The exterior temperature is 95°F (35°C), and the relative humidity is 75%. This results in an exterior dewpoint of 86°F (30°C). The interior conditions are at the upper boundary of the ASHRAE comfort zone, with temperature at 73°F (23°C) and the relative humidity at 70%.

The resulting stack effect pressure across the exterior wall at the top floor is approximately 29 Pa from exterior to interior.

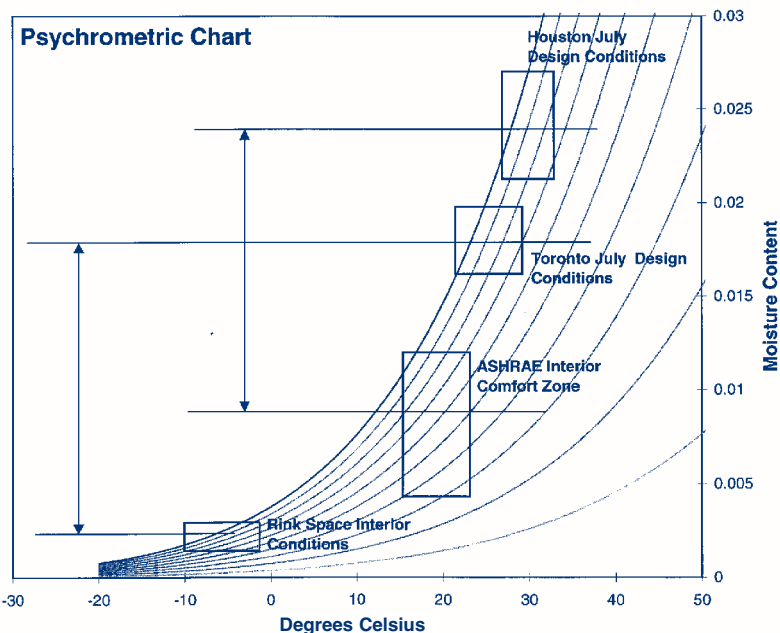

Figure 11: Psychrometric chart - rink vs. Toronto summer and office vs. Houston summer.

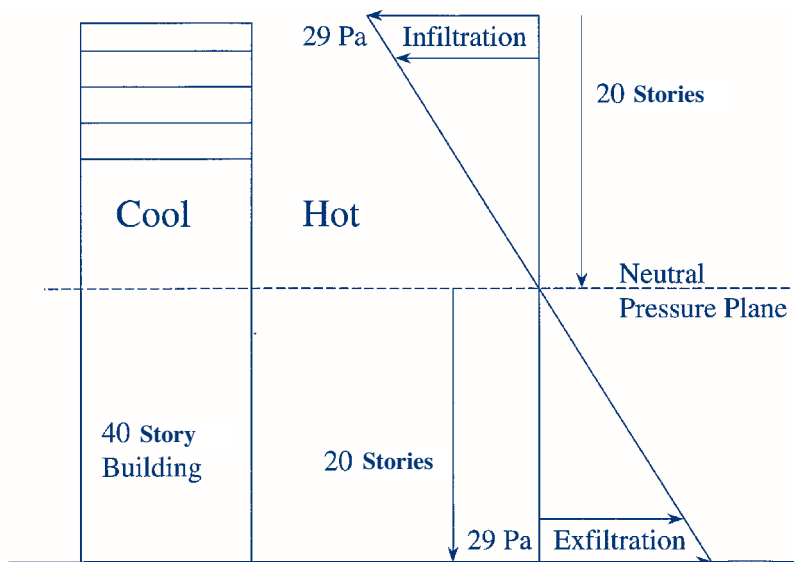

Figure 12: High rise structure with infiltration caused by stack effect.

See Figure 12. Without mechanical pressurization of the interior to counteract the stack effect, the warmer, moister, exterior air will leak into the envelope of the upper portion of the walls and roof. Once the air moves into the envelope, it quickly comes into contact with surfaces below its dewpoint, and the moisture it is carrying is deposited as condensation.

One of the condensation surfaces the air is likely to come in contact with is the air supply ducting in the ceiling space. See Figure 13. Under heavy cooling loads, as in this scenario, the air is usually supplied at approximately 55°F (13°C) and allowed to mix with the warmer air in the occupied space. These cold duct surfaces, even when contained within the conditioned space, are perfect condensation surfaces for infiltrating air. Even surfaces within the occupied spaces such as furniture and equipment

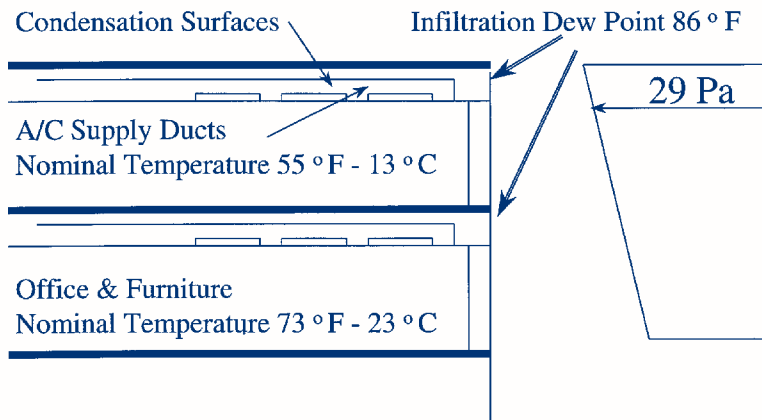

Figure 13: Upper floors of high rise structure infiltration and condensation points.

which will be near the ambient internal temperature of 73°F (23°C) are potential condensation surfaces, although most of the excess moisture is likely to be condensed on other surfaces before reaching them.

In keeping with the title of this paper, the most noticeable symptom is likely to be water dripping from the ceiling. On the top floor this can easily be misdiagnosed as a roof problem. Or it may be considered a balancing problem with the HVAC supply.

The real cause of these symptoms is air leakage through the exterior envelope. Even with a correctly designed envelope, these problems can occur due to defects in the construction of the air barrier system. For example, if the air barrier is not continuous at the wall-to-roof junction, then leakage can occur. There are two ways to stop this: plug the holes or remove the pressure gradient.

Although providing the tightest envelope possible has many advantages, even well-installed air barriers have some minor defects. Therefore, plugging all of the holes in the envelope is impractical. The safe choice is to maintain a positive pressure large enough to counteract the natural stack effect. This will improve the performance of the exterior envelope by reducing the time periods when the building operates under potentially

damaging pressure conditions. These conditions would then be limited to wind effects.

### Example # 2, Historic Masonry Building

One of the forces driving the changing design and construction of buildings is the economic need to modernize aging buildings to keep them competitive in the rental market. This often means replacing interior finishes, installing modern heating, air conditioning, and communications systems. However, the modernization seldom includes building envelope upgrades.

Consider a 4-story building in Savannah, GA, in July. The exterior temperature is 90°F (32°C), and the relative humidity is 90%. This results in an exterior dewpoint of 86°F (30°C). The interior conditions are at the upper boundary of the ASHRAE comfort zone, with temperature at 73°F (23°C) and the relative humidity at 70%.

The resulting stack effect pressure across the exterior wall at the top floor is only approximately 3 Pa from exterior to interior (see Figure 14). However, the new air conditioning system often adds to this pressure gradient unintentionally. In a renovation scenario, the locations where new ductwork can be installed are limited. This often results in supply ductwork being installed in the attic space and the air handler being installed in a service room somewhere within the conditioned space. Because the air handler draws the makeup air from the conditioned space, any leaks in the supply ducts in the attic will result in a depressurization of the conditioned space. See Figure 15.

The results are similar to both the high rise scenario and the arena scenario in that the high dewpoint exterior air leaks into the upper floors and attic space and condenses on the cooler interior surfaces, the cool ductwork, or accumulates in the ceiling materials.

The other mechanism of deterioration is caused by the vapor gradient created across the exterior due to the cooled and dehumidified interior. Without a vapor barrier in the envelope, the different interior environment creates a vapor flow from exterior to interior. As the moisture moves through the masonry, it dis-

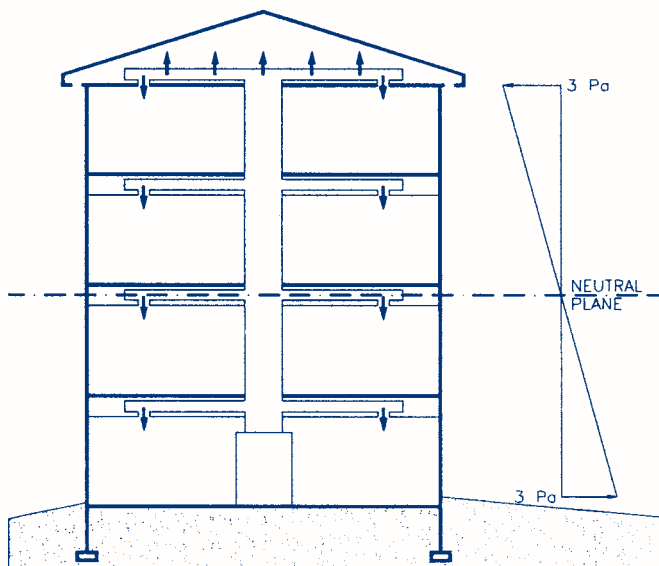

Figure 14: Low rise structure with infiltration caused by stack effect.

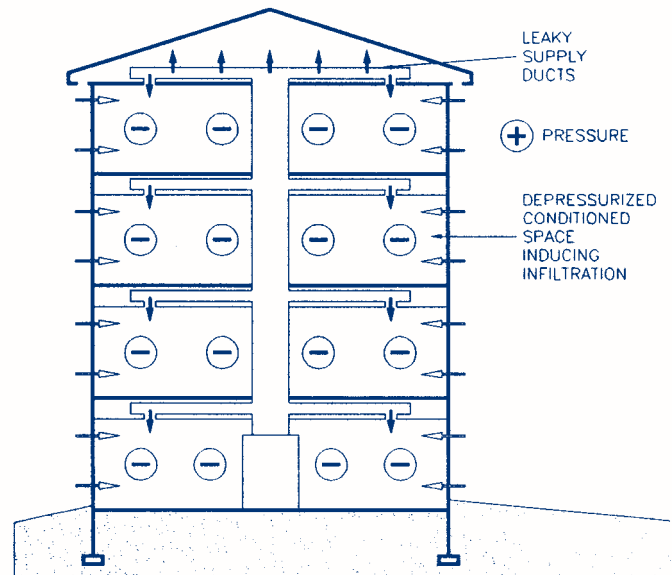

Figure 15: Low rise structure with infiltration caused by ductwork leakage.

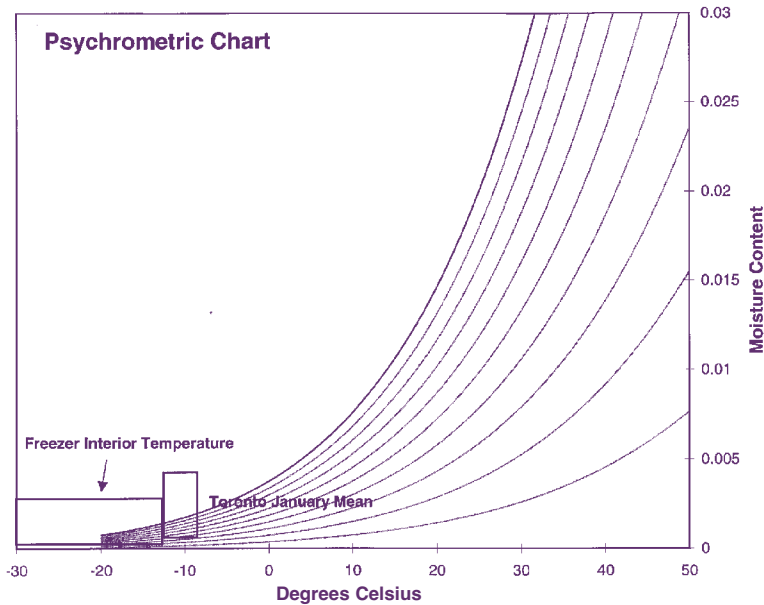

Figure 16: Psychrometric chart - freezer interior vs. Toronto winter.

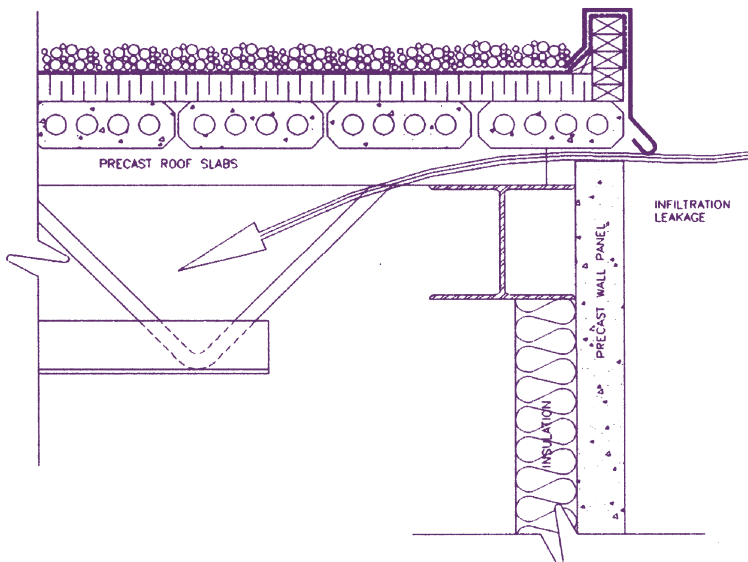

Figure 17: Freezer roof structure schematic showing infiltration caused by stack effect.

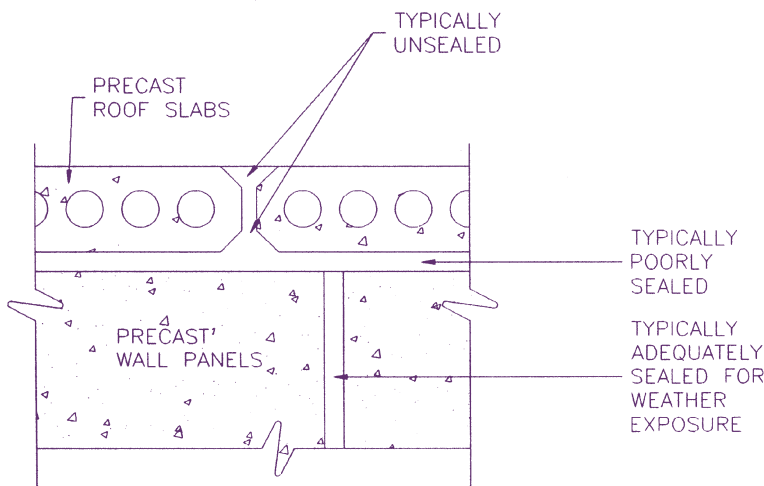

Figure 18: Freezer roof structure detail showing infiltration points.

solves and transports salts. When the water evaporates from the interior surface of the masonry, the salt leaves solution and it is deposited on the surface as a powder, creating efflorescence. The efflorescence is a symptom of slow deterioration taking place in the masonry due to the loss of minerals from the mortar and masonry units.

In this example, air leakage through the exterior envelope is still the cause of the problems, but the driving force for the leakage is different. The combination of the leaky supply ductwork and the return air drawn only from the conditioned space create a negative interior pressure and an air flow from humid exterior to dry interior. The preferred flow direction would be from dry to humid because dry air leaking out of the building would absorb moisture as it passes through the envelope rather than depositing moisture. The risk associated with the air leakage is much less in this case.

### Example # 3, Freezer Building

The case of a freezer building is very similar to that of the arena case study. The interior is colder than the exterior for nearly all of the year depending upon the building's location. See Figure 16.

The predominant stack effect is infiltration at the top of the building and exfiltration at the bottom of the building. Without mechanical pressurization of the interior to counteract the stack effect, the warmer, moister exterior air will leak into the envelope of the upper portion of the walls and roof. Once the air moves into the envelope, it quickly comes into contact with surfaces below its dewpoint, and the moisture it is carrying is deposited as condensation.

Precast concrete panels are a common form of construction for this type of building. See Figure 17. The joints between panels are seldom sealed as well as they should be, especially where they are not directly exposed to the exterior. See Figure 18.

Regardless of the design or quality of construction of the envelope, maintaining a positive pressure large enough to counteract the natural stack effect will improve the performance of the exterior envelope.

### Example # 4, Swimming Pool

The case of a swimming pool building is slightly different than the previous examples and is included here as a cautionary example. The other examples illustrate the advantages of creating a pressure drive in the direction of cold to warm or dry to humid. The rationale is that the dry air entering a humid space will absorb moisture without causing damage, whereas moist air entering a cold, dry space will dissipate moisture and cause condensation.

This is advantageous as long as the flow volumes remain small. In the case of a pool enclosure operating at a high interior temperature and relative humidity, the inward flow of cold air can cause serious problems.

In all but the extremely hot and humid climates, the air inside a pool enclosure will be at a higher dewpoint than the exterior for nearly all of the year. See Figure 19.

A well-constructed exterior envelope will have a number of small, scattered defects, each of which will allow only a small flow of air leakage. The air leaking in is warmed and absorbs moisture. However, when this volume increases enough, even in a single, localized area, the colder exterior air leaking in cools the surfaces it contacts. Because the interior dewpoint is high, even a small degree of cooling can lower the surfaces below the dewpoint.

If the infiltration occurs into a suspended ceiling space as in the earlier example, the ceiling materials will be cooled from above, creating potential condensation surfaces. See *Figure 20*. The space above the ceiling will not be as susceptible to condensation forming because the cold air will tend to dry the air within the space by absorbing moisture from the air already in the space. However, the drier air above the ceiling will create a vapor gradient across the ceiling, further increasing the absorption of moisture into the ceiling materials. In one extreme case that the author investigated, the ceiling materials became so saturated with water that they lost their integrity at fastening points, and the ceiling collapsed.

But pressurizing the pool interior to avoid this potential is not a viable option. Because of the extremely high vapor content of the air in a pool building, exfiltration will deposit large amounts of water into the exterior envelope. In one extreme case that was investigated by the author's firm, prolonged exfiltration leakage into a steel-sided pool facility formed a mass of ice on the interior of the steel siding large enough to deform the siding and severely damage the other envelope materials.

In the case of a swimming pool enclosure there really is no substitute for a well constructed air barrier in the exterior envelope. In fact, all of the examples depicted require a relatively functional air barrier to be successful. Creating small air pressure gradients in the correct direction can help relieve moisture problems caused by small air barrier defects. However, pressurization is unlikely to be successful in controlling problems caused by large defects, and the outward leakage of the extremely humid pool air can be highly damaging to the envelope by depositing large amounts of moisture.

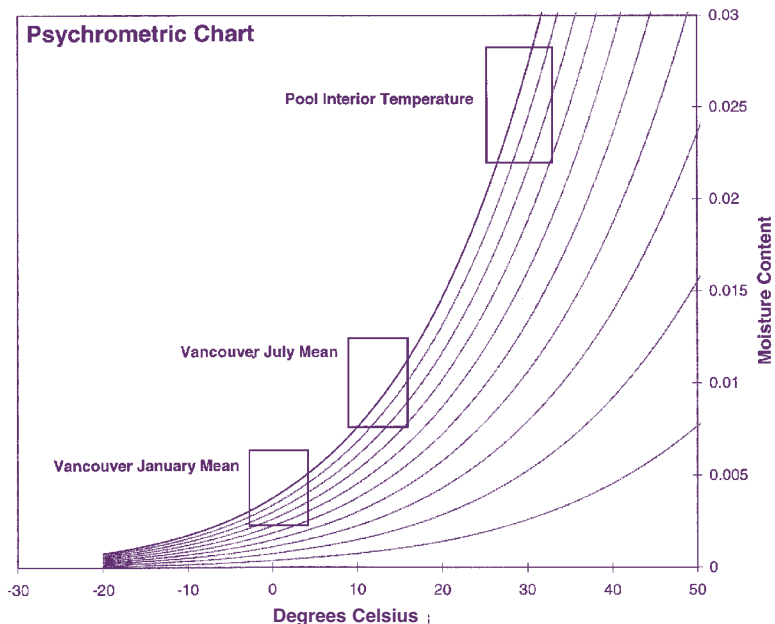

*Figure 19: Psychrometric chart - pool interior vs. Vancouver summer.*

## Closing

The above case study presented a unique solution to a unique problem, and the accompanying examples have illustrated how this solution can be applied to more common situations. However, the underlying lesson of these illustrations is to think of the building as a complete system and to examine how some of the traditional assumptions may have changed.

By considering how the function of one element of the building affects another, an elegant and inexpensive solution may be found. Too often each specialty thinks of its work in isolation. But the HVAC system will never function correctly if the air barrier is excessively leaky because the variable leakage caused by wind effects will make a stable flow balancing impossible. Similarly, the building envelope will not provide the intended thermal insulating value or expected lifespan and durability if the HVAC system creates excessive pressure gradients which drive air through the envelope, depositing moisture as it goes.



RCI, Inc.  
800-828-1902  
www.rci-online.org

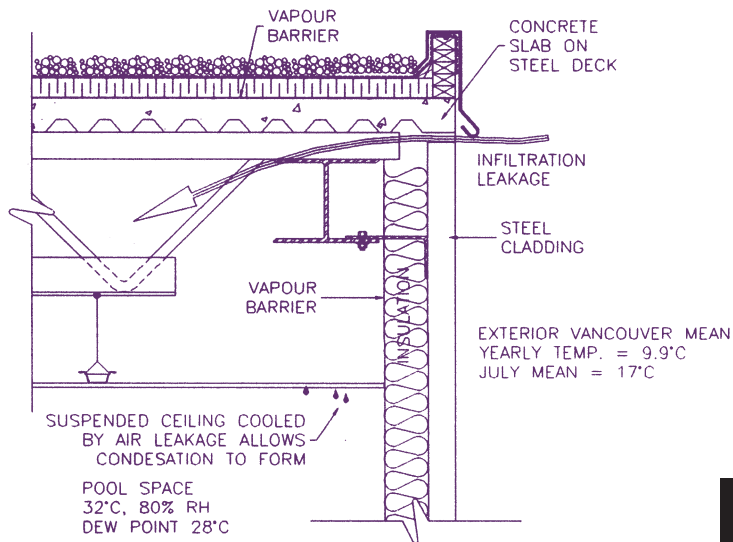

Figure 20: Pool roof structure schematic.

This is not just an issue of importance to design and construction professionals. The building owners will ultimately pay higher than necessary operating costs, dealing with occupant complaints with buildings that are too hot in one area and too cold in another, drafty in one area and stuffy in another. Or perhaps the complaints will be due to an annoying water leak that comes and goes but never gets resolved. Just the sort of thing to make a tenant look for alternative space in someone else's building. ■

*This paper was originally presented at the RCI Convention in Charlotte, NC in 1999.*

## FOOTNOTES

1. Lstiburek, Joseph, *Builder's Guide - Mixed Climates*, Building Science Corporation, 1997.
2. Ibid.
3. *ASHRAE Handbook Fundamentals, SI Edition*, American Association of Heating Refrigeration, and Air Conditioning Engineers, Inc., Atlanta, Georgia, 1989.
4. Ibid.
5. HVAC System - Heating, Ventilating, and Air Conditioning system.
6. Lstiburek.
7. Lstiburek.
8. Lstiburek.
9. Compton's Encyclopedia, 1999.

## ABOUT THE AUTHOR

**Steve Murray** is a Senior Project Manager with the Building Engineering and Management Group of Morrison Hershfield Limited's Toronto office. He is a member of the Professional Engineers Ontario and of RCI and is on the Education Committee of Region 8. Steve is experienced in infrared thermography. The main case study in this paper involves a hockey arena facility. Having played hockey from the age of four, this project forms a unique connection between the author's work and play.



**STEVEN MURRAY**