

# Early Leak Detection Capabilities —

## More Timely Than Ever

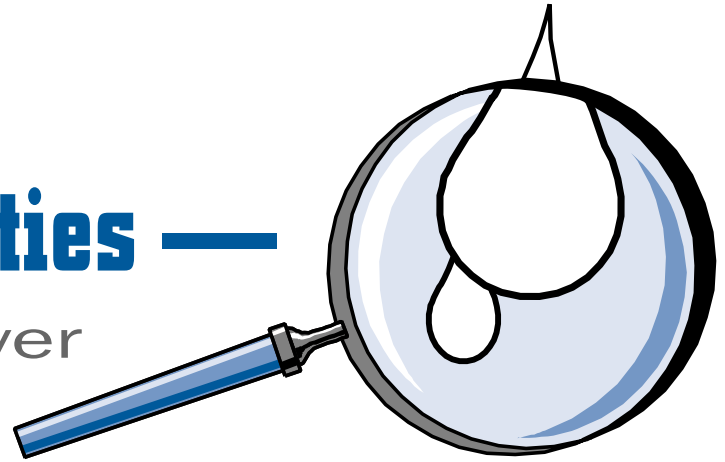

BY JAMES P. SHEAHAN, RRC, FRCI

### Introduction

Imagine that the perfect roof is about to be built. It will consist of a heavy gauge metal deck, an air barrier, a layer for a fire barrier, tapered insulation, a cover board, a multi-ply membrane held together with mechanical fasteners, and, finally, a course of concrete pavers. If not perfect, it appears to be impregnable. However, what it really is is the Titanic of roofing—the unsinkable ship, the unleakable roof.

Water is insidious and pervasive in finding ways to enter into roofing systems. Water may be built in or it may enter through omissions, damage, unprotected projections, alterations, etc. No matter how much effort and thought go into making a roof waterproof, there should be a safety valve built into the system to allow the water to be discovered and eliminated in a timely fashion. This is not only to protect the interior of the building but to protect the roof assembly from undetected degradation. It is becoming more and more difficult to find leaks soon after they occur. The types of roofs being built today make it impossible to find leaks before damage has been done to the roofing system. This is mostly due to the fact that multi water barriers are built into roofing systems to solve other problems ranging from fire resistance to wind resistance to water resistance. While the odds of having leaks in these roofs are low, the odds of finding leaks is even lower.

Certain roofing systems lend themselves to finding leaks, thereby eliminating potential long-term degradation problems. These roofing systems do not make up a major portion of the market. Examples are: lightweight insulating concrete decks over vented metal, poured gypsum decks, wood plank decks, and panelized concrete deck systems. *Exhibit 1* depicts the types of roofs popular today and becoming more popular with the demands for better performance of roofing systems. Poured concrete decks, being monolithic, provide a barrier to the passage of water to the interior. When water does pass through, it is not related to the point of water entry, complicating leak location until copious amounts of water have entered the roof system

and created problems by degrading the roofing components. Metal decks with a barrier directly above, either designed to be an air barrier or a vapor retarder, develop the same condition as the concrete deck.

Green roof systems are now becoming popular in the U.S. These involve a form of protected membrane roof that may only have one barrier to the passage of water, but have a significant barrier on the top of the roof making it difficult to view the roofing membrane for its integrity.

*Exhibit 1* also provides an estimate of the percentage of roofs that have multi barriers. All together, they represent one third of the new and reroof markets. Recover roofs, which by definition are two membrane roofs, represent approximately one-third of roofs. The new and reroof projects account for three-fourths of the market; therefore, one-third of these means one-fourth have multi barriers. All of the recover roofs have multi barriers, representing another one fourth, so in total, the roofs with multi barriers (which defy not only early detection but localization of leaks), represent one half of the roofing market. There is no intention to suggest these numbers are absolute, but they illustrate the order of magnitude of multi-barrier roofs.

This portion of the market appears to be growing with the increased interest in Green roofs and the re-cover roofing

Estimation of Roof Systems With Multi Barriers			
Type Roof	% Market	Barrier Type & %	% Multi Barrier
Concrete Deck	20	Barrier 100%	20
Metal Deck	50	Vapor Retarder 10%	5
Metal Deck	50	Air Barrier 10%	5
Other Decks	30	No Barrier 0%	0
Green & PMR <sup>1</sup>	5	Top Covering 100%	5
Recover	30	Two Membranes 100%	30
1. Protected Membrane Roofs			

*Exhibit 1*

Provide Sustainable Roofs By:	
Intelligent combination of materials, design, and construction	20 years
Use of timely and proper maintenance	+ 10 years
Employing new systems—cool roofs, green roofs, etc.	25+ years
Re-coverable roofs—double life	40+ years

Exhibit 2

approaches. The entire market is influenced by the demand to make roofs more sustainable for economic and environmental reasons. Exhibit 2 illustrates approaches used to varying degrees to extend the useful lives of roofing systems. Suggested life spans and extensions of useful lives can be used in combination. For these greatly extended time frames to be realized by resisting degradation due to fire, wind, water, and weather, early leak detection and localization methods need to be incorporated to verify the roof conditions to keep them sustainable.

The days of walking a roof are numbered, and present-day non-destructive survey methods need to be updated. The need for new approaches to detect and pinpoint leaks soon after they occur is becoming clearly obvious. Technology is available. The economics are favorable. The reluctance to discuss and admit that good roofs can leak should be dismissed. There is opportunity here. If a good roof is a roof that won't leak, I have never seen a good roof. A roof where a leak is regarded as a nuisance, not a major problem, can be a good roof.

Those responsible for finding and repairing leaks vary over the life of a roofing system. The first year or two, contractors often have the obligation to handle leaks. The problem is knowing when the leak occurred. The owner of the building is the first to know that a leak has occurred in the building; however, it may have penetrated the waterproofing layer long before it entered the building. This problem is exacerbated based on how many barriers are built into the roofing system. The repair of the leak once it is found seldom includes removing any of the other roofing components that may be damaged. In most cases, the leak is due to an omission early on, and severe damage to the roofing system is the exception rather than the rule in the first year or two.

The time frame from the second to the tenth or fifteenth years represents the term of a warranty. The manufacturer normally is involved in responding to notification of leaks. Again, the signal that there is a leak is a complaint from the owner who observes water entering the building. Now the time frame that water could exist in the roofing system has been greatly

increased, and the chances of degradation to the roofing components are increased. Again, in most cases, the fix is to remedy the leak, not to repair the system.

After the warranty has expired, the responsibility of handling leaks is up to the owner. Again, the owner is the one who notes when a leak occurs and most likely will call for professional assis-

tance in repairing the leak. But he will be responsible for the cost of the repair, and often the fix will relate only to repair of the leak, not of the roofing system, because the cost of total repair (even if it can be repaired) is high.

The owner cannot be considered an effective early warning system. He can be vocal, insistent, and in some instances, accurate with respect to when and where the leak occurs. The implementation of preventive maintenance and non-destructive surveys can assist in providing an

"earlier" versus an "early" warning system. A cost is involved. Unfortunately, the industry has not been successful in convincing most owners that this is a method to protect their investment. This is partially due to the fact that roofing systems are over-sold with respect to their capabilities, and very often the warranty aspect is not correctly understood by the owner.

The next step that follows when there are leaks that cause substantial damage is recognizing the cost for adequate repairs is very high. The repairs can involve reroofing which could result in a total tear-off or recover of the existing roofing system. These costs are definitely high and can lead to expensive litigation.

If all systems were of the type that leak observance was quick and location was timely, then secondary problems to the roofing system would be minimized. Downtime and damage to the interior would be minimal. With one half of the roofing systems being built today, this is not the case. A mechanism is needed to provide timely leak detection and localization.

### Present Techniques for Leak Detection

One of the best leak detection systems is based on experience and common sense. Individuals with experience in the roofing industry know how the components are interconnected and can make a good judgment based on viewing the point of entry of water into the building. Then, by examining the roof surface, they can identify the most likely point of entry, be it a projection, some position up slope, a portion of roofing which tends to be submerged due to ponding, etc. This method is useful for finding leaks in roof systems which are performing. The roofs which are failing due to splitting, tearing, ripping, etc. would fall outside of leak detection and be considered as candidates for re-roofing.

Another method which should be used with caution is flood testing. Flood testing is a method that can be used to separate various components such as walls, parapets, and projections from the roof system by specifically wetting down these areas in a logical sequence. Flooding the roof membrane in total is

dangerous in that if it does leak, a great amount of water will enter the roofing system before it enters the building where the first knowledge of that leak is observed. Water testing is the most effective when there is confidence that the roofing system itself is not the source of leakage. It is a mechanism in which the

*Ours may be the only major industry without early warning systems.*

area surrounding the roof such as the walls and parapets can be isolated and tested to locate the point of water entry.

The most popular methods for leak detection are the non-destructive mechanisms that are primarily based on infrared, capacitance, and nuclear technologies. It should be noted these systems rely on some form of degradation to the roofing system (primarily the insulation) by water ingress. These systems are effective in locating the total areas that are wetted. They are not particularly adept at locating the points of water entry. That goes back to experience and deductive reasoning. If these surveys are performed periodically, they can detect the early presence of a leak by noting small areas of degradation to the roofing system. While they could be considered "earlier" leak detection systems, they are not early leak detection systems except by coincidence.

### Review of the Technical Literature With Respect to Leak Detection

The following is not intended to be an exhaustive list of all the leak detection methods but rather a reasonably representative list of systems developed not only in the roofing industry but in other industries. These systems can be adapted to the roofing industry. Essentially, none of these systems has been well accepted or well developed for the roofing industry. Noting the dates of some of these systems, it can be seen they have been around for a relatively long period of time yet not successfully adapted to the roofing industry.

### ASTM D-4545 (86)

This is a standard practice for determining the integrity of factory seams used in joining manufactured flexible sheet geomembranes. Among other testing procedures, it describes three non-destructive test methods for checking seams for integrity. These methods (air lance, vacuum box, and ultrasonic

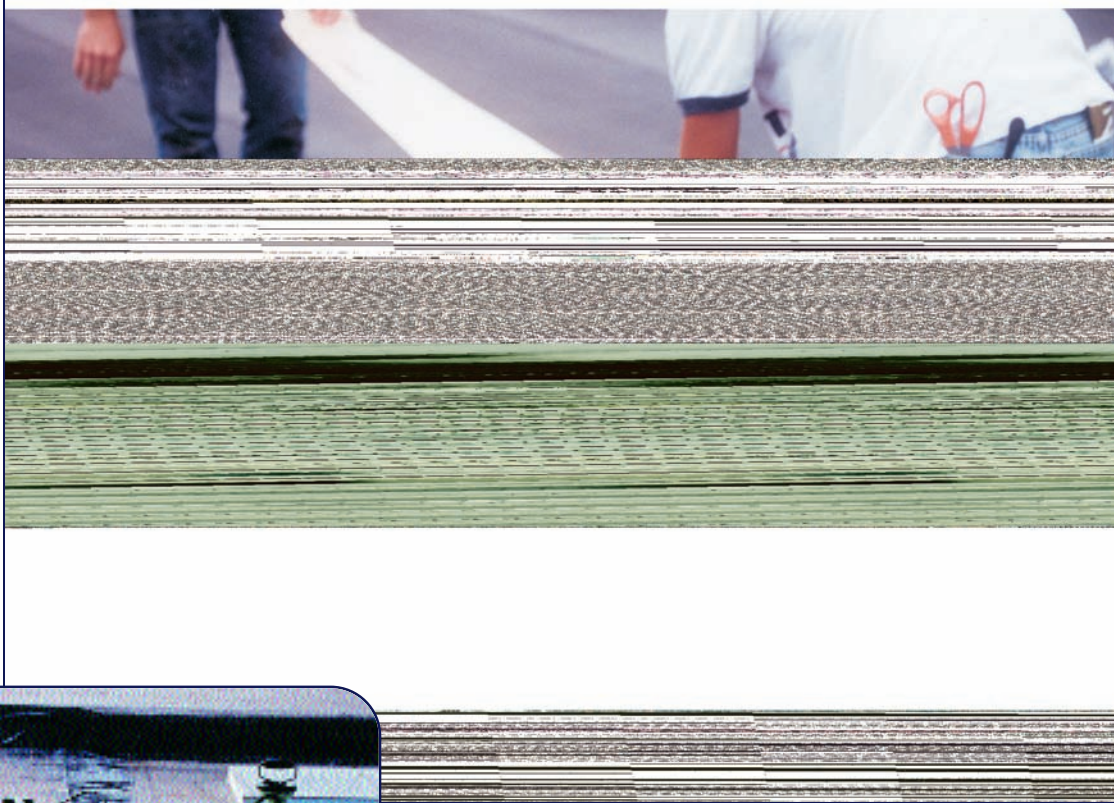

Above: Exhibit 3: Application of seam cover with bond breaker at center line develops a void to accommodate pressurizing the opening in order to test continuity and quality of seam bond.



Left: Exhibit 4: View of pressurized seam using portable compressor. Water/soap solution used to locate leaks if present. Uniform profile of pressurized seam denotes correct adhesion area.



Above: Exhibit 5: Example of seam with poor adhesion as noted by non-uniform cross section of pressurized seam. Pressure set to a value below peel strength of seam desired.

Exhibit 7 (right): The inflated area of a roof membrane being checked for leaks is traversed using a sensor to detect escaping gas or by spraying a water-soap solution to detect bubbles from a hole in the membrane.

Exhibit 6 (below): Blower adapted to a roof vent to apply a low pressure below membrane to inflate an area of 100 squares or more. A tracer gas may be mixed with the air.

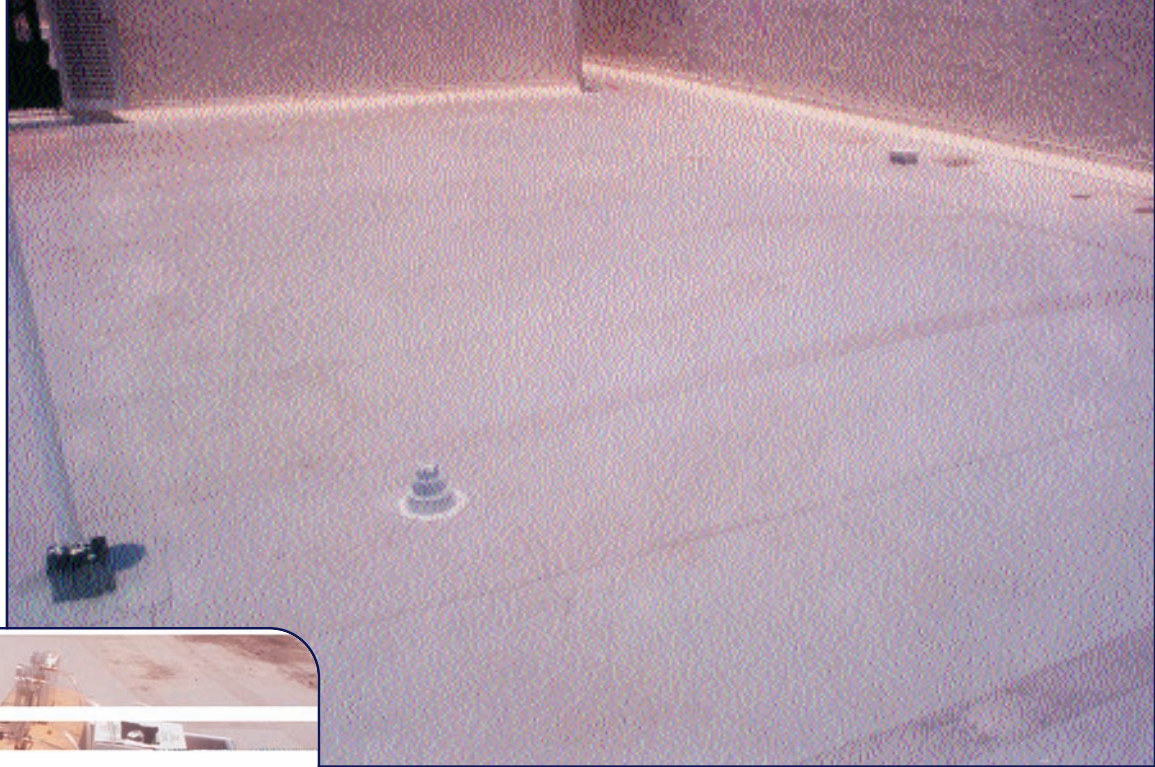

pulse echo) don't relate directly to field applications, but they demonstrate that technology is available for consideration.

#### **Bailey, 1994**

This is a survey of passive leak detection technologies for membrane roofing. The report describes various types of moisture sensors placed within the roofing system, normally during the original construction. These systems differ from non-destructive survey methods in that they are in place and therefore continuously monitor moisture content changes within the roof system.

#### **Bailey, 1998**

This is a follow-up on previous work by the U.S. Army Corps of Engineers. It is a much more specific development of an entire system, including sensors, signal generator, transmission medium, and signal processing units. Again, this relates to having sensors built into the roofing system.

#### **Bryan, 1986**

A leak detection system is described in a U.S. patent. Independent moisture detection units are placed in a specific pattern within a roofing system. These units consist of a moisture detecting unit, power supply, and signaling unit. The power supply is activated when contacts are shorted out by intrusive water.

#### **Darilek, 1998**

The Darilek project summary describes the electrical leak location method for geomembrane liners. This system relies on a

low voltage being imposed on a water covered membrane and grounded to the surface below the membrane. The electrical current will follow the same path as leakage of water through an opening. A signal device is used to isolate the location of the leak.

#### **Rossiter, 1991**

The pulse-echo ultrasonic evaluation for the integrity of seams of the single ply roof membrane is described. By imposing this sonic energy across a field seam, differences in the bond integrity and bond area can be determined. The apparatus is passed over the top of the roofing membrane along the seams. The membrane must have a thin layer of water on the membrane for it to perform. The mechanism is considered developmental.

#### **Sheahan, 1991**

The report of non-destructive methods for determining the integrity of a roof membrane and its seams described two systems. One relates to the testing of seams by using double seams to incorporate an unbonded layer between the adhered portions of the seam. Air and/or a tracer gas is put into the seam via a needle. The expanded shape of the seam denotes the area of bonding while the tracer gas can be detected by a sensor to locate any openings within the seams. See Exhibits 3, 4, and 5. The second system described uses a high-volume, low-pressure fan to inject air with the tracer gas below a roofing membrane. Large areas (as much as 100 squares) can be subjected to the air/gas mixture. The top of the roof was scanned with a sensor device to locate roof leaks. See Exhibits 6 and 7.

### **Review of Commercial Application for Leak Detection for Roof Membranes**

Following is a sampling of commercial roof systems with which the author has had personal exposure. These systems and organizations are listed to demonstrate there have been a number of attempts to develop and implement leak detection systems for roofs. To the author's knowledge, none of these has been adopted by the roofing industry in the U.S.

## Airsure

This is a device to develop a vacuum within a transparent dome. The base of the dome is placed on areas suspected of leakage, and a vacuum drawn. A water-soap solution on the surface of the membrane bubbles when there is a leak.

## Aquaveyor

This system incorporates a matrix of electrical wiring within a roofing system. Connections are made to a computer system and signal device to identify when and where moisture invades the roofing system.

## Chemlink

Ports set onto and penetrating through the roofing membrane are incorporated here. They are set into a pattern that leaves probes permanently below the roof membrane. An electrical resistance device is used to check these ports on a periodic basis or when leaks have occurred. Where water has short-circuited the probes, a reading is obtained, indicating a leak in that vicinity.

## Kwik-Company

This system is based on buried sensors and probes within the roofing system. A port through the membrane is required to allow direct contact to a sensor. These are laid in a predetermined pattern so that the roof can be checked periodically or when there are leaks reported.

## Leak Sensors Inc.

This is a method for locating leaks in pond liners by imposing low-voltage, direct current in a liquid layer above the membrane to a ground below the membrane.

## Mid Systems Inc.

A matrix of electronic units is recessed into the insulation during installation of a roofing system. These sensors contain an encapsulated voltage source that provides a signal, should the circuitry come in contact with water.

## The Romine Company

Offered here is a recessed, insulated screw cap assembly. It differs from most fastener disks in that the fastener head is recessed approximately 1" below the surface of the insulation. This, in combination with a leak detection-type screw, can be used to detect moisture by the dripping of water through the hole made in the metal deck to hold the screw in place. This is of particular use in cold storage facilities because the recessed

screw will not be a point of thermal bridging.

## Southwest Research Institute

This leak location service is for geomembranes, such as pond liners. It relates to the use of low voltage, using direct current through a liquid above a membrane pond liner. A ground below the membrane completes the circuitry. The leaks are found by

recognizing that current flow will be intensified in the area of leaks following the same pattern as water flow through a hole in the membrane. Four papers are identified in the bibliography that relate to this process. They are Laine, 1989; Laine, 1989; Darilek, 1989; and Laine, 1990.

## The Author's Involvement with Leak Detection Methodologies

In 1992, I wrote an article for an industry magazine as a challenge to a previous article by the editor. Her article stated there wasn't going to be a next generation of commercial roofing systems. That was a sad commentary on our industry. Some nine years later, I may concede that it was correct despite the opening in my article which was, "It's Time for a New Approach to Roofing Analysis and Repair. This consultant proposes that the industry incorporate simple, early-warning devices into roof assemblies to facilitate repairs and extend performance." From then until now,

I have been involved in a number of projects attempting to develop early leak detection systems.

The following is a description of these leak detection devices and systems that have impressed the patent office

Exhibit 8

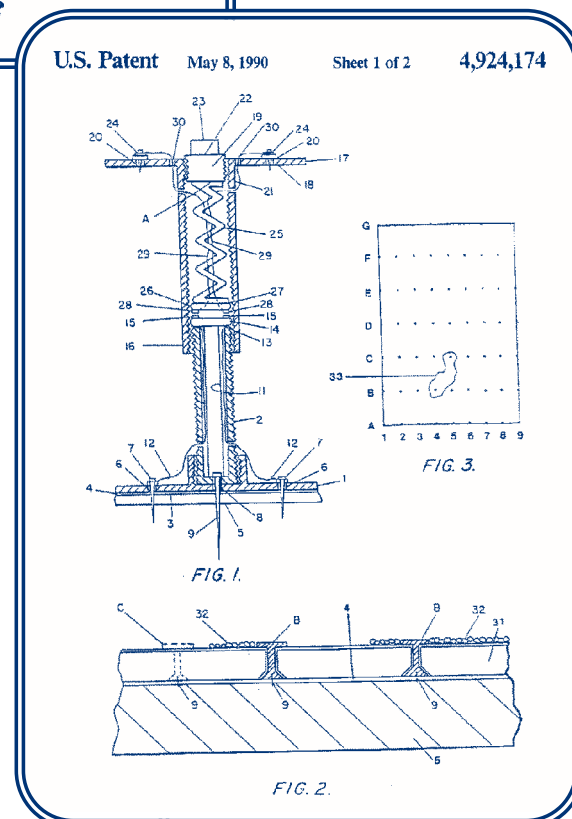
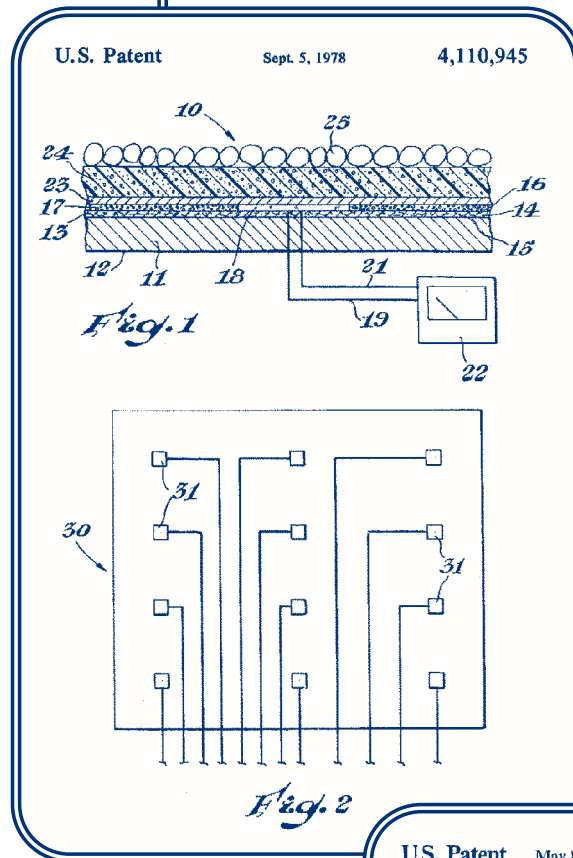

Exhibit 9

more so than they have members of the roofing industry (as none has been adopted by the industry).

**Sheahan, 1978, Exhibit 8**

This patent describes an array of water detectors connected by wires imbedded in a roofing system to detect breaks in the roof system that allow water to invade.

**Sheahan, 1990, Exhibit 9**

This patent describes a hold-down device modified to include a water leak detector. This was initially considered for use in the protected roof membrane system where the ballast material was held in place by hold-down devices that had probes penetrating the roof membrane. The probes could pass a signal based on short circuiting of the probes due to water pick up to a signal device placed on the portion of the device above the roof membrane.

**Sheahan, 1992, Exhibit 10**

This patent describes a combination fastening and leak detection device and the method for its use to secure roofs. The device allows the passage of water down the shank of the fastener to the interior of the room. A ball check on the lower portion of the fastener within the building would prevent the passage of air into the roofing system during high wind conditions.

**Sheahan, 1992, Exhibit 11**

This patent describes the method for leak detection via non-destructive quality control testing of roofing seams. It is based on the use of a double seam with a void space in the center along the length of the seam. Air is injected into the void via a needle, and the void fills with air pressure to a value equal to the bond strength required for the seam. This allows checking of the integrity of the seam. Also, leakage through the seam can be detected by a water/soap solution. This particular concept has been introduced by a manufacturer of a thermoplastic roof membrane to improve fastener withdrawal resistance that utilizes a double-heated hot blade to make a double bond with a void between.

Fig. 4

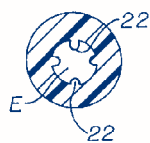

Fig. 5

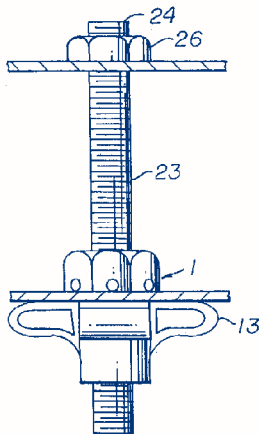

Fig. 6

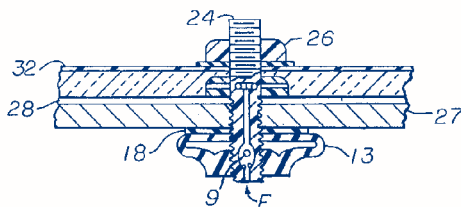

Fig. 1

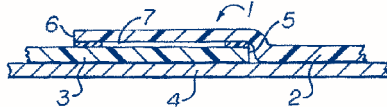

Fig. 2

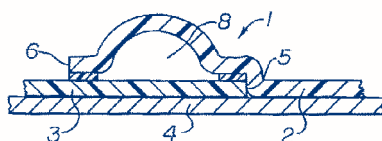

Fig. 3

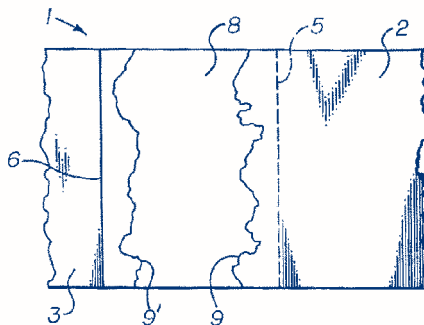

Exhibit 10

**Sheahan, 1993, Exhibit 12**

This patent describes a leak-localizing methodology using a combination of penetrating devices and barriers. This is based on a multi-barrier system, particularly having a barrier as the lowest component of a roofing assembly such as an air barrier or vapor barrier over a metal deck. Water that enters the system flows through the components to be held at the lower barrier level. Openings in the securement fasteners allow water to pass through and enter the room below, denoting the point of leakage.

**Sheahan, 1999, Exhibit 13**

This is an anti back-out roof fastener adapted as a leak detector. The patent describes the use of a recessed fastener disk to allow the fastener to be lowered into the insulation layer then covered with an insulating plug. The fastener incorporates a spring that is compressed when the fastener

is attached to the metal deck below. Water that would pass through the system would be directed to the fastener, and leak water would fall through immediately without accumulating in the roof system. The fact that the screw is recessed allows an application for cold storage use and for recover work where the potential collapse of the insulation would not have the screw head protrude, causing eventual rupture of the membrane.

Exhibit 11

**Sheahan, 2000, Exhibit 14**

This patent describes a leak localizing device using a combination of penetrating devices and barriers with the fastener modified to allow the passage of water down the shank through the screw hole in the metal deck below. This relies on

the use of a barrier system to retain the water at a level immediately above the structural deck and to allow the water to be directed downward through the fastener nearest the leak area.

Exhibit 12

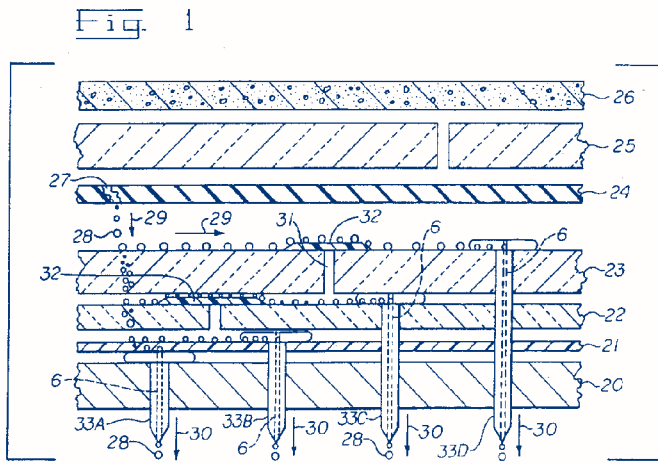

U.S. Patent

May 25, 1993

Sheet 1 of 4

5,212,927

Exhibit 13

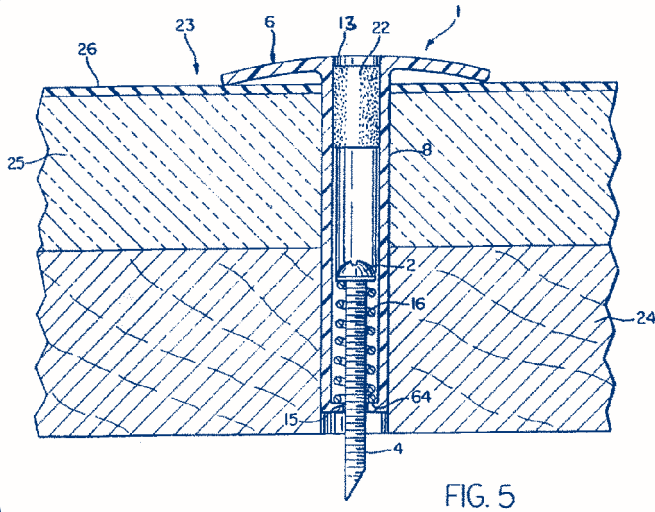

U.S. Patent

Jun. 1, 1999

Sheet 2 of 4

5,907,938

and membranes for roofs have a number of similarities. Both are designed to keep water from passing to the underside. Pond liners carry a head of water, while roofing membranes do not anticipate any appreciable volume of water continually carried on the surface. In many cases, however, it does occur due to ponding, flooding, and snow loads.

There is no living space below geomembranes, whereas there is living space below roof membranes. Even with the fact that the space below roof membranes is far more critical than below geomembranes, leak detection systems have been developed for the geomembrane but not for roofing systems. On that basis, the roofing industry is far behind in protecting interiors with "fail-safe" approaches. There are no

early positive leak localization mechanisms in place that will allow timely repairs with minimum damage to the components and to the space below. Ours may be the only major industry without early warning systems. Automobiles, aircraft, construction equipment, computers, etc., all have early warning systems built in to protect the expensive systems and in many cases to protect people.

There are negative influences with respect to early detection to be considered. There are some who believe that roofs could last too long, thereby reducing the size of the roofing market. The mere incorporation of leak detection methodologies into a roofing system seems to embarrass some by calling attention to the possibility that a roof could actually leak. There is a concerted effort to make roofs impregnable versus having an early warning system. There are some who think there would be a loss of business of providing roof

surveys, roof replacements, and even activities that lead to litigation. Proponents of these negative forces range from material suppliers to contractors and roof consultants. The industry purports to strive for sustainable roofing; roofs that last longer, roofs that have less damage over time, that develop less waste. But all

### Varying Outlooks on Leak Detection

The geomembrane industry is far ahead in implementing early leak detection mechanisms. This is both in the evaluation of seams during construction and methods to determine where leaks occur after construction. The membranes for pond liners



RCI, Inc.  
800-828-1902  
www.rci-online.org

of these benefits are compromised by not having an early warning system for leaks included in the roofing system. Exhibit 15 summarizes this author's recommended approach to designing roofs with superior performance.

## Cost and Benefits

The cost for early warning systems could vary in the range of 10¢ to \$1.00 per square foot. This would be for systems varying from simple modified screws to electronic signal units built into the roofing system. These costs are considered relatively high compared to costs for roofing systems today in the range of \$3 to \$5 per square foot. Taking into account the increased cost of roofing systems with the intention of making roofs more sustainable, the cost for multi-barrier systems to green roof systems could increase to \$10 to \$20 per square foot. The investment cost to protect roofing systems and interiors becomes a very small portion of the total cost.

The benefits obtainable, while qualitative, are definitely cost savings. Examples are:

1. Added years to life of the roof.
2. Reduced system damage.
3. Elimination of costly repairs.
4. Reduced business interruption and damage.
5. Lower insurance cost based on lower potential for damage.
6. Maintaining long-term insulation value.
7. Elimination of need for periodic nondestructive surveys.
8. Reduced warranty service costs and corresponding reduction of warranty fees with fewer limitations.
9. Permits multi-barrier systems with safety for system.

Substituting the present lower-cost system with its potential greater problems with a higher, first-cost system which would have fewer potential problems makes good business sense. The result is more profit up front for designers, contractors, and consultants, even though it means less business due to problem projects. Designers can provide better performing projects to clients. Owners will save money based on life cycle costing and better performance to offset the higher first cost of early warning systems. Most of these schemes are based on the addition of new materials versus providing a service. These are built in during construction for continual use during the entire life of the roof.

Finally, imagine again a futuristic yet plausible early warning system. A roof is a candidate for recover. The layer of insulation and new roofing membrane are installed. Simple probe sensors

are placed on approximately 10' centers. The probes are waterproofed to the new roofing membrane and insulated to leave

only the tips at the bottom to serve as electrical conductors. This will prevent misreading condensation as leaks. Within the sensor waterproofing disk are the simple components of a "Timex-type" watch consisting of a battery which has an approximate two-year life and the chip, designed to keep time. Periodically the sensors are read with a simple signal-receiving device which is similar to the remaining portion of a watch. When the probes are shorted out, the battery starts and the chip keeps track of the time passage. During the investigation, not only are the probes that have become wet identified, but they become wet in a sequence which would allow determining the point of initial entry of water by noting which probe became wet first. This is an intriguing example of a simple, workable system and an opportunity for advancing the capabilities of the roofing industry with benefits for all concerned. ■

Exhibit 14

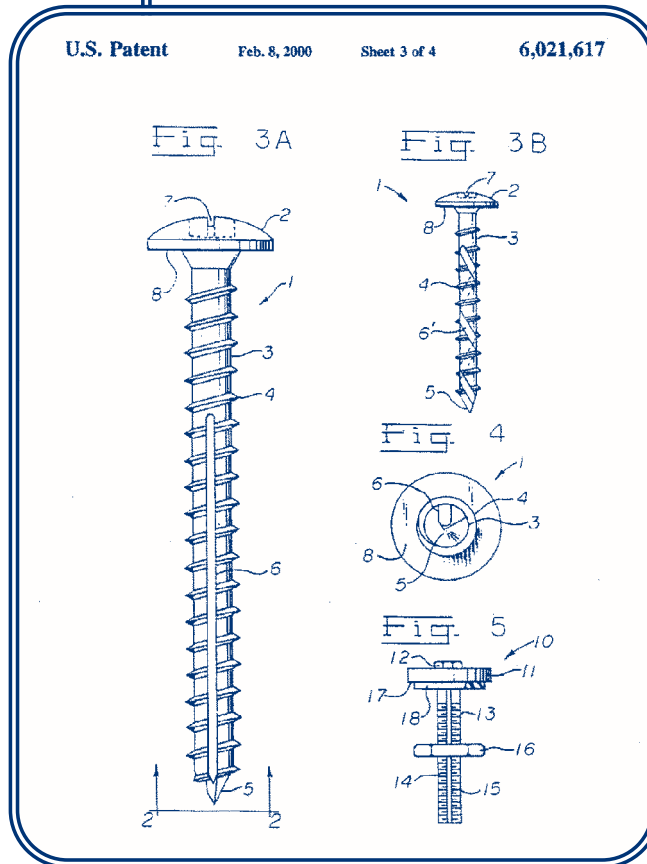

## References—Industry

- ASTM D-4545-86, "Standard Practice for Determining the Integrity of Factory Seams Used in Joining Manufactured Flexible Sheet Geomembranes" Philadelphia: American Society for Testing and Materials, 1986.
- Bailey, D.M., Ditman, J., Dupuis, R., Buckner, A. "Survey of Passive Leak Detection Technologies for Membrane Roofing." *USACERL Technical Report FM-94/04*. Champaign: US Army Corps of Engineers Construction Engineering Research Laboratories, 1994.
- Bailey, D., Prell, A., Coad, C., "Laboratory Investigation of Selected Sensors for Use With Passive Roof Leak Detection Systems," *USACERL Technical Report 98/09*, US Army Corps of Engineers Construction Engineering Research Laboratories, January 1998.
- Bryan, B.O., "Leak Detection System for Roofs" *Patent # 4,598,273*. July 1, 1986.
- Darilek, G., Parra, J., "The Electrical Leak Location Method for Geomembrane Liners," EPA, Project Summary, *EPA/600/S2-88/035*, September 1998.
- Rossiter, W., Watanabe, H., "Pulse - Echo Ultrasonic Evaluation of the Integrity of Seams of Single-ply Roof Membranes," *Third International Symposium on Roofing Technology, Montreal*, U.S. National Institute of Standards of Technology & National Roofing Contractors Association, 1991, pp. 72-83
- Sheahan, J., Johnson, J., "Nondestructive Methods for Determining the Waterproof Integrity of Roof Mem -

# AUTHOR'S TRUISMS

1. **Roof design should plan on leaks.**
2. **Don't use water-sensitive materials in a roof.**
3. **Don't rely on perfect design, installation, materials, and quality control.**
4. **Design roofs to make leaks detectable.**

## Exhibit 15

branes and Seams," *Third International Symposium on Roofing Technology*, National Institute of Standards of Technology & National Roofing Contractors Association, 1991, pp. 55-62.

Sheahan, J., "Diagnosing Roofing's Ills," *Roofing Siding Insulation Magazine*, May 1992, pp. 42-49.

Sheahan, J., "Methodology for Timely and Efficient Leak Detection," Roofing Consultant Institute Convention, March 1992.

Sheahan, J., "Roof Installation for Locating Water Leakage Points," *U.S. Patent 4,110,945*, September 5, 1978.

Sheahan, J., "Hold Down Device Modified to Afford a Water Leak Detector," *U.S. Patent 4,924,174*, May 8, 1990.

Sheahan, J., "Fastening and Leak Detected Device and Method for Its Use to Secure Roofs," *U.S. Patent 5,080,542*, January 14, 1992.

Sheahan, J., "Method for Leak Detection and Non-destructive Quality Control Testing for Roofing Seams," *U.S. Patent 5,143,568*, September 1, 1992.

Sheahan, J., "Leak Localizing Using a Combination of Penetrating Devices and Barriers," *U.S. Patent 5,212,927*, May 25, 1993.

Sheahan, J., "Anti Backout Roof Fasteners," *U.S. Patent 5,097,938*, June 1, 1999.

Sheahan, J., "Leak Localizing Using a Combination of Penetrating Devices and Barriers." *U.S. Patent 6,024,617*, February 2000.

## References—Commercial

1. **Airsure.** The localized vacuum method to determine leaks. Retro-Specs Centre, Manitoba, Canada. Method to impose vacuum over suspected leak areas in membranes to determine leakage.
2. **Aquaveyor**, November 1990. Aquaveyor Systems Limited — England. A computerized moisture detection facility built in to flat roofing systems to provide immediate warning and location of leaks.
3. **Chemlink Inc.**, Kalamazoo, Michigan. Installation of permanent ports into roofing membrane used for periodic testing without having to make holes in membrane.
4. **Kwik Company** "Kwik-Test," New Caney, Texas. A method of installation of permanent port for future test-

- ing for leaks in roofing membrane.
5. **Leak Sensors Inc.** The Leak Detection & Locator Service, Leak Sensors, Inc. — West Hartford, Connecticut. Method for locating leaks in pond liners by imposing low voltage direct current in liquid layer above membrane to a ground below membrane.
6. **Mid Systems Inc.** "Moisture sensing and alarm systems" — Matthews, North Carolina. Installation of active sensors in matrix form throughout roof system provides signals indicating when leaks occur.
7. **The Romine Company** Recessed insulated screw cap assembly. — Newark, Ohio. Recessed fastener head device that can be used to house leak detecting screw.
8. **Southwest Research Institute.** Geomembrane leak location service. — San Antonio, Texas. The application of low voltage direct current power through liquid membrane cover over pond liners to a ground located below the membrane for use in the location of leaks in liner.

## Bibliographies

Darilek, G., Laine, D., Parra, J., "The Electrical Leak Location Method for Geomembrane Liners — Development and Applications." *Industrial Fabrics Association International Geosynthetics Conference*, February 21-23, 1989 - San Diego, California.

Laine, D., Miklas, Jr. M., "Finding Leaks in Geomembrane Liners Using an Electrical Method: Case History," *HMC*, June 1990, pp. 29-37.

Laine D., Mikals, Jr. M., "Detection and Location of Leaks in Geomembrane Liners Using an Electrical Method: Case History," *Superfund 89 10<sup>th</sup> National Conference*, Washington, D.C., November 27-29, 1989, pp. 35-40.

## ABOUT THE AUTHOR

**James P. Sheahan** is a past president of RCI. From 1959 to 1978, Jim gained experience in many facets of the construction industry—primarily in waterproofing and insulation—through his work with Dow Chemical Co. In 1979, he formed J.P. Sheahan & Associates Inc. He is a Registered Roof Consultant and has been a member of the Cellular Plastics Division of the Society of Plastic Industries (SPI), of CSI, ASTM D-08, and BTECC. Jim has 15 patents on roof-related products. He flies his own plane and lives with wife Jan in Midland, Michigan.



**JAMES P. SHEAHAN**