

WET CONCRETE DECKS:

Problems and Practical Solutions

BY COLIN MURPHY, RRC, FRCI

Over the years, the author has experienced a number of roofing projects where concrete decks have contributed to latent defects within newly installed roof assemblies. Our investigations and subsequent remediation of the roofing assemblies prompted this article. Its purpose is to identify both the design and installation challenges and to provide recommendations that will maximize success in these types of applications.

In theory, concrete decks placed over steel pans can make ideal substrates for roof systems. In practice, they can be ill-suited for the roof and associated insulation assemblies. Concrete decks can – depending on some significant variables – hold water that, over time, rises into the assembly once the roof is in place. Due to a combination of design and construction conditions, a concrete deck can retain water for extended periods, resulting in the saturation of moisture-sensitive components and subsequent creation of blisters between the cover board and the roof membrane.

A new construction roof design begins with collaboration between architect and structural engineer. Initial structural design (i.e., wind, seismic loads, live and dead loads, etc.) will dictate much of the deck criteria. There may also be specific architectural deck criteria to meet the building use and building owner requirements. Type and gauge of steel decking, concrete type and mix, and placement of reinforcing are then determined.

The steel pan supports the concrete and provides the locking mechanism to form a composite. The mechanical connection between the concrete and the steel pan is

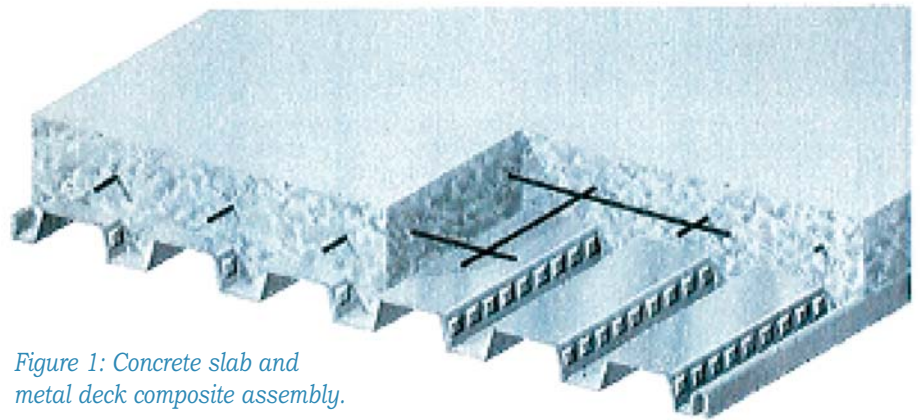

Figure 1: Concrete slab and metal deck composite assembly.

created by indentation patterns punched in the vertical leg of the pan profile.

Positive roof drainage is achieved by:

- 1) Sloping the structural steel members; or
- 2) By an additional pour of lightweight concrete over the structural slab; or
- 3) By installing tapered insulation over a flat concrete slab.

The physical and performance properties of the concrete, including compressive strength, density, slump, and allowable admixtures, are also defined within the structural specifications. The concrete slurry is restrained within the metal profile, eliminating the need for control joints in the slab. Structural expansion joints are cut through all components or formed with pour stops to allow for building movement.

During the casting and curing process of the slab, conditions may occur that will allow for the retention of water. Voids, such as rock pockets, can form reservoirs at the deck interface. These voids can be recharged with additional water percolating through the slab.

If the steel pan is solid, any water that enters the slab can become trapped.

To a large extent, cracking is a function of mix design. Low water-to-cement ratios are not only important for concrete strength, they also reduce the likelihood that capillary voids will form from mix water not used in the hydration process. These capillary voids can be relatively large in comparison to other voids commonly experienced in cured concrete and can notably increase the overall permeability of a concrete roof deck. Low water-to-cement ratios are achieved through careful aggregate selection and through the use of admixtures. Some mix water will not be consumed during curing; therefore, there should be provisions to allow water to escape.

Mostly due to its relative low density (compared with the other ingredients in concrete), mix water rises to the top of the slab; however, an impervious layer at either face of the concrete slab can serve to trap water not used in the hydration of the cement. At the upper surface of deck, this may occur if the smaller aggregate or fines form a film or laitance. These fines can cure

Figure 2: Roofing over concrete deck assembly cut away.



to a film, forming a moisture barrier. Poor placement practices can create an additional problem as rock-pocket voids can form at the bottom face of the roof deck. Concrete cure water in combination with water that enters cracks in the slab can become trapped within the rock pockets, resulting in a water reservoir between the concrete and the steel pan.

A number of field application techniques can exacerbate slab pitfalls over the solid steel pan. A solid pan can retain water if there is residual mix water not consumed in the hydration of the cement and/or rainwater that percolates through cracks to the steel pan interface. Voids in the concrete can accumulate water, which will run to low points in the pan and remain for an extended period of



Figure 3: Core into a concrete slab to the steel pan below.

time. Changes to the concrete mix, such as the addition of water on site (a common practice used to increase workability and facilitate placement), can change the mix and make it more susceptible to moisture retention. This can increase the number of capillary voids, the permeability of the concrete, and quantity of the mix water not consumed in the hydration of the cement.

The curing methods employed can also play a role in surface cracking of the concrete pour. Weather, during both the casting and cure, will play a significant role in the suitability of the deck as a roofing substrate since a primary source of the water will, in virtually all cases, come from precipitation. Generally speaking, about half of the mix water will be consumed in the chemical cur-

ing process. Depending on the prevailing atmospheric conditions, a typical concrete deck may take months to rid itself of excess water. Ideally, unused mix water will migrate to the upper surface and evaporate prior to the application of roofing materials. Some water will also migrate downward and accumulate at the slab and pan interface. Fluted decks with perforations or steel decks that have been breached will allow for this moisture to pass to the interior.

Concrete decks typically cure for a period of 28 days to reach design strength. During this four-week period, the deck is exposed to weather, including rain. In some cases, the concrete surface is treated with sodium silicate or other chemical compounds to bind the free lime, reducing the penetration of water

into the slab. Roofing usually begins when the moisture levels are low enough to ensure a quality bond between the deck and the adhesive materials used to bond the first roofing component. Some of the more common test methods used to determine the suitability of the deck as a bonding substrate include:

- **Asphalt Pour Test (traditional roofing method):** a pint of hot asphalt is poured onto the deck at the specified temperature to determine if a bond is formed between the asphalt and the concrete deck. If the asphalt begins to froth or the cooled asphalt can easily be peeled from the deck, it is not, at the time of testing, suitable for asphalt application.

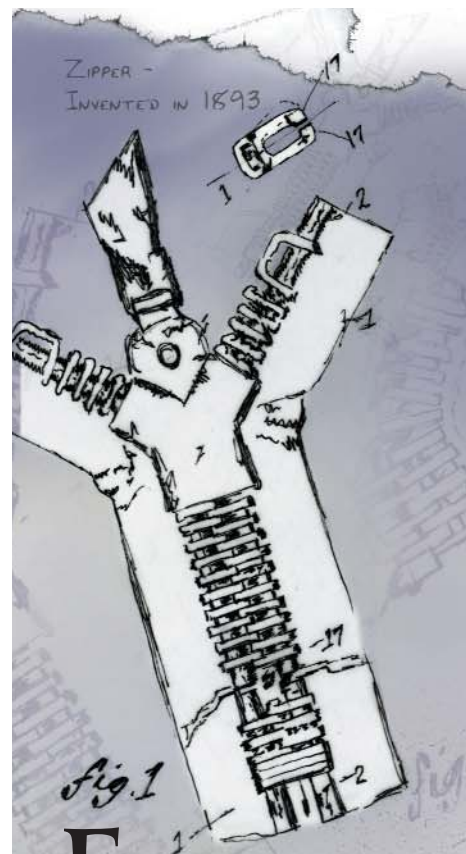

FiberTite, and some other good ideas, have passed the test of time.

Our tradition for holding things together runs deep. The fact is, our idea for FiberTite membranes came from our successful hazardous waste landfill liners. We figured if our technology can protect the environment for up to 50 years, protecting your building would be a snap. Warranties? Ours is as good or better than anybody's, but you'll probably never need it. Call 800-927-8578 and we'll zip you the facts. Or visit www.fibertite.com.



**INTELLIGENT
ROOFING SOLUTIONS**

This “litmus test” only addresses the moisture content within approximately the first inch of the concrete pour and will not detect moisture that may reside deeper in the slab.

- **The Black Mat Test (ASTM D-4263):** A black mat formed from EPDM or polyethylene is applied to the deck surface and taped at the edges. The mat is kept in place for a period of 16 hours. After exposure to sunlight for the specified period, the mat is removed to reveal either a dry or wet surface. This test is a “pass or fail” method of determining whether or not there is moisture in the slab that could rise and inhibit the bond of the adhesive to the concrete deck. This test typically provides data on only the top one to two inches of the slab.

- **Calcium Chloride Test (ASTM F-1869):** A test kit includes a tray containing calcium chloride crystals inside a chamber that is sealed to the surface of the concrete deck. The crystals will absorb water over the 60- to 72-hour test period. At the conclusion of the test, they are removed and weighed. Based on the measured moisture, a

formula is applied that provides the number of pounds of water that are emitted from the slab surface per thousand square feet per 24-hour period. The test results indicate the quantity of water emitted over the test period, not necessarily the quantity of water within the slab. The test is relative, providing data as to the suitability of the surface to the application of adhered materials.

- **Impedance Testing (commonly referred to as Capacitance Testing):** Concrete-specific moisture meters are commercially available, and when calibrated to laboratory-tested concrete core samples, can effectively measure the relative moisture on the surface (within one-

inch) of the slab.

During the cure period, water (either from rain or wet curing techniques) can accumulate and run over the exposed slab surface. If the deck is sloped, water will run to drains or scuppers. Water will accumulate in depressions and enter cracks in the concrete and transitions between the slab and penetrations such as curbs, rising walls, plumbing vents, and structural expansion joints. Flutes in the metal pan hold water within linear cells, limiting the distribution of the water throughout the slab. Periods of intense heat such as hot summer days will evaporate some of the accumulated water at the deck surface. The extent of evaporation will depend on the time of year and the intensity of the sun-



Figure 4 (above) and Figure 5 (right): Poor adhesion of primer over a wet concrete substrate. Long night seals can be sources of water under newly installed roof assemblies.

light. In addition, the intensity and duration of rainfall determine the amount of water that can enter the slab, recharging any water that may be removed as a result of high surface temperatures.

After roof installation begins, more water can accumulate under the newly installed roof assembly, destroying in-place components. A typical roof installation begins at the low point, working to the high points of the deck. To protect the assembly from water entry, long night seals or waterstops are needed at the edge to prevent water from penetrating under the newly laid assembly. Should there be rain after completion of a

day’s work, water will build up on the high side of the tie-offs, creating a head of pressure at the seam. Even a minor imperfection in the seal can allow substantial amounts of water under the newly installed roof assembly. Water cannot flow to the drains until it builds up to the height of the new roof assembly. The water is trapped at the night seal, seeking a point of entry.

Creative means and methods can maintain water paths to drains and divert water away from night seals; however, they are rarely employed, especially on very large roof installations where a night seal can run hundreds of feet.

In tropical and semi-tropical zones, the problems can be more acute. These zones are more prone to hurricanes where concrete decks are specified to resist higher wind loads. Curing of large concrete slabs in tropical zones is especially difficult due to extreme daytime temperatures and daily rainfall. The short but intense rains challenge the best of roofers in maintaining an “uphill water cut-off.” While these can be common challenges in tropical and subtropical areas, similar problems can occur further north where unusual rain patterns can bring greater than normal rainfall during the period of slab cure and roof installation.

Traditional test methods to determine the presence and levels of moisture within the slab are not designed to measure mois-



ture trapped within the composite and within concentrated areas of cracks. This moisture may well elude the typical test methods, providing a false reading of “dry.”

Even when deck surfaces are not tested for moisture levels, there can be clear signs of inadequate bond, even during the application of primer. High levels of moisture within the concrete will inhibit the bond

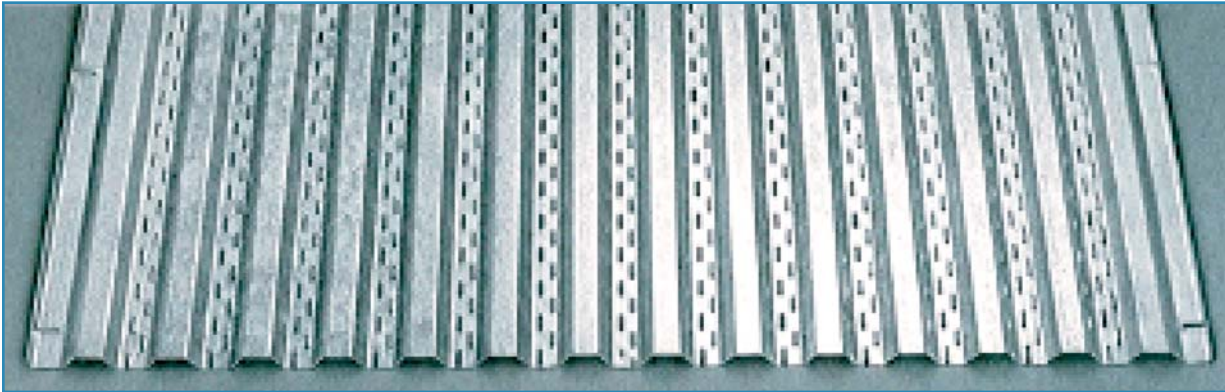

Figure 6 (left) and Figure 7 (below): Perforated steel pans.

between the primer and the deck. Figures 4 and 5 show poor adhesion of the primer during the removal of a night seal, exposing the concrete surface.

On this specific project, poor adhesion of the primer was identified after roofing had commenced. The concrete deck surface was tested for moisture using calcium chloride test kits. Test results indicated that within a 24-hour period, moisture levels emitted from the concrete were 22 pounds per thousand square feet of deck. This equates to 2.75 gallons of water emitted from the 4-inch slab per thousand square feet. For comparative purposes, vinyl flooring should not be applied to a concrete slab when emitted moisture levels exceed 3 pounds per thousand square feet. A hand-held capacitance meter that was not calibrated to a core sample indicated the deck surface was below 10% at the time roof installation commenced. This is a further indication that caution should be used with current test methods – especially when there is a thick concrete pour.

If the presence of moisture within the concrete slab is a potential challenge in the application of a successful roof assembly, what steps can be taken to minimize or eliminate the impact of the presence of water?

The Steel Deck

Specify a perforated deck assembly that will allow for the mechanical connection of the concrete to deck but will also allow for the exfiltration of water from the composite assembly. Perforated steel pans are available from most suppliers. Engineering data as to performance are readily available through the Steel Deck Institute and roll formers of the deck profiles. This one change in the specification will significantly reduce the potential of trapped water with-

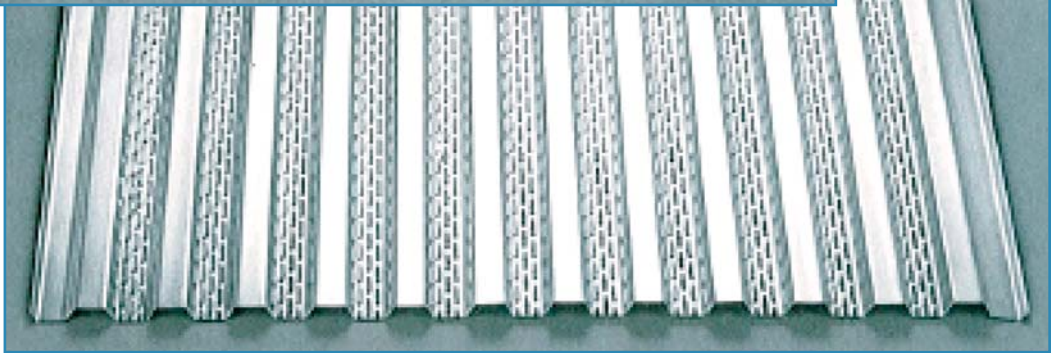

in the composite deck. In most cases, there is some extrusion of the concrete slurry through the perforations in the deck; however, this is only a concern when the deck is

exposed to the interior space. If the underside of the deck is painted, minor amounts of concrete exposed on the underside are hardly noticed.

**THE SOLUTION
FOR DECKS
OVER OCCUPIED SPACE**



BISON DECK SUPPORTS



Call or Visit us Online at:
www.BisonDeckSupports.com
 Toll Free 888-412-4766



The Concrete Mix

The concrete mix should have low water content. It should also be free of admixtures that can inhibit the adhesive bond or damage components of the roof assembly. The submittal process should include a transfer of the admixture data to the roof membrane manufacturer for review and acceptance prior to the concrete pour. Care should be taken during the curing process to avoid alteration of the mix to enhance transportability. The addition of water can change critical properties of the concrete, making it more susceptible to water retention and the formation of capillaries.

Crack Control

While it is not feasible to eliminate shrinkage cracking in a concrete roof deck, it can, for the most part, be controlled. Even with appropriate crack-control techniques, the flutes and indentations in a steel deck will have the effect of partial restraint of the concrete within the composite deck, which may cause hairline cracks to develop throughout the concrete as it cures. These small cracks can be sources of water entry into the composite assembly. Hairline cracks in the concrete surface are inevitable. Covering the deck with plastic or wet tarps as a part of the cure process can minimize water entry but will not totally eliminate it. If the steel deck is perforated and the concrete mix is designed to minimize residual moisture after cement hydration, hairline cracking and subsequent water entry at penetration joints should not significantly contribute to the long-term accumulation of water.

Chemical treatments such as sodium silicate can be applied to the deck surface that will bind the free lime on the top 1/16" of the deck surface, maximizing bond strength of the adhesives to the concrete

surface and minimizing water entry into the concrete. There are numerous commercially available surface preparations that can be utilized for this purpose. Care should be taken to ensure the treatment is compatible with the intended roof assembly and related adhesives.

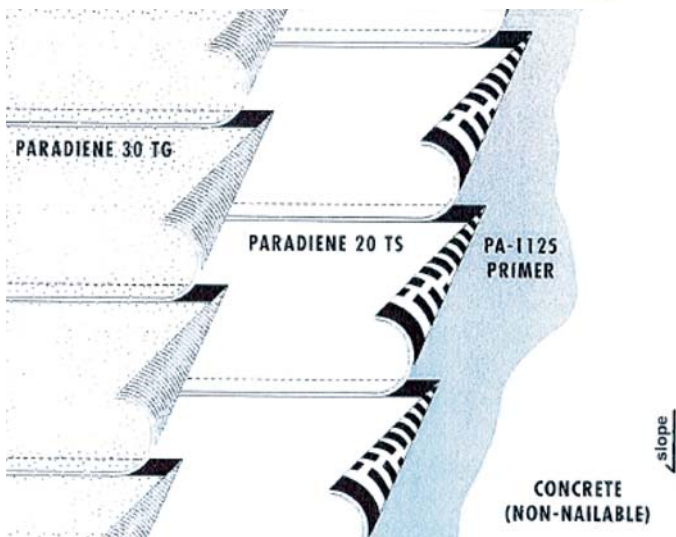

Figure 9 (above): Example of semi-adhered modified bitumen base sheet.

Figure 10 (right): Steel deck with perforated flutes.



The Roof Assembly

The type of roof assemblies designed for this application can also minimize the impact of moisture within the deck assembly. These types of roof systems should be considered when a roof must be applied before the completion of the 28-day cure, when some level of residual moisture can be expected. The deck must be dry enough to accept ASTM D-41 primer or other adhesives, creating a strong bonding interface between the concrete deck and roof assembly components. The adhesion should be tested prior to full-scale application of any

Figure 8: Example of spot-attached base ply installed in an "over-mopping" of asphalt over a primed deck.

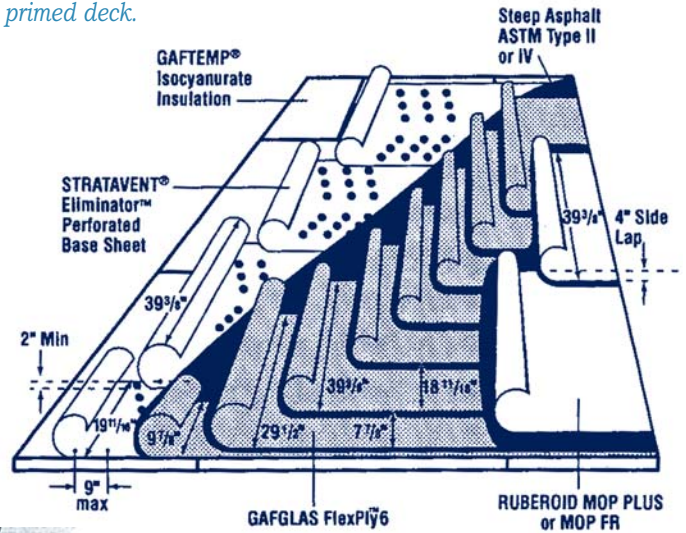

roofing. The following are some design considerations that can assist in the control of moisture, should it be present in the concrete deck.

Base Sheet and Vapor Retarder

The first membrane layer can be applied in a spot-attached manner to allow for the lateral movement of moisture below the roof assembly. This can be achieved by the application of spot-attached systems that are available in both self-adhered and torch-applied configurations.

In addition, spot-attached base sheets that are applied dry and mopped over with hot asphalt, creating intermittent points of attachment, have been available for years. The spot-attached base plies have been tested for high wind uplift capabilities and have credible test data to indicate they can provide service in most high-wind uplift conditions.

The spot-attached sheet can form the base for the vapor retarder or the base ply for the roofing assembly, depending on the specified system.

Vented Base Flashings

The spot-attached base sheet will allow for the lateral movement of moisture under the base ply. This moisture must have a point of egress or it will eventually enter the roof assembly. To remedy this, metal upstands can be installed at the perimeter, allowing moisture to migrate and exit the roof assembly. Joints in the metal are

Figure 11:
Splice plate for
perimeter
upstand.

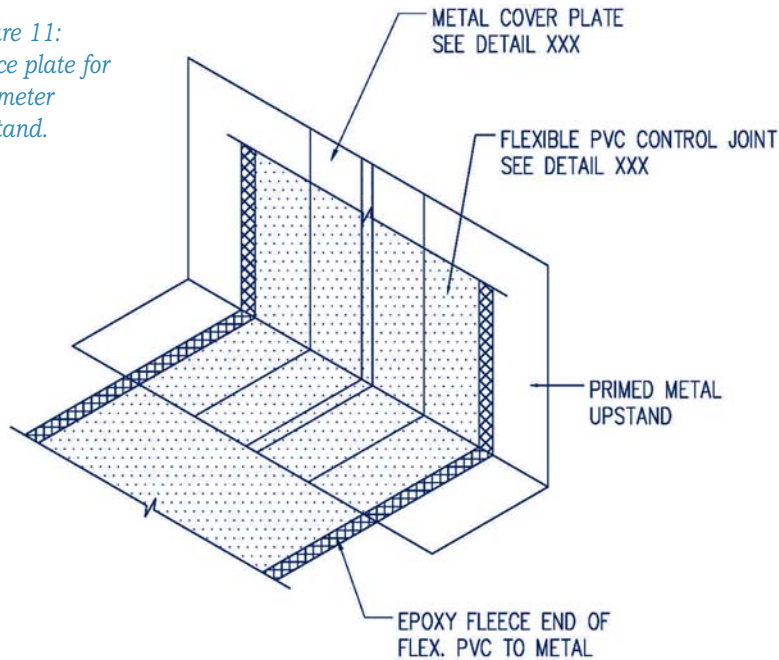

closed with a metal cover plate secured to one side and allowed to move on the other.

Membrane Venting:

One-way vents are available to allow for the release of moisture within the deck and roof assembly without allowing moisture to

pass back into the roof assembly. These vents have proven effective in small areas around the vent only. To be effective, a high density of vents is needed, but the use of a large population of vents must be weighed against the many penetrations in the membrane and the resultant potential for leaks.

THE HUGGER ADVANTAGE ROOF HUGGER™

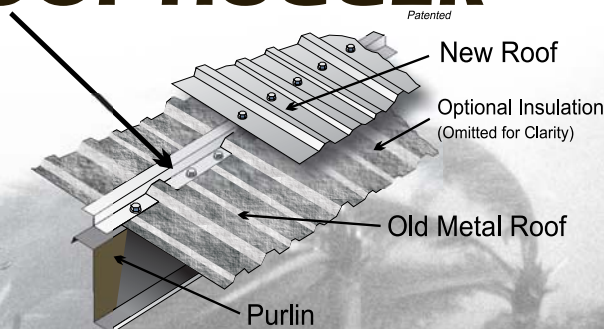

FAST! EASY! And STRONGER!!

**No Need To Remove Old Roof... No Disruptions
10' Lengths, Fit ANY Profile, 16 ga., 50 ksi, G-90 Steel**

**Fully Tested with Certified Load Charts
HUGGERS Can Even INCREASE the STRENGTH of your Old Roof**

**For Retro-fitting Roofs
The RIGHT Way!**

Call: 1-800-771-1711

Or fax us at: 1-877-202-2254

Visit our website at:
www.roofhugger.com

ROOF KNOWLEDGE ASSESSMENT

Test your knowledge of roofing with the following questions, developed by Donald E. Bush Sr., RRC, FRCI, PE, chairman of the RRC Examination Development Subcommittee.

1. According to the updated *FM Global Property Loss Prevention Data Sheet 1-29 (FMGPLPDS 1-29)*, dated January 2006, what is the distance required between rows of single-ply roof cover fasteners or batten bars at the roof perimeter?
2. As a continuation to question number 1, what is the distance required between rows of single-ply roof cover fasteners or batten bars at the roof corners?
3. According to *FMGPLPDS 1-29*, dated January 2006, when is a proportional increase in deck securement required due to field of roof spacing between rows of single-ply membrane fasteners?
4. Batten bars and fastener rows used with mechanically attached, single-ply membranes and multi-ply covers with mechanically attached base plies are to be installed perpendicular to steel deck ribs. What is the exception allowed for Class 1-75 and below systems?
5. For roof system components adhered with asphalt or other adhesives in ribbons, spots, etc., the number of ribbons or spots per unit width or area must be increased over the FM-approved field of roof spacing by what percentage?

Answers on page 10

ROOF KNOWLEDGE ASSESSMENT

Answers to questions on page 9:

1. Equal to or less than 60% of the FM-approved roof field spacing.

Reference: Paragraph 2.2.7.2.1

2. Equal to or less than 40% of the FM-approved roof field spacing.

Reference: Paragraph 2.2.7.2.1

3. When the (field of roof) spacing between rows of single-ply membrane fasteners exceeds 6 feet.

Reference: Paragraph 2.2.7.3.4

4. Fastener rows and batten bars can be installed parallel to the building edge within the defined building perimeter width if:

- The distance between fastener rows in this area is equal to or less than 3 feet; and
- Two FM-approved deck fasteners or minimum 5/8-inch-diameter welds are installed through each lower deck flange (every 6 inches).

Reference: Paragraph 2.2.7.3.2

5. 70% in the roof perimeter. In the case of asphalt or other adhesives applied in ribbons, this results in a maximum, on-center ribbon spacing equal to 40% of the field of roof spacing.

Reference: Paragraph 2.2.1.5.2

Reference: *FM Global Property Loss Prevention Data Sheet* 1-29 (Jan. 2006)

Figure 12: Metal up-stand at perimeter to allow for venting.

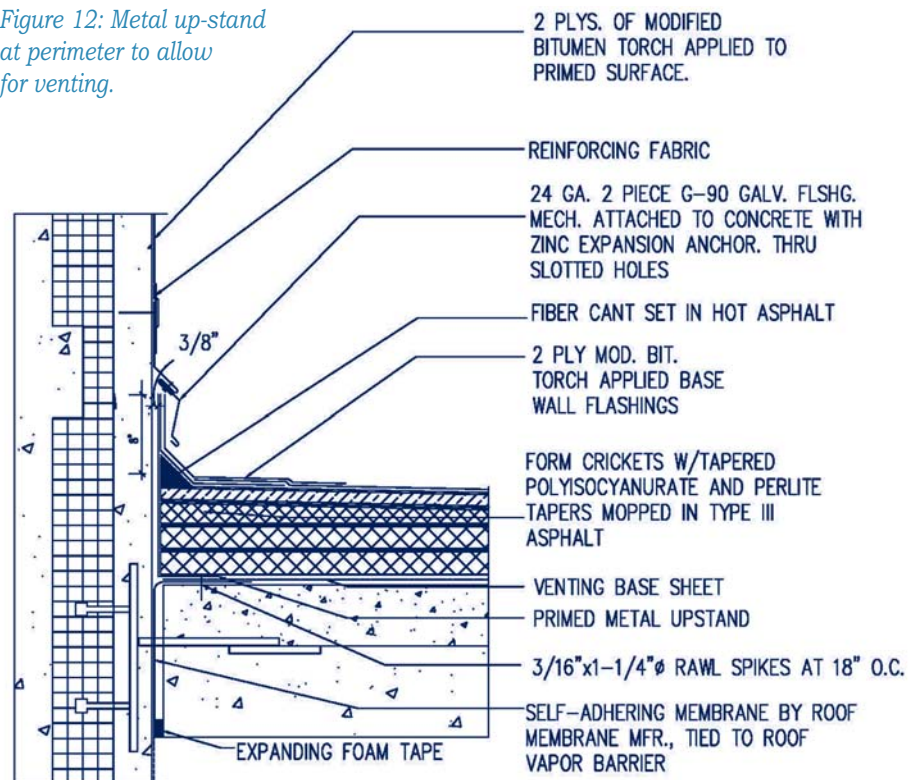

Crickets and Saddles:

Moisture gain in perlite or wood fiberboard may be a result of moisture within the deck; however, it may also be a result of other application conditions that may allow surface moisture to enter the roof assembly. These potential sources of water are comprehensively addressed in an article authored by Richard Canon, entitled, "Infiltration of Moisture into Perlite Crickets and Saddles."¹

CONCLUSIONS

Concrete roof decks are, in most circumstances, an excellent substrate for the application of roofing assemblies. The design and construction of the deck will determine the potential for moisture retention and the suitability of the roof assembly.

Roofing and accessory materials are

available to design wind-resistant roof assemblies that will tolerate some level of elevated moisture within the concrete deck and provide points of egress to protect the roofing components.

The structural engineer, architect, and roof consultant must collaborate throughout all stages of design to minimize water retention in the deck and to choose the optimal roof assembly for the project.

The structural slab should be tested prior to application of roofing to ensure that there is minimal moisture present. 

References

- ¹ Richard P. Canon, RRC, FRCI, PE, "Infiltration of Moisture into Perlite Crickets and Saddles," *Interface*, July/August, 1993. Reprinted from *Roofer Magazine*.

Colin Murphy, RRC, FRCI

Colin Murphy founded Exterior Research & Design, LLC (originally Trinity Engineering, Inc.) in Seattle, Washington, in 1986 and has since expanded the firm to include offices in Waterbury, Connecticut, and Portland, Oregon. Colin is a Registered Roof Consultant and has been elected to the RCI Jury of Fellows. He also is a LEED-Accredited Professional, a certified EIFS Third-Party Inspector, and an ICC-certified Building Inspector. Colin is the principal author of *The Roof Construction Guide for General Contractors*, published in 1998 by RCI. He has been honored with both the Richard M. Horowitz and the Herbert Busching awards by RCI.

