

THE

"WINDS OF CHANGE"

IN ASPHALT SHINGLE SPECIFICATION AND APPLICATION

BY EDWARD L. FRONAPFEL, PE

During the 1990s, asphalt shingles and other roof coverings were found to perform below reasonable expectations during multiple hurricanes. This fact is reiterated by the publication of the *Wood Building Performance and Analysis* (Bradford K. Douglas, PE, a special report of the National Forest Products Association, November 1992). The roof coverings (shingles) were the first portions of the buildings that failed during Hurricane Andrew. This failure included both asphalt and tile roofing products. The reason cited for the failures was inadequate fastening. The blow-off of roofing products resulted in exposure of the underlying structure and also produced wind-borne projectiles that resulted in damage to other structures. The fact that shingles and other roof coverings fail under high wind patterns has been known in the industry for decades. Yet, based on our review of installation and testing requirements, only a few manufacturers had apparently dealt with this prior to the early 2000 timeframe.

The Federal Emergency Management Agency (FEMA) prepared *Asphalt Shingle Roofing for High-Wind Regions, Recovery Advisory 2*, to recommend practices for installing shingles that will enhance their wind resistance in high-wind, hurricane-prone areas (both coastal and inland). Some key issues included special installation

methods for asphalt roof shingles used in high-wind, hurricane-prone areas defined as those areas with greater than 90-mph, 3-second peak gust design wind speed.

Based on this document, the roofing contractor should utilize wind-resistance ratings to choose the project shingles. They should not rely on these ratings alone for performance standards, but on the techniques used for proper installation of the shingles, underlayment, and edges to provide a well-constructed project in conformance with the manufacturers' and industry standards. A poorly installed product will simply perform poorly. According to Malarkey Roofing Products, "One of the most critical elements of a successful roofing project is correct installation of the shingle. Market research has shown that most laminated shingles are incorrectly installed due to improper fastener placement."

The installation of shingles is a pivotal concern in proper construction. Partnership in Advancing Technology in Housing (PATH) states, "Between 1991 and 1995, wind and hail resulted in an average of \$8 billion in insurance payouts each year, and wind and hail damage to roofs comprises a significant portion of this cost. Hail damage to asphalt shingles may include severe granule loss, material loss at shingle edges, and impact damage. Wind can also create serious roof damage. It is documented that roof-covering failure due to installation and

product selection was the most widespread type of damage from Hurricane Hugo (Manning, Billy R. and Gary G. Nichols. 1991. 'Hugo Lessons Learned.' in *Hurricane Hugo One Year Later*, Benjamin A. Sill and Peter R. Sparks, Editors. New York: American Society of Civil Engineers)."

The damage to systems by wind occurs not only in the hurricane-prone coastal regions of the United States, but also in a number of additional high-wind regions within the United States. The damage is not always associated with just shingle loss, but subsequent damage to the underlying structures and possibly even damage to adjacent buildings.

Recently, Professional Investigative Engineers (PIE) was called out to look at damaged glass windows in Littleton, Colorado. The reported wind gusts were between 80 and 90 miles per hour (3-second peak gust) versus the minimum design wind-load requirement of Jefferson County of 100 mph exposure C (3-second peak gust). The conclusion of the investigation was that the mulled window assembly did not break because of the structural issues of the unrated mullion. The damage was a result of wind-blown shingle debris from the neighboring townhomes. The shingles were torn or their attachment compromised by wind uplift from the adjacent roofing systems. The shingle product utilized on the townhomes was neither rated nor constructed for the region's wind requirements.

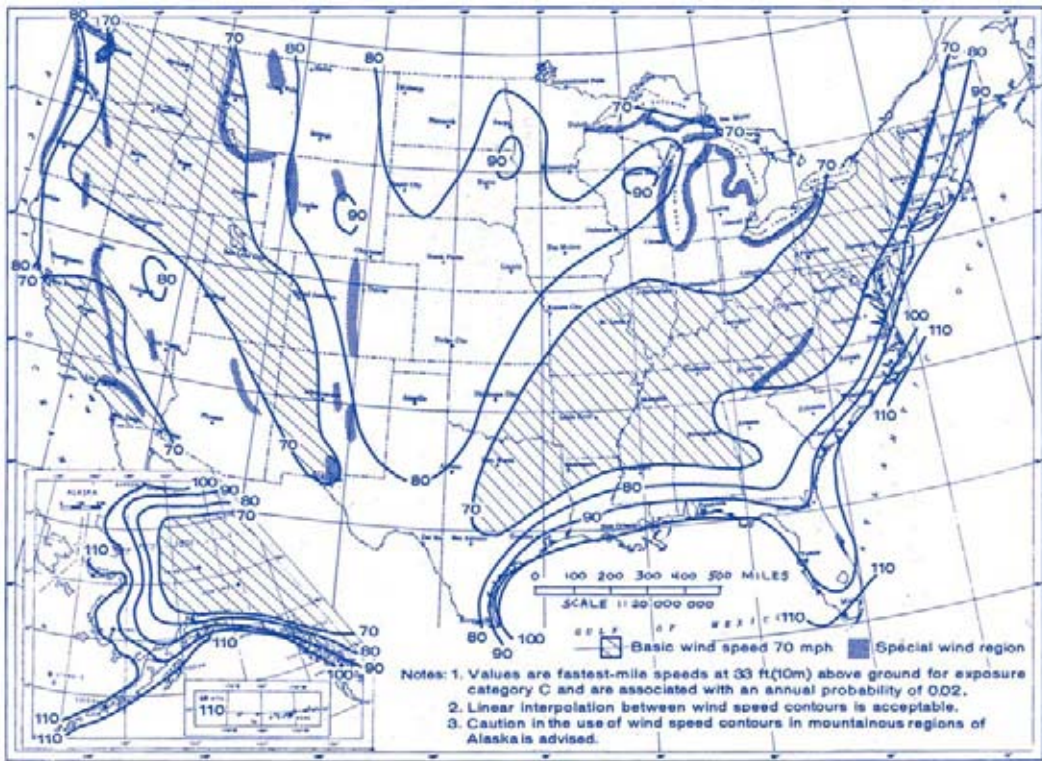

Figure 1. From American National Standard ANSI A58.1-1992.

The current 2003 International Building Code requires either that shingles be fastened by six nails properly placed in front of the seal line, or that a rated product be utilized on the roofs in wind regions rated at or above 110 mph. Shingle manufacturers now produce products that are rated between 60 and 130 miles per hour, based on a two-hour duration test. Many manufacturers comply with requirements of the American Society for Testing and Materials (ASTM International) and Underwriters Laboratories (UL) for impact and wind resistance. The selection of the products should include compliance with UL 2218: Impact Resistance of Prepared Roof Covering Materials (Class 4 is the highest impact-resistant classification). The use of this method of selection allows the consumer products that are designed and warranted for regions with high winds and hail conditions, but still require proper installation. This perfor-

mance-based approach means that the product protects the building to the performance standards of the rest of the selected structure and cladding.

Areas such as Colorado's Front Range

are clearly depicted as high wind regions in the Building Codes and ASCE 7 Guidelines. The local or state building departments can prescriptively mandate that high-wind requirements be specifically adopted. The lack of a specific mandate should never be reason for a contractor to fall short of properly installing products that can withstand the design wind-load requirements on a project. The components of the building must be properly selected and installed.

Note that the area shown in southern Colorado is west of the 105th Parallel. This map has an obvious flaw; the eastern down-slope hillside of the southern Colorado Front Range was not properly shown as a high wind area.

This error was corrected and indicated in the 1995 Standard. The Uniform Building Code published by the International Conference of Building Officials (ICBO) never corrected this error with the updated map. By publication of the

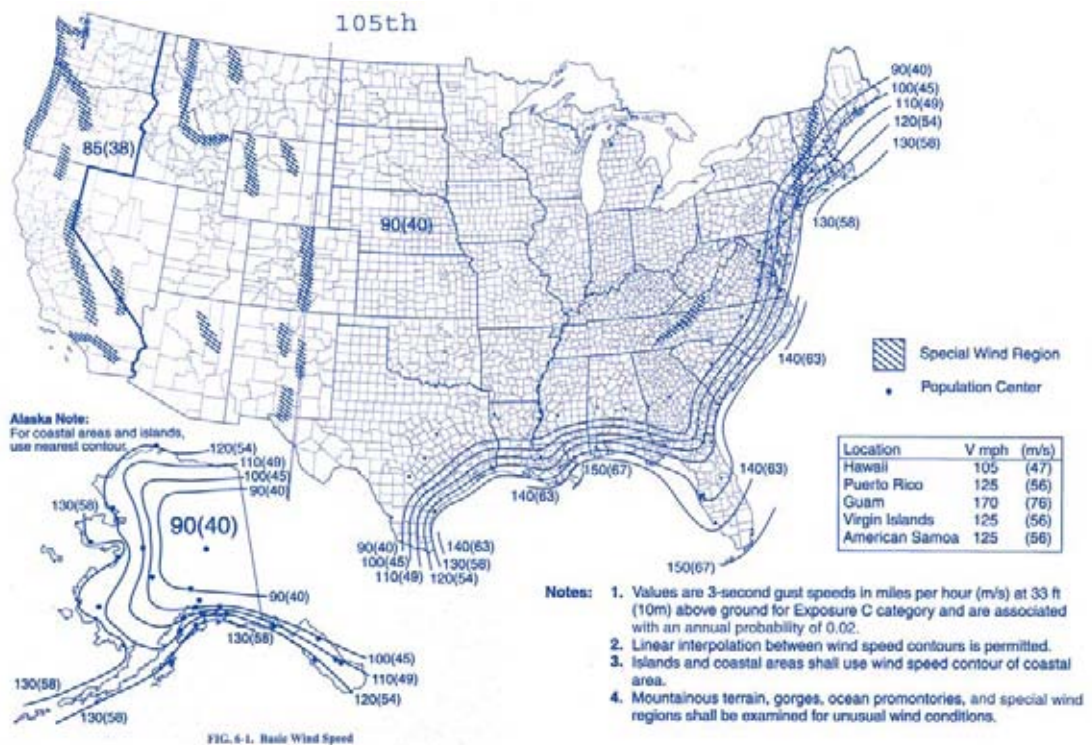

Figure 2. From ASCE Standard ANSI/ASCE 7-95, approved June 6, 1996.

International Residential Code and the International Building Code, the correct map was included (*Figure 2*). The map areas are unchanged from the 1995 ASCE document. However, common sense would dictate that the front range of Colorado, specifically parts of Douglas and El Paso Counties, should have been included and that the original map indicated the incorrect positioning of the wind zones.

According to the building codes and ASCE, the building needs to be designed for appropriate load requirements, including combinations of loads. The building's ele-

ments are required to resist the design loads. The intent of this performance requirement is that the elastically computed stresses produced in the assembled building are not exceeded. The serviceability of the products, as defined by code and the manufacturer's requirements, includes deflection, drift, vibration, and other deformations that would be adverse to the materials' performance. These requirements include self-straining forces such as temperature, moisture, creep, shrinkage, and the materials' inherent stress properties, typically bending and shear. The compo-

nents and claddings should be included in the design of the structure.

Wall and roof claddings, whether siding, stucco, stone, brick, single-ply, multi-ply, metal panel, or asphalt composition products, must remain on the building façade or roof during the application of the loads. In this case, the primary force of removal would be the wind load. The basic wind speed is defined either as the 3-second peak gust or the fastest mile. The design probability is that of an annual probability of equaled or exceeded value. The 0.02 annual probability would relate to the 50-year mean recurrence interval.

According to the Institute of Business and Home Safety (November of 1999), the Florida Building Commission (FBC) required that single-family homes have proper design for uplift. The only dissenting members were commissioners who represented the homebuilders industry. This requirement for uplift design is exceptional in that the products or systems installed on residential construction have similar requirements to commercial construction. Seeing as how wind forces do not care whether or not they are impacting a commercial or residential structure, good building design and installation practices should be followed to prevent damage.

When reviewing the wind map to determine product requirements, the designer, contractor, or developer should be selecting a product capable of resisting a 50-year recurrence storm. The recurrence interval is the 2 percent probability that the product will experience that event on any given year for a 50-year period. This is similar to designing floodways that withstand a 100- to 500-year recurrence interval or a 50-year recurrence snowstorm event. The code is clear that the building should be constructed both structurally and architecturally for the design recurrence interval.

In order to evaluate products for real-world requirements, the testing of shingles must consider both lift of the leading edges and the uplift of fasteners. According to the *FEMA Asphalt Shingle Roofing for High-Wind Regions, Recovery Advisory 2*, the following lists indicate the minimum recommended shingle requirements for a design wind speed of greater than 90 mph up to 120 mph, based on 3-second peak gust and a design wind speed of greater than 120 mph (ASTM D-3462 specifies a minimum fastener "pull-through" resistance of 20 pounds at 70° Fahrenheit). If a higher resistance is



RCI, Inc.
800-828-1902
www.rci-online.org



Photo 1. Overview of a building on the property, showing the loss of shingles.

A prescriptive code example of dealing with the issue of properly sealing the leading edges that are not automatically sealed includes such language as that adopted in the 1999 Pikes Peak Regional Building Code (Colorado Springs, Colorado) Section 16-2-103, CA, 8, Self-sealing Strip Shingles. It reads, "Installation of self-sealing strip shingles weighing less than 240 pounds per 100 square feet may be installed only during daylight saving time periods (April through October)."

Of course, even this prescriptive language requires that the applicator verify that the

desired, it must be specified, based on fastener pull-through resistance and bond strength (provided by the sealant strip).

Property: Fastener Pull-Through Resistance

- Design wind speed greater than 90 mph up to 120 mph: Minimum recommended – 25 pounds at 70° Fahrenheit.
- Design wind speed greater than 120 mph: Minimum recommended – 30 pounds.

Property: Bond Strength

- Design wind speed greater than 90 mph up to 120 mph: Minimum recommended – 12 pounds.
- Design wind speed greater than 120 mph: Minimum recommended – 17 pounds.

It should be noted that neither ASTM D225 nor D3462 specifies minimum bond strength. If minimum bond strength is desired, it must be specified in the design documents or the building code.

Prior to the current high wind requirements, the method of properly installing asphalt composition shingles was the application of six nails below the sealing strip. The Asphalt Roofing Manufacturer's Association (ARMA) and the National Roofing Contractors Association (NRCA) have clearly indicated this method in their application/installation manuals for over a decade. Many shingle manufacturers also indicate that "hand-tabbing" of the leading edge of the shingles should be employed, and special precautions should be taken during colder months, where the self-sealing tabs may not bond.

edges are sealing properly. The return visits may ultimately require that the applicator "hand-tab" the edges with asphaltic-based cement. It must be realized that the site conditions that caused uplift and sediment transport could result in seals that may never self-activate.

As an example of this condition, PIE reviewed a project in the same area and jurisdiction that had substantial shingle blow-off. It was determined that there were often two or three causes. The nails used were not sufficient in number to deal with the design events of the 50-year recurrence, or even the "prescriptive" 85-mph-exposure

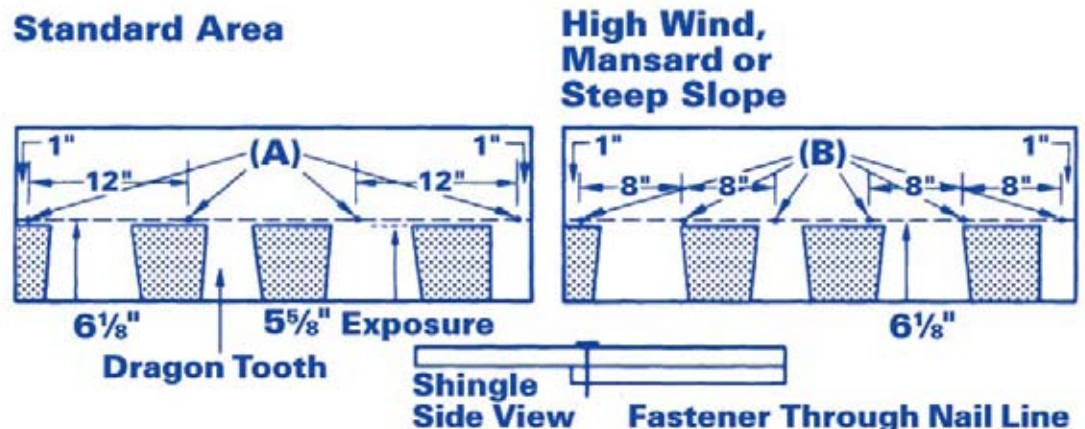

Figure 3: Manufacturer's installation instructions.

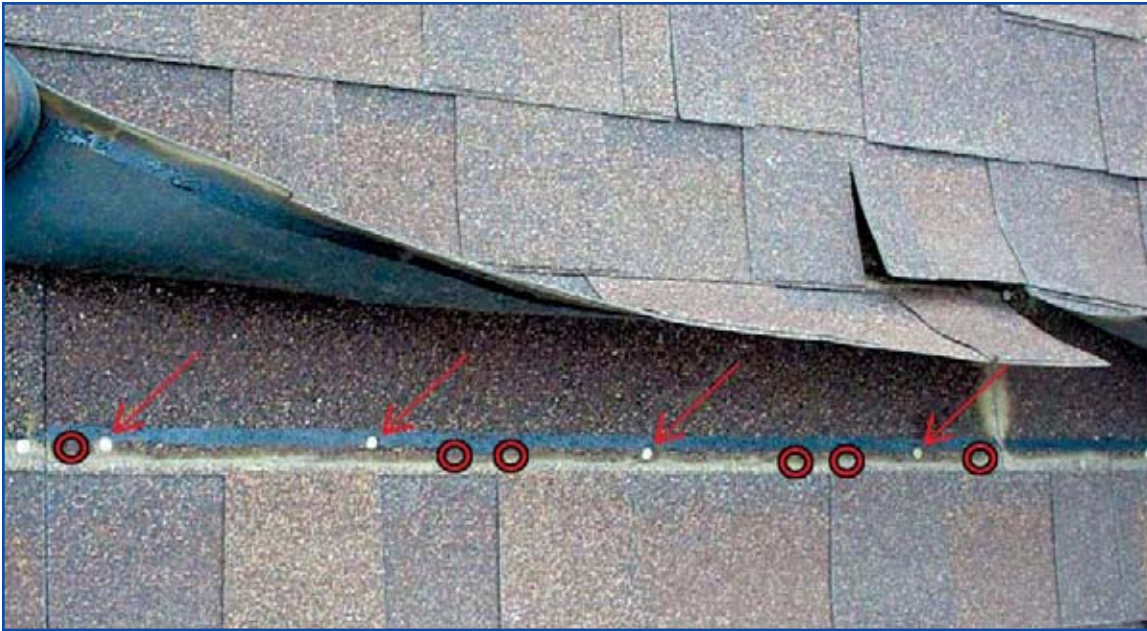

Photo 2: Discovered conditions on the buildings.

C wind event. The manufacturer only warranted the shingles to 60 miles per hour. According to the manufacturer's documents, "all shingles containing a strip of thermal sealing asphalt must be subjected to warm sunlight for several days before full

sealing will occur. Shingles installed in the fall or winter may not seal until the following spring. Shingles that do not receive direct sunlight or that are not exposed to adequate surface temperatures may never seal." The Limitations on Coverage include

intact to deal with the potential edge failure.

The nails used to secure the shingles were discovered to be improperly placed, and the shingle blow-offs propagated from many apparently unsealed edges. Photo 1 shows the patterns and large areas of blow-off (now replaced; see darker patched areas).

The installation instructions provided by the manufacturer showed the following requirement for high-wind areas.

It was discovered that on the roofs that experienced blow-off, the shingles had not been installed with either a proper four-nail or six-nail pattern. Photo 2 depicts the conditions found on many of the roofs. The red circles note where the nails should have been placed in a six-nail pattern. The shingles were also found to be improperly lapped with the corresponding shingles, and many seals were loose. The nails were placed too high on the shingle. This misinstallation results in a nail that penetrates through only one laminate of the shingle. It was determined that the nails were located too far inward from the edges. The product was rated by warranty to 60 miles per hour, Exposure B. This 60-mph-rating does not meet the building code's requirement for this specific area, defined by local code as 85 miles per hour.

The shingles are, therefore, not installed to the more stringent conditions for the high wind design requirements; and, in fact, the product chosen does not meet performance requirements of the building code.



RCI, Inc.
800-828-1902
www.rci-online.org

Regardless of actual findings by PIE, the manufacturer's representative stated the following in his report regarding this project, "Per our conversations at the subject property during our physical inspection of several buildings on May 28, 1999, I would like to reiterate that I observed normal and proper installation practices. The roofs are installed to the satisfaction of (Product Manufacturer) and are fully warranted as per our written warranty. Should you have any further questions, please do not hesitate to call me at the above number."

In PIE's opinion, this manufacturer's representative did not factually represent conditions that exist at this site. Not only were the nailing methods incorrect (number and placement), but there were instances of improper lapping and poor integration of roofing components, including flashings, sealants, sidewalls, chimneys, and the stucco systems.

The blow-offs occurred on almost every building at the site within the first five years of completion. This manufacturer's statement did not specifically address what it was warranting or the terms of the product warranty versus installation standards. The usual warranty is for the product only and has

nothing to do with overall installation. In fact, the warranty would not typically cover improperly installed product. The document, in PIE's opinion, which would then require a claim on the product, misleads the

reader to believe the product had no installation issues. In fact, no warranty claim against the manufacturer was undertaken, and rightfully so, as PIE found the installation of the shingles to have been improper.

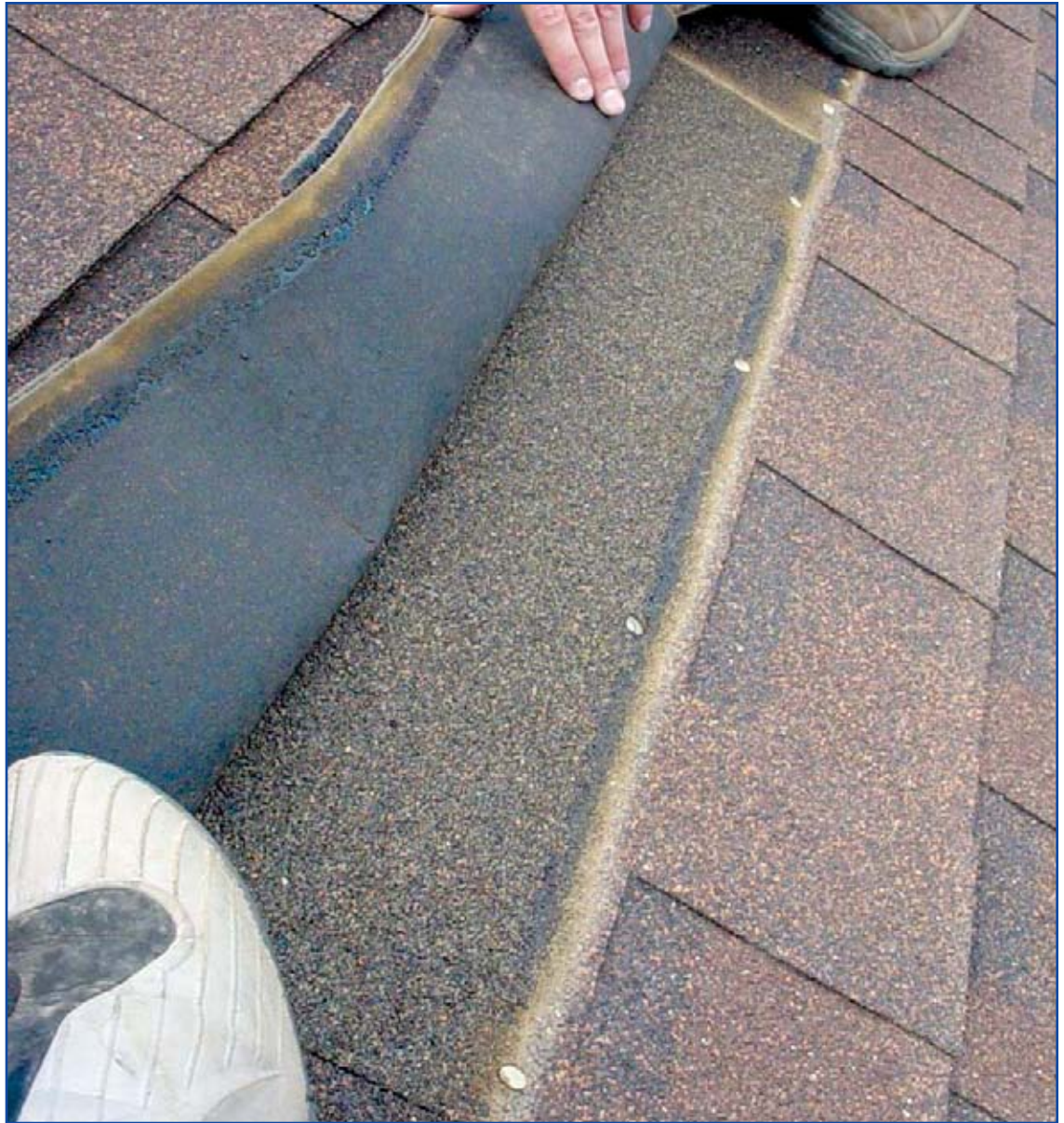

Photo 3: The nails are placed not only in the wrong locations, but also above the asphalt seal line, resulting in penetration of only one of the laminate shingle layers.



RCI, Inc.
800-828-1902
www.rci-online.org



RCI, Inc.
800-828-1902
www.rci-online.org

The manufacturer's representative may have opened another issue in the litigation process regarding the quality assurance role for the ultimate consumer. This is because the manufacturer's representative was providing service to the sub-contractor, not the developer or owner of the property.

The developer, contractor, engineer, or architect should specify and select products rated to the region, regardless of what someone else has "done for the last 30 years." Reliance on building code officials or other inspectors for quality will not guarantee proper installation of materials. The responsible parties will fall from the top downward, and only that department will be missing from the table to discuss why improper installation had been allowed.

Based on our experience with reviewing specifications and providing quality assurance work on similar projects, we believe that the roofing industry has risen above this original "below standard" approach. The industry is now providing products that are tested to perform in high-wind areas. These products must then be properly installed and integrated into other building envelope systems to ensure necessary per-

formance. Failure to comply with the installation instructions clearly violates most manufacturers' warranty terms. PIE notes that the product warranty does not apply to the installation methods or deal with cross-trade components such as stucco paper, lathe, and sidewall interfacing.

With proper products and adherence to good construction practices and design, the selected building components will perform their intended function. 

Edward Fronapfel, PE

Edward Fronapfel holds a Bachelor of Science degree in civil engineering, and a Master of Science in civil engineering with an emphasis on structural engineering. He is a Certified Level 2 Infrared Thermographer, and a Certified 3rd Party EIFS Inspector. Ed's background includes geo-hydrology, hydrology, hydraulics, civil engineering, structural engineering, and extensive work in construction forensics for building envelope sciences. Clients include construction, management, and insurance companies, attorneys, homeowners, and homeowner associations. Work has included deposition and expert witness testimony, mediations, and arbitrations. He is a registered engineer in the states of Colorado, North Dakota, Wyoming, New Mexico, and Nebraska. Ed is also a published writer in *The Investigative Engineer*, *The I-ENG-A Report*, *Inframation Proceedings Volumes 4, 5, and 6*, the *Colorado Claims Guide*, and *Building Integration Solutions*, ASCE and AEI.



Ed can be reached at efronafel@callpie.com, 303-552-0177, or 1-866-552-5246.