

# RETRACTABLE STADIUM ROOFS AND FLOORING

By Barton L. Riberich, SE

## Brief History of Kinetic Architecture in Stadia

Kinetic architectural elements have been integrated into stadia as far back as the days of the Roman Coliseum. The Romans incorporated retractable sunshades, elevator floors, and trapdoors into the Coliseum for the same reasons that we use kinetic architecture in modern stadia. These adjustable mechanized structures adapt to changes in climate, need, or purpose and provide awe-inspiring, elegant solutions to what appear to be nearly impossible engineering challenges. Today there are over 30 modern sports venues around the world that incorporate retractable roofs and other large mechanized structural elements. These venues are still somewhat novel, and they generally evoke a reaction of awe and amazement as they gracefully translate and rotate building elements weighing thousands of tons.

Since the days of the Roman Coliseum, popularization of retractable roof stadiums has been somewhat slow. This is illustrated by the fact that over two-thirds of the retractable roof sports venues that are in operation around the world today have been built and put into operation within the last ten years. During the same ten-year period, only a few fixed-roof stadiums were designed and built, further illustrating the increasing popularity of retractable-roof stadiums worldwide. Furthermore, in addition to retractable roofs, the integration of other

large mechanized elements into sports venues has become more common in recent years. There are now a few retractable playing surfaces in service at soccer and American football stadiums around the world. Large mechanized walls, mechanized seating sections, and mechanized entertainment features are becoming more common in new sports venue construction as well.

Why has the integration of large mechanized elements into modern stadia been so slow in coming, and why is it so popular now? Many factors contributed to the scarcity of large mechanized elements in the sports venues of decades past. These include the following:

- The design, manufacturing, and installation of large mechanized elements do not fit seamlessly into the conventional core competencies of the sports venue design and construction industry. There are no design standards, building codes, estimating guides, or standard specification sections available to help address the most challenging aspects of planning, designing, and building a retractable-roof facility.
- Some of the first few attempts at incorporating retractable roofs into modern sports venues were plagued with significant cost overruns, serious schedule delays, leaky facilities, and mechanically unreliable sys-

tems. These projects were considered problematic at best and created a general feeling within the sports venue construction industry that retractable roofs and other large mechanized features were costly and potentially risky.

- Patrons' needs, facility operating requirements, and markets have changed over the years. In decades past, the cost benefits associated with retractable roofs were not as great as they are today, and the benefits that did exist were not fully recognized until some successful operating examples were in service for a period of time.

Many of these historical barriers that had held back the widespread construction of retractable-roof sports venues have since disappeared or been broken down by the pioneers of retractable roof stadia. These trailblazing owners, operators, architects, engineers, and constructors led the way past some of those initial setbacks to construct and operate some of the most successful and highly revered sports venues in the world. Design and construction teams learned how to effectively incorporate mechanization design and supply into their planning, designing, and constructing processes. Technology has improved to make operating systems more cost-effective, easier to

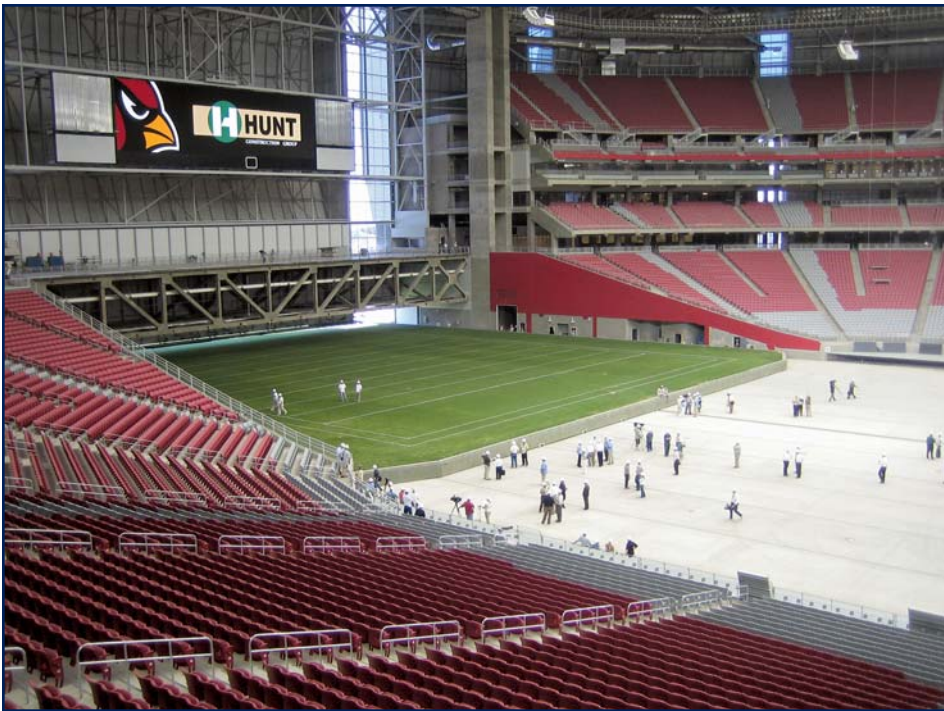

Figures 1A and 1B – University of Phoenix Retractable Roof and Field

operate, and more operationally reliable. In North America, the lessons learned from some of the problems experienced on those initial attempts have been taken to heart such that the last several retractable-roof stadiums constructed have been delivered on budget and on schedule and have been put into service with nearly 100-percent operational reliability from opening day forward. A more detailed discussion of the lessons learned and methodologies proven to be successful will follow in later sections of this article.

The increased desire of owners and operators to integrate large mechanized features into stadia has been the direct result of the operating success of those first attempts. Even some of those initial projects that were difficult and costly to build or that suffered through initial operational problems have persevered to become operationally reliable systems that produce increased revenues and operational flexibility for their owners. The Association for Retractable Roof Operators Worldwide (ARROW) has published a paper titled “Retractable Roofs in Sports Stadiums: Money Well Spent” that outlines the operational advantages and increased revenues associated with retractable-roof sports facilities.

The Milwaukee Brewers increased their attendance at ball games by nearly 50 percent during the first six years of operation of Miller Park when compared to the previous six years of operation at its former ballpark. Attendance increased even though the

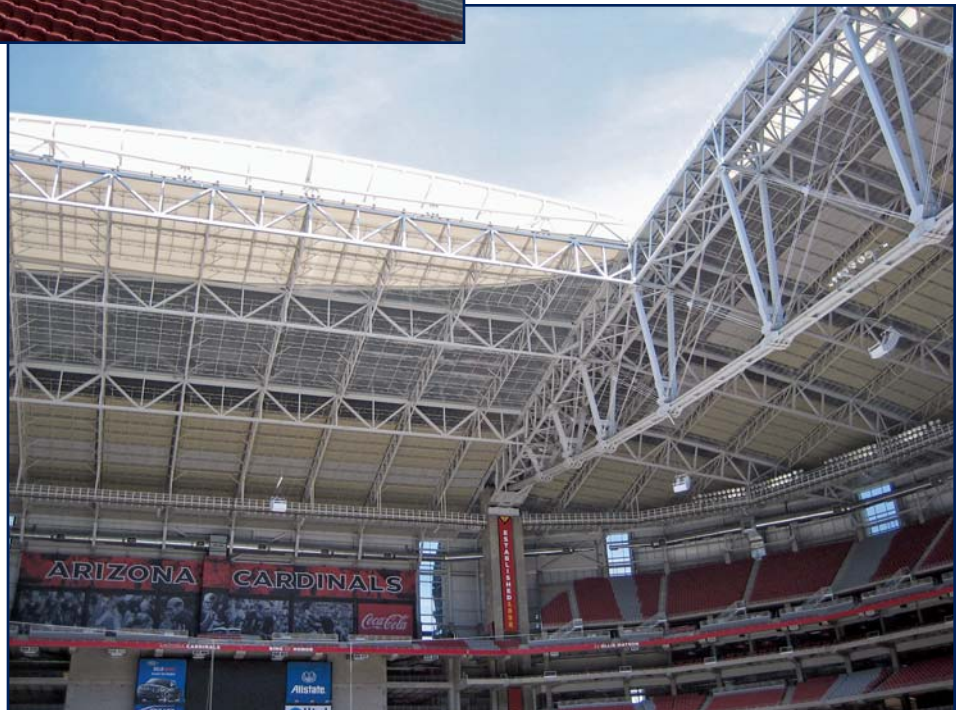

team’s winning percentage was lower at the new ballpark. Miller Park has an impressive retractable roof and a set of 70-ft-tall operable outfield walls. Mike Brockman, facilities manager at Miller Park, says, “We think that increased fan comfort and guarantee of an event is a big part of this growth. We have hosted over 600 events without a weather-related delay or cancellation over six years.”

The University of Phoenix Stadium, in Glendale, Arizona, is a publicly owned and operated multipurpose facility and the home of the Arizona Cardinals. The structure opened in the summer of 2006 and incorporates not only a retractable roof, but

also the first retractable playing surface in the National Football League (NFL). This facility has become the benchmark for multipurpose facilities. It is able to host an NFL game on a natural-grass playing surface, and then, immediately following the completion of the game, the 19-million-lb playing surface is driven outside to expose a completely functional trade-show floor. This operational flexibility allows much more utilization of the facility and thus produces increased revenues. Ted Ferris, CEO of the Arizona Tourism and Sports Authority, states, “If you want your stadium to be truly multipurpose, then you must invest in these mechanized systems to make the

facility work for you.” (See Figure 1A and 1B.)

The improvements in the design and construction of large mechanized elements, coupled with a better understanding of the operational benefits associated with these features, have fueled the most recent demand for the use of retractable roofs and other large mechanized structural elements in stadia. Now it is the job of the engineering community to meet this demand by providing safe, cost-effective, and reliable systems.

### Delivering an Architectural Icon and an Engineering Feat

Throughout history, civil engineers have successfully designed and constructed large mechanized structures such as mechanized bridges and water-controlled structures, but the task of designing and constructing multimillion-pound retractable roofs, operable glass walls, and retractable playing fields is outside of the norm for most of us. So what should be done when challenged with such endeavors? All available precedents, historical data, operating examples,

technical guidance, and personal experiences should be drawn upon. The stadium projects that have successfully incorporated large mechanized elements can provide a set of best practices. Some of those best practices are:

- The owners, operators, architects, structural engineers, mechanization consultants, building officials, and constructors should work together as early as possible to define design criteria and operating parameters of the mechanized elements. Although there is scant building code guidance on these matters, there are now numerous historical precedents and several design firms experienced in these processes. This effort produces important basic design criteria such as operating times (typically 5 to 20 minutes), operating wind speeds (typically 50 mph), stopping times or deceleration requirements (varies depending on safety considerations and structural capabilities), life-cycle duty (varies depending on intended usage), etc.
- The mechanization design and all of its implications must be an integral part of design from the beginning of schematic design forward. It could be catastrophic to assume that a performance specification could be written and that the drive and control systems could be integrated into the structure as a design/build element during the construction phase. Instead, the mechanization consultant should be included on the design team from day one of design.
- The initial roof weight and operating load estimates should be conservative. Contingencies on operating- and static-condition loads should be included throughout design of the mechanical systems; 20 percent should be included in early design and 10 percent toward the end of the design phase.
- A holistic-design approach should be taken. The structural engineer must have an intimate understanding of the control sequences, the braking characteristics, and the forces imposed on the structure by the drive system under all conditions. The structural engineer should expect the number of loading conditions that must be evaluated to be several times greater than what

# KEEP ON TOP OF ROOFING, WATERPROOFING, AND EXTERIOR WALL TECHNOLOGY

with  
**Interface**  
the technical journal of RCI, Inc.

A monthly\* publication from the industry's experts, featuring the latest technical information:

- avoiding trapped moisture
- energy-efficient roof designs
- sustainable building products
- roof warranties
- protected membrane systems
- steep roofs vs. low-slope roofs
- bituminous roof systems
- cold-applied roof systems



- insulating cellular concrete
- wind resistance and more

ONLY  
**\$90**  
PER YEAR (US)  
11 ISSUES\*

**Subscribe today!**

Name \_\_\_\_\_  
 Company \_\_\_\_\_  
 Address \_\_\_\_\_  
 City \_\_\_\_\_ State \_\_\_\_\_ ZIP \_\_\_\_\_  
 Phone \_\_\_\_\_ E-mail \_\_\_\_\_

Amount Enclosed \$ \_\_\_\_\_  
 Check (payable to RCI)    Visa    Mastercard    American Express  
 Card No. \_\_\_\_\_ Exp. Date \_\_\_\_\_  
 Name on Card \_\_\_\_\_  
 Signature \_\_\_\_\_

MAIL OR FAX TO:

\*RCI publishes 11 issues of Interface a year



**RCI, Inc.**  
 1500 Sunday Drive, Suite 204, Raleigh, NC 27607-5151  
 Phone: 800-828-1902 • Fax: 919-859-1328 • [www.rci-online.org](http://www.rci-online.org)

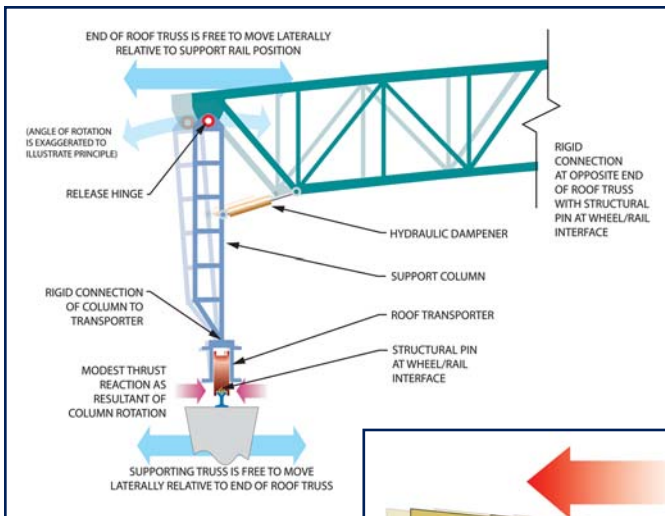

Figures 2A, 2B, and 2C – Thrust release mechanisms.

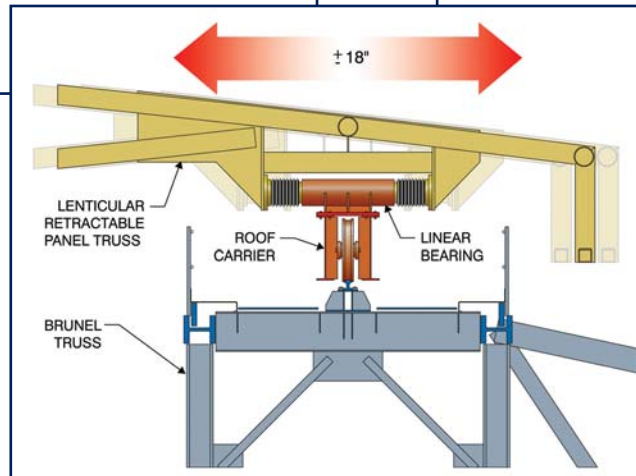
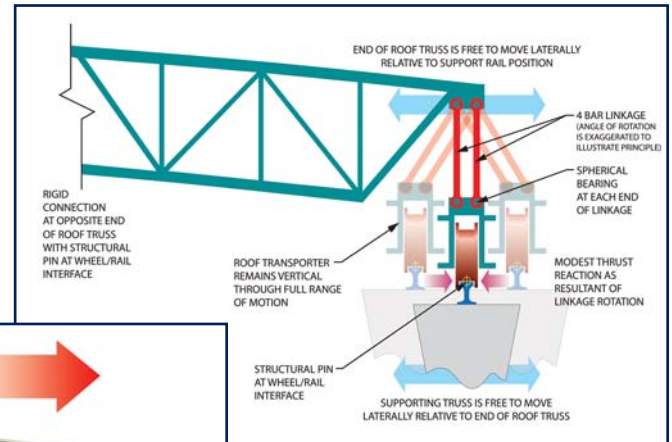

would be expected for a static structure. The mechanization consultant must have an intimate understanding of the stiffness of the structure, all externally applied loads, deflections under load, control sequences, fabrication tolerances, and construction tolerances, as these things affect drive loads and wheel loads. The controls engineer must have a complete understanding of the behavior of both the structural and mechanical systems.

- Wherever practical, a delivery method that provides a single point of responsibility for the successful design and delivery of the mechanized element should be used. This is often accomplished with some form of design/build contract for the mechanized element, where the contractor is selected early in the design process and the mechanization design team is included on the building design team. A clear scope

of work should be defined to delineate areas of responsibility in detail for all parties involved.

- Thrust release mechanisms should be integrated into retractable roof stadiums to minimize the need for tight construction tolerances and eliminate unnecessarily punishing thrust loads on the mechanization components. In general, moving-part components cost more than static components. Therefore, it is usually cost-effective to minimize the loads directed through moving parts using built-in hinges, linkages, or slide bearings such that the retractable roof span is a determinant structure. (See *Figures 2A, 2B,*

and 2C.)

- The effects of the changing support conditions as the retractable roof structure moves through its full range of motion over its supporting structure should be evaluated. This evaluation includes effects of support structure construction tolerances, structural displacements, potential differential foundation settlements, and thermal movements. Either the retractable-roof structure should be flexible enough to accommodate the anticipated variations in support geometry without overstressing the structure or its supporting wheels, or a suspension system for the retractable-roof structure and its supporting wheels should be provided. (See *Figures 3A, 3B, and 3C.*)
- Considerations for weather sealing must be incorporated into the design from the very beginning. Such planning should include a reasonable cost budget for these specialty systems. The seal design must account for relative movements of long span structures, construction



tolerances, stopping-position tolerances, required clearances, and the effects of externally applied loads. In addition, access must be provided

for inspection, repair, and replacement of seals. (See Figure 4.)

- A reasonable means must be provided to inspect, maintain, repair, and

replace every mechanical and electrical system component. Jacking points or temporary strut connections should be included to provide a secondary load path in order to facilitate removal of mechanical components. A means to hoist and handle replacement parts is also required, along with safe and reasonably convenient personnel access and working space for operation, inspection, maintenance, repair, and replacement.

- Time and money must be budgeted to test everything reasonably possible, using proven technologies whenever feasible. Prototype tests should be executed on new technologies and applications for function, life-cycle performance, and structural integrity. Every manufactured mechanical and electrical component is potentially flawed and should be tested before it is put into service. It is much less expensive to find and correct a problem in the shop than it is to repair or replace components when they are supporting a multimillion-pound structure.
- Float is required in the manufacturing schedule to allow for recovery from schedule setbacks such as delinquent vendor delivery or replacement of flawed or damaged components. Because these systems are custom-designed and -manufactured electromechanical assemblies with thousands of components, it is almost inevitable that some will be delivered later than expected and some will be delivered with flaws. Having a Plan B is a must.
- Where practical, a small number of spare manufacturing parts should be included in the budget and ordered to keep manufacturing on schedule in the event that a single part is flawed or damaged during shipment, storage, handling, or assembly.
- Every step of manufacturing should be verified. It is likely that the thousands of components for the system will be manufactured and provided by a multitude of vendors. For custom-designed and -manufactured components, the design team should provide manufacturing quality-assurance check sheets to identify critical dimensions and the mini-

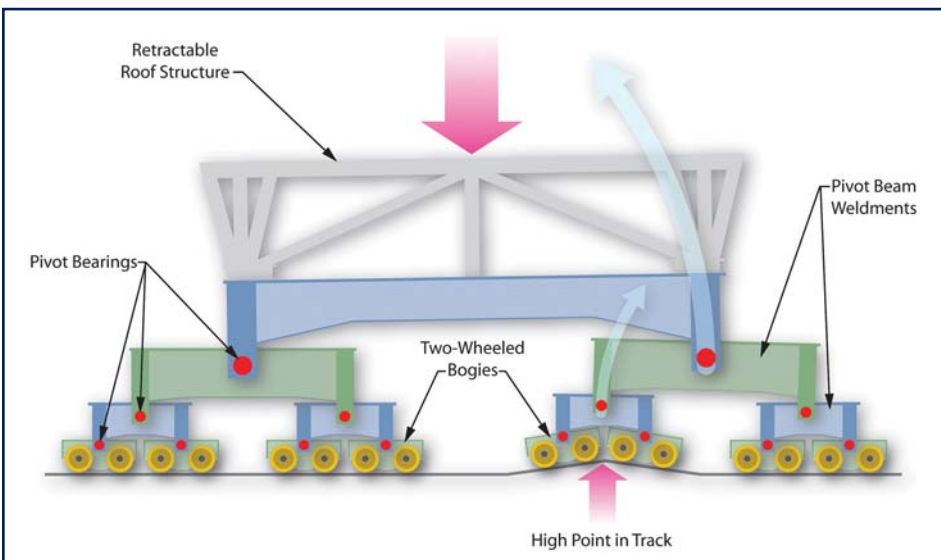
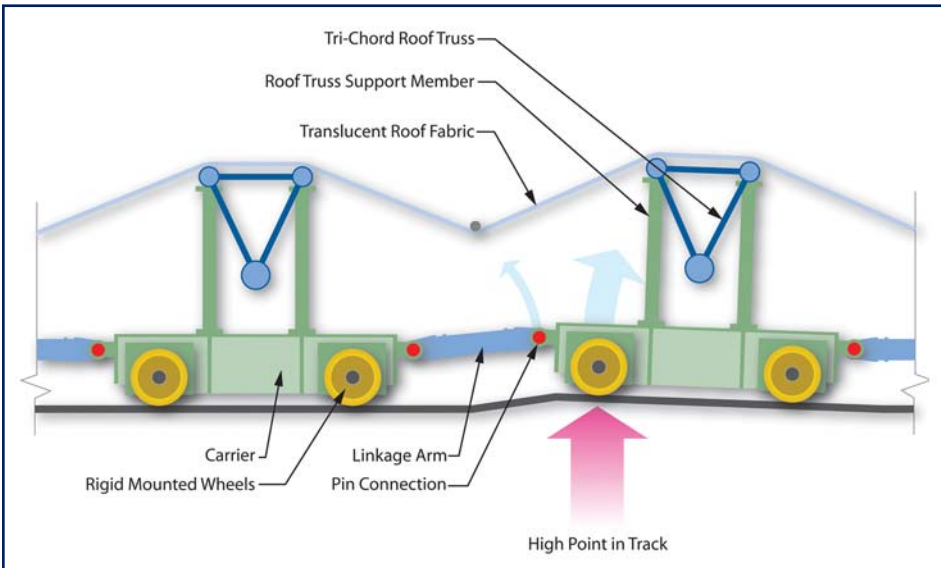
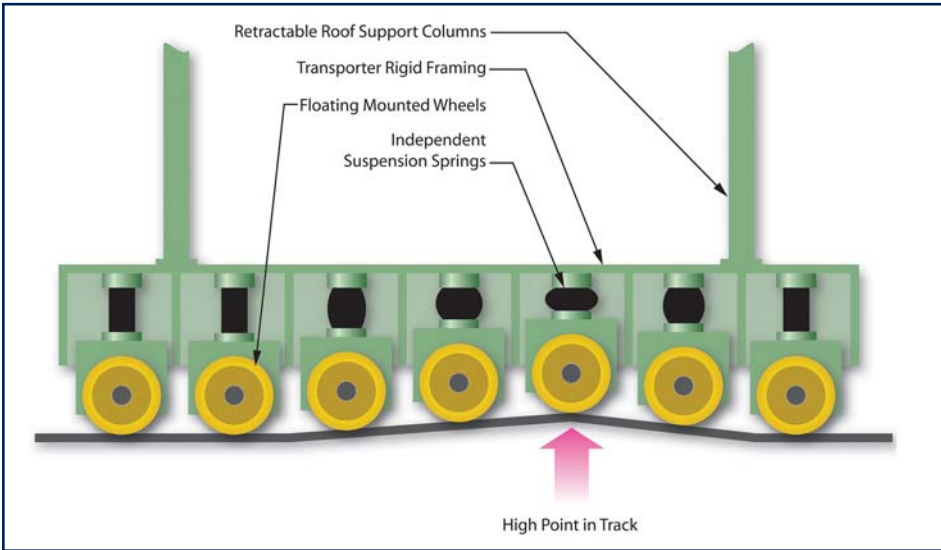

Figures 3A, 3B, and 3C – Wheel suspensions and load distribution.

imum quality-assurance requirements. Where practical, the design engineer should audit the manufacturers' quality-assurance process and inspect the first manufactured article of each component. When manufactured parts are received at assembly facilities, they should be immediately checked for damage and inspected for compliance with the specified requirements. Test fit assemblies for components should be performed as early as possible as a further verification of component adequacy.

- The design engineers should participate in the first article assembly of all assemblies and subassemblies. Wherever possible, the operation and performance of completed assemblies should be tested in the shop by the design engineer.
- The budget should include cost contingencies for rework and surprises in both the manufacturing and construction phases of the project. A 15- to 20-percent contingency should be carried before the design is completed, and a 10-percent con-

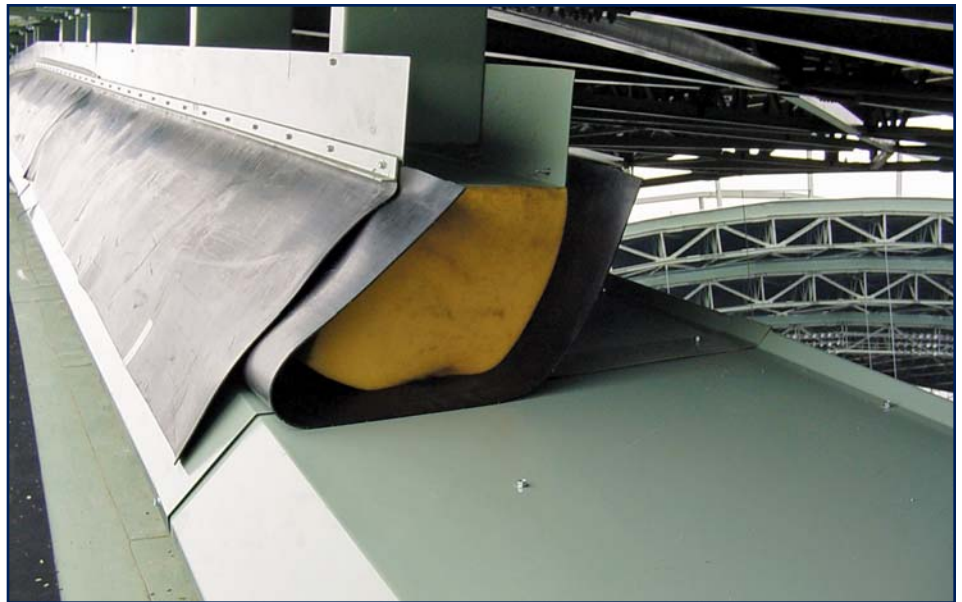

Figure 4 - Miller Park Bulb Seals.

tendency should be carried after design is completed. Regardless of the precautions taken, unanticipated costs will inevitably arise during the process of delivering these large and complex custom-designed and -manufactured systems.

- Adequate schedule time must be provided for the system supplier to execute a safe and deliberate regimen of start-up and testing sequences in order to verify the performance of each feature of the control system and the safety system and of



**Easy to Install**

## Turn roof tops into beautiful deck areas

**The PAVE-EL® Pedestal System**

- Transforms flat roofs into attractive, maintenance-free, paver stone terraces.
- Elevates paver stones for perfect drainage.
- Levels paver stones and ensures their uniform spacing for an ideal roof terrace surface.
- A perfect solution for laying mechanical walkways for use by maintenance personnel.
- Ideal for laying paver walkways in roof gardens.



PAVE-EL®

ENVIROSPEC INCORPORATED

716-689-8548 • [www.envirospecinc.com](http://www.envirospecinc.com)

# HOW DOES YOUR RETRO-FITNESS MEASURE UP?



**Certified and Tested  
ROOF HUGGERS are the  
BEST WAY to REROOF  
your Old Metal Roof!**

No Need to tear off that old roof!  
Fits Over Any Panel Profile. Pre-punched holes for FAST Installation!! 10' lengths, 16ga., G-90, 50ksi Structural Grade Steel  
ADD insulation, heat recovery, or solar generation for even greater value.

FLORIDA PRODUCT APPROVED

-ROOF HUGGER-™



Reroofing The RIGHT Way!

800-771-1711 Or fax: 877-202-2254  
[www.roofhugger.com](http://www.roofhugger.com)

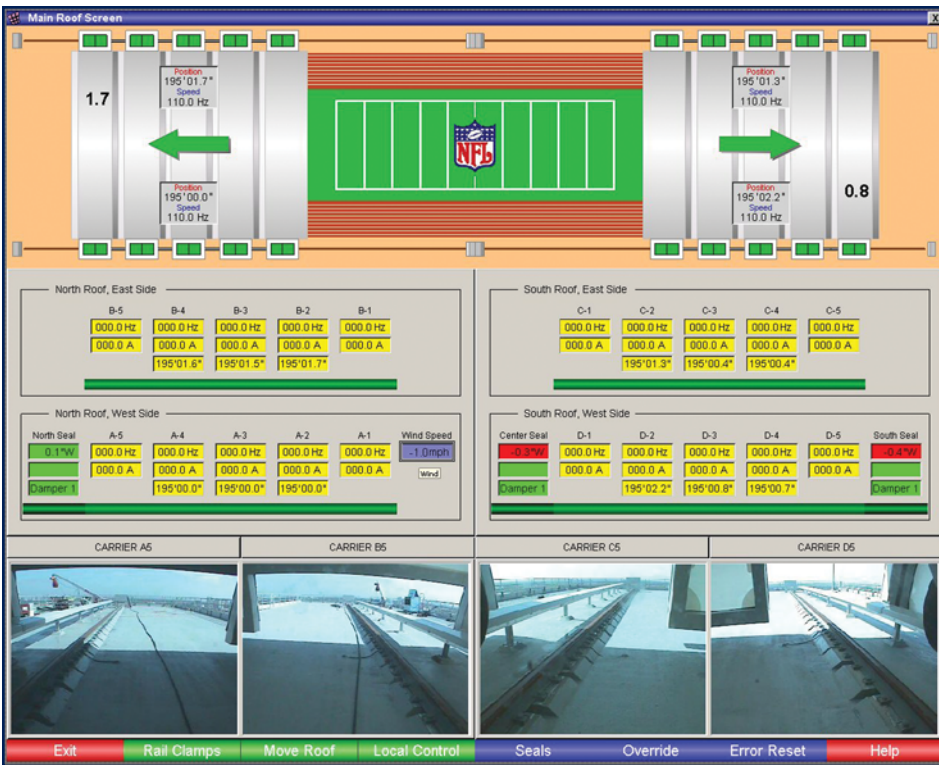

Figure 5 – Reliant stadium control screen.

each mechanical component. Two to three months should be allowed for the start-up and commissioning of retractable-roof stadiums. The roof should be completed, and the supplier must have free rein to operate the roof during this period. (In other words, other trades should not be scheduled to work on the roof during this period.) Regardless of the precautions taken, this process normally results in some small control-program changes and mechanical adjustments. Prior to handing the system over to the owner, the supplier needs time to make required changes and to identify and replace any components that are subject to “infant mortality.” This start-up and commissioning period is critical to a smooth and success-

ful handover to the owner, and the owner’s operator should participate with the supplier in much of this process as an opportunity to learn about the system and gain experi-

- ence in its operation.
- The project should include a modern control system with on-screen status indicators, diagnostics, and troubleshooting. Often, these systems have hundreds or thousands of electromechanical components located at remote positions spread out over several acres. If a single sensor or component fails, the control system must tell the operator where the failure is and how to correct it. (See Figure 5.)
- The control system should be designed and supplied to allow online, real-time technical support from the supplier’s control engineers at remote locations. The system should be supplied such that a technician from a remote location can observe the same operating screen as the operator on a real-time basis and provide technical support and troubleshooting support via telephone.
- As much as practical, drive systems should be designed with operational redundancy. Higher operational reliability can be achieved with systems that have a multitude of small motors and that allow for one or two

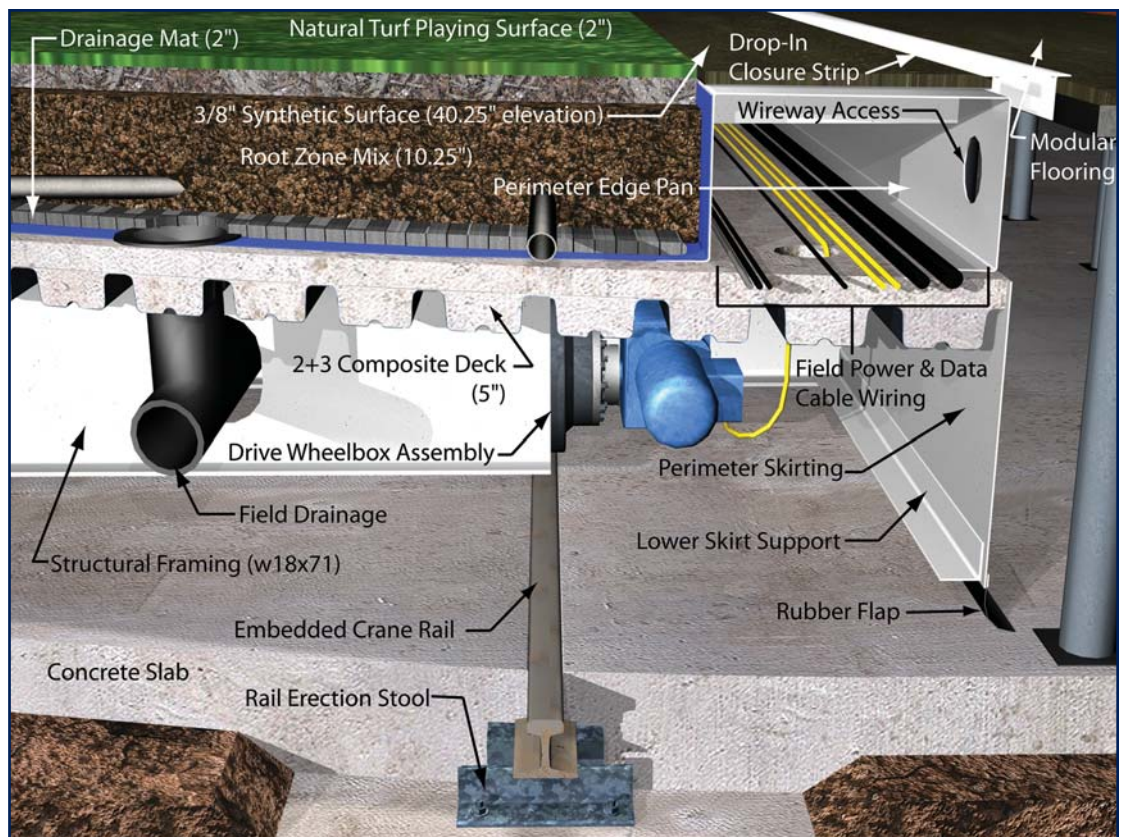

Figure 6 – University of Phoenix retractable field cross-section at edge.

motors to fail without rendering the system inoperable rather than having a single large motor. The smaller drive components can also be much easier to replace than larger components. As an example, the University of Phoenix retractable field incorporates a total of 500 steel wheels. Seventy-six of the perimeter wheels are driven by one-horsepower motors. Two motors on each side of the field can fail, and the system will still remain operational. (See *Figure 6*.)

- Turnover procedures and acceptance testing criteria should be identified as early in the project as possible so that all parties understand how the job will end before it becomes an issue.
- The design engineers should prepare training materials for the owner who provides the operators and maintenance staff with all appropriate design background, system behaviors, safety considerations, operating information, and maintenance instructions. The supplier should provide an initial training

program and leave behind training documentation for the owner to use for training subsequent generations of operators and maintenance staff.

- Clear, complete, user-friendly operation and maintenance manuals are an essential part of the delivery package.
- A budget should be included to provide a reasonable spare-parts inventory as part of the supply contract. Many of the system components are custom-manufactured parts with very long production lead times. If a component were to fail with no replacement spare in stock, it might render the system inoperable for several weeks. Also, it is more cost-effective to provide spares of custom-manufactured components during the original production run of the components as opposed to buying one or two copies at the end of the job.
- Where practical, the owner should be provided with any special tools that are required to operate, maintain, or repair the system.
- For large, complex systems such as

# BUILDING ENVELOPE KNOWLEDGE ASSESSMENT

Test your knowledge of building envelope consulting with the following questions developed by Donald E. Bush, Sr., RRC, FRCI, PE, chairman of RCI's RRC Examination Development Subcommittee.

1. **Durability of design and materials is mandatory with below-grade enclosure systems. Unlike some other building components that are designed and constructed to be replaced several times within the overall building service life, below-grade systems need to be built to what longevity standard?**
2. **What major elements typically comprise below-grade enclosures?**
3. **The performance of the below-grade enclosure system is influenced by the design and construction process. What three phases represent the design and construction process?**
4. **What are the four types of waterproofing membranes?**
5. **Drainage pipe at the perimeter of a foundation wall should be surrounded by free-drainage granular materials that are wrapped in filter fabric to prevent fines from filling in the porous spaces of the granular material. How much slope should be provided for the drainage pipe?**
6. **What is the first consideration required of the designer of a below-grade waterproofing system?**

Answers on page 20

## RCI 2009 DOCUMENT COMPETITION

### Now Easier and More Rewarding

In addition to the traditional winners' plaques and *Interface* publicity, the 2009 Document Competition Committee will award cash vouchers to nine winners in three categories:

#### LARGE PROJECT | SMALL PROJECT | REPORT

1 <sup>st</sup> Place winners .....	300 RCI Dollars
2 <sup>nd</sup> Place winners .....	150 RCI Dollars
3 <sup>rd</sup> Place winners .....	50 RCI Dollars

RCI Dollars will be redeemable for any product or service provided by RCI or the RCI Foundation. RCI Dollars are redeemable by the award winner or by anyone specifically designated by the award winner. Use your winnings for yourself or to help a friend or colleague buy a reference book or attend a seminar.



See What it Takes to Get Involved

[www.rci-online.org/document-competition.html](http://www.rci-online.org/document-competition.html)

RCI, Inc. 800-828-1902

# BUILDING ENVELOPE KNOWLEDGE ASSESSMENT

Answers to questions from page 19:

1. The approximate overall service life of the structure.
2. Foundation walls, floor slabs, and tunnels/vaults.
3. A. Investigation phase.  
B. Design phase.  
C. Construction administration phase.
4. A. Cementitious systems.  
B. Fluid-applied systems.  
C. Sheet membrane systems.  
D. Bentonite clays.
5. The drainage pipe should have a slope of at least 0.5%, but preferably of 1.0%.
6. Whether to use a positive- or negative-side waterproofing system.

REFERENCES:  
*Whole Building Design Guide (WBDG)*



Figure 7 – Cowboys Stadium retractable roof and operable end-zone walls being constructed.

stadium retractable roofs, the system supplier should budget for and provide the first-year maintenance, first-year warranty, and full-time, on-site technical assistance to the owner for some period of time (first season of operation) as a transition period for the owner to take over the system. This provides for a smooth turnover and a happy owner.

- Operation and maintenance costs should be included in the budget. In order to ensure reliable operation of any mechanized system, the owner must operate and maintain the system in accordance with the designer's requirements.

The use of these best practices, combined with teamwork, good engineering practices, and attention to detail have produced many trouble-free sports-venue projects that incorporate kinetic architecture. These successful projects have laid a solid foundation for the future of kinetic architecture in stadia.

#### It Won't Get Any Easier

The success of these projects, combined with an increased demand for functional flexibility and architectural significance, is resulting in owners and architects demanding an increasingly challenging mix of new and complex motions, shapes, and materials for the mechanized elements of stadia. For

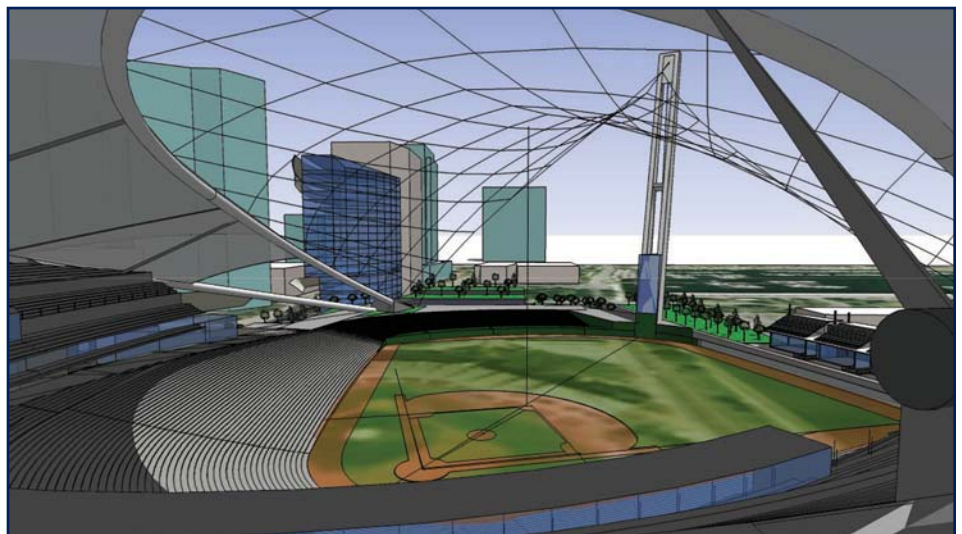

Figure 8 – Devil Rays ballpark concept.

example, the new Cowboys Stadium, set to open in 2009, incorporates a retractable roof that climbs a 24-degree slope on an arched rail and the world's tallest (125-ft) moving glass-wall panels. (See *Figure 7*.)

A recent proposal in Asia called for a ballpark roof that opens like flower petals with mechanized roof elements having cantilevered spans of 200 to 300 ft. The Devil Rays have recently unveiled plans for a new MLB ballpark in St. Petersburg, FL. (See *Figure 8*.) This design calls for several acres of fabric to be deployed and tensioned over a cable net structure in the event of rain. When not in use, this fabric roof is collapsed and stored under the inboard edge of the sunscreen structure that covers the seating area.

These design challenges call for a variety of new and innovative materials, structural systems, and mechanization methodologies. The keys to the success of integrating large mechanized components into these future stadiums will be much like

those of the past. Proven methodologies and technologies should be used when possible. When the design calls for something new and innovative, ample computer modeling/analysis, reduced-scale modeling, and full-scale prototype testing is imperative in order to validate design concepts and theo-

ries as they develop. The limits of this kinetic-architecture revolution are bounded only by the vision of the owners, the creativity of their architects, and the technical innovativeness of the engineers and constructors who bring these architectural icons to life.



### Bart Riberich, SE

Bart Riberich, SE, president of Uni-Systems, holds an MS in civil engineering and is a professional structural engineer in several states. He worked for two of the world's most respected engineering firms, Fluor Daniel and Black & Veatch, before joining Uni-Systems in 1994. Bart invented the patented torque tube truss system, which allows eccentric or torsional loading and is a key component of the Uni-Dock system. The torque tube truss allows the Uni-Dock structure to be offset away from the aircraft for maintenance while accommodating eccentric loads from decks fully extended to the aircraft surface. His innovative solutions to mechanizing large structures are fundamental to the success of each Uni-Systems project. Bart is also the coinventor of various other patents pertaining to mechanized features in a variety of building types and in aircraft maintenance docking equipment.



## PRESERVATION TRADES NETWORK TO HOLD SYMPOSIUM AND WORKSHOP

The 13th annual International Preservation Trades Workshop (IPTW) will be held by the Preservation Trades Network (PTN) August 25-29, 2009, in Leadville, CO, in partnership with the Colorado Mountain College Historic Preservation program. The 3rd International Trades Education Symposium will be held in conjunction with IPTW 2009.

IPTW is the only annual event in North America that brings the foremost practitioners of the traditional trades together in a single venue dedicated to sharing the skills and knowledge of all of the traditional trades through interactive, hands-on demonstrations and educational sessions. Since 1997, masons, timber framers, carpenters, painters, plasterers, roofers, metal workers, and practitioners of other traditional trades have come together with tools in hand to share their knowledge and demonstrate their skills at the annual "gathering of the trades." The IPTW is an interdisciplinary event designed to attract participants of many backgrounds, ages, and skill levels, including tradespeople, contractors, architects, engineers, conservators, educators, preservationists, students, and interested members of the public.

Workshops, "hands-on" demonstrations of preservation techniques, and symposium sessions will take place at the Colorado Mountain College Timberline Campus and the Hayden Ranch, an intact example of a high-country ranch and agricultural operation that operated from 1872 to 1947. Colorado Mountain College purchased the ranch for use as a laboratory, woodworking shop, and classroom space for students in the preservation trades program, and it promises to be a remarkable venue for IPTW-ITES events.

PTN is a 501(c)3 nonprofit membership organization founded to provide education, networking, and outreach for the traditional building trades. PTN was established on the principle that conservation of the built environment is fundamentally dependent on the work of skilled people in all of the traditional building trades who preserve, maintain, and restore historic buildings and build architectural heritage for the future.

For more information, visit [www.iptw.org](http://www.iptw.org).