

ROOFTOP EQUIPMENT SUPPORTS

By Karl A. Schaack, RRC, PE

Rooftops have commonly been used as a haven for the installation of various pieces of equipment with the mentality, “We have nowhere else to put them,” or “Let’s just put it up on the roof,” with very little thought or concern with the overall possible impact they could have on the service life or performance of the roof. A variety of items installed on roofs commonly include but are not limited to the following: HVAC equipment, communication equipment, packaged units, compressors, ducting, antennae, satellite dishes, security cameras, lighting assemblies, and a variety of associated piping and cabling. These items, how they are supported, and the improper installation of said items can have a significant effect on the performance of a roof system. See *Figure 1*.

There are generally three different methods for supporting the various items, including: 1) flashed curbs, 2) flashed steel supports, and 3) nonpenetrating supports. The NRCA-recommended details for supporting rooftop items involve two basic concepts. One consists of rooftop curbs flashed into the roof membrane with a sheet metal cap (NRCA

Detail Sheets “N: Curb Detail,” “L-2: Equipment of Sign Support,” “S: Pipe Roller Support”). The second concept consists of structural steel vertical posts supporting a structural steel framework (NRCA Detail Sheets “M-1/M-2: Mechanical Equipment Stand,” “Q: Structural Member”). See *Figures 2 and 3*.

CURBS

A flashed curb is typically constructed in two fashions: 1) individual curbs, sometimes referred to as “runners,” and 2) square/rectangular- or box-shaped curbs. The individual curbs are typically positioned at each end or along the sides of the item or piece of equipment to be sup-



Figure 1 – Overview of rooftop equipment.

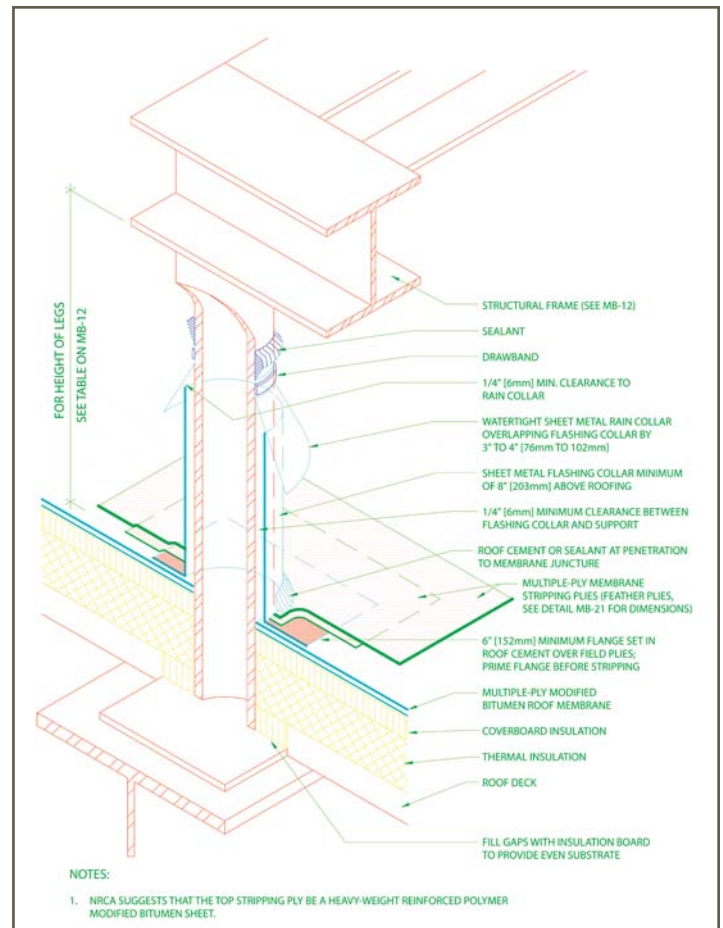
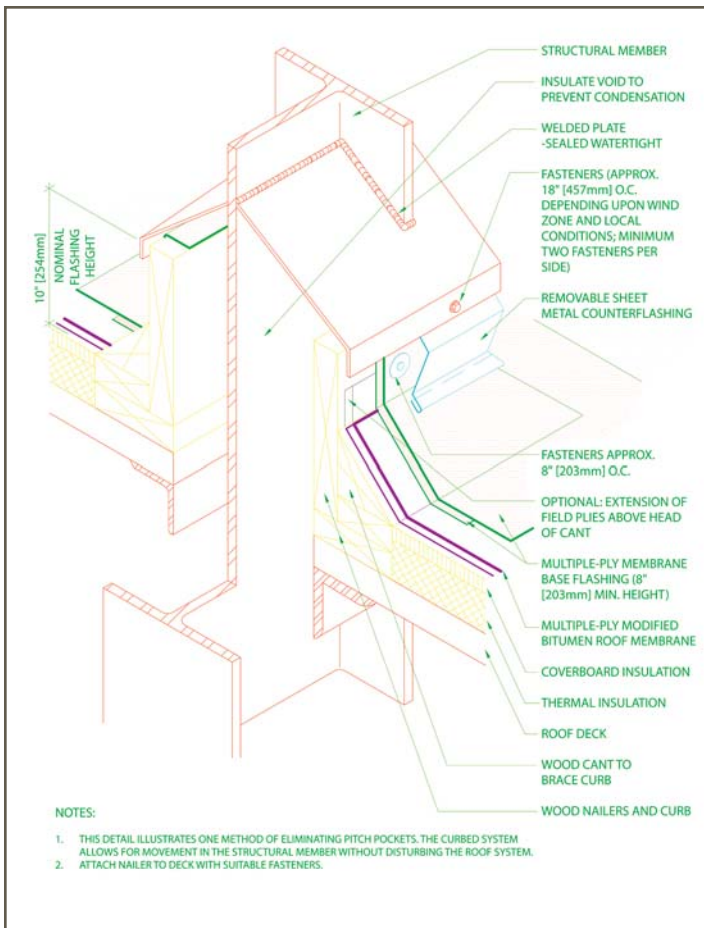

Figure 2 – NRCA Detail M-2.

Figure 3 – NRCA Detail Q.

ported (Figure 4). An additional individual curb can also be positioned at mid-span of the item, depending on its actual size or weight. For rooftop piping, the individual curbs are typically positioned approximately 5 to 10 ft on-center. The pipes are either placed directly on top of the curbs or on some type of steel support structure such as a roller or saddle that is anchored to the top of the curb.

When installed by a roofing contractor, the curbs can be constructed in the field using 2x dimensional lumber or shop-fabricated sheet metal. Premanufactured curbs constructed from sheet metal (commonly 16 gauge) are also readily available from various suppliers. These types of curbs are commonly made from galvanized sheet



Figure 4 – Equipment installed on curbs/runners.

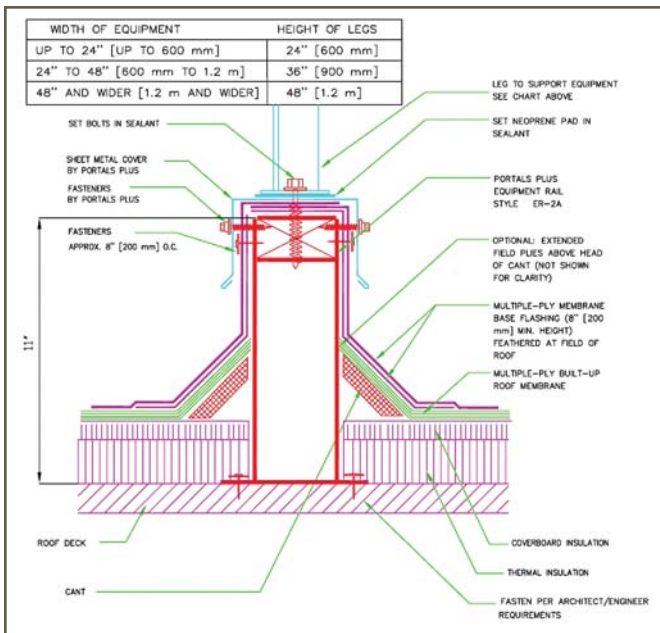

Figure 5 – Premanufactured equipment curb detail.

metal of various heights, 12 to 18 in, with canted or straight vertical legs. A wood nailer and metal cap are also often provided on top of these curbs. See *Figure 5*.

A box-shaped curb or frame can also be constructed using 2x dimensional lumber or purchased as a premanufactured unit to function as a support for various equipment. The curb can be left open to provide projections through the deck, or it can be provided with a cover (either plywood or metal cap). Equipment is then positioned on

rooftop items. A variety of steel shapes are used for constructing the vertical supports, including round shapes (pipes or posts), square-shaped tubes, wide flange shapes (I-beams), channels (“C” shapes), and angles. Light-gauge steel struts, such as “Unistrut,” are also used to support items more commonly associated with electrical related components such as disconnect boxes.

For ease of constructing proper flashings, the preferred support

top of the cover/cap and either relies on dead weight of the item or is anchored directly to the curb. These types of curbs are commercially available from several manufacturers such as ThyCurb, Portals Plus, etc.

STEEL SUPPORTS

Structural steel framework is typically utilized to support relatively large or heavy equipment and items such as cooling towers, storage tanks, generators, satellite dishes, etc., but also could be used to support other

shape is the cylindrical version or a pipe or post. A shop-fabricated sheet metal base or flashing pan can be installed around the post and then sealed with a pourable elastomeric sealant applied over a nonshrink, grout-based material. A sheet metal umbrella/bonnet is then attached to the post with a steel draw band (*Figure 6*). The bonnet functions as the initial line of defense against water infiltration and also provides protection to the pourable sealant from exposure to weathering elements and/or contaminants.

A square-shaped post is the next preferred support type with the utilization of a steel base. The sheet metal umbrella/bonnet can be secured to the square tube with self-drilling or tapping fasteners, preferably with a continuous termination bar. A steel bonnet could also be welded to the outer sides of the tube. The welded type of bonnet is less desirable (unless made as a two-piece assembly) than the screw-attached style for ease of removal for performing rooftop maintenance or for future roof replacement activities.

The various structural steel shapes, such as I-beams, channels, and angles, provide more difficult flashing conditions. Similar to the other penetrating supports, a steel base/pan can be installed around the support to provide the integral flashing sys-



Figure 6 – Sheet metal pan and bonnet installed at round post.



Figure 7 – Sheet metal bonnet installed at I-beam.



Figure 8 – Pre-manufactured penetration seal (“doughnut”) installed at steel support.

tem into the roof membrane, and a steel bonnet can be welded to the support (Figure 7). Several manufacturers, such as Portals Plus, SBS Industries, etc., offer specialty products that are produced to provide pre-manufactured flashing assemblies around these difficult shapes. The two-piece sheet metal flashing assembly is recommended regardless of the shape of the penetrating support.

Other products have been developed and promoted to provide options for constructing flashings around various penetrating supports. One of these products consists of premolded, rubber/polymer-composite, two-piece interlocking curbs or “doughnuts.” The doughnut is placed in sealant directly on top of the roof membrane surface and encircles the penetrating element. An elastomeric filler or pourable sealer is then installed within the doughnut in a fashion similar to that of a pitch pan (Figure 8). Since the sealer within the

assembly remains exposed, achieving a proper bond of the sealant to the penetrating element is critical for long-term, watertight performance. Manufacturers of this type of system include Chem-Link’s “Chem-Curb” and Millenium’s “Lockin Pocket.”

Another available flashing system consists of a liquid-applied coating, together with a reinforcing fabric. This system involves applying the coating system (liquid coating and embedded fabric) to the penetrating element and onto the roof membrane surface around the penetration to form a monolithic seal (Figure 9). Commonly



Figure 9 – Liquid flashing membrane installed at steel support.



Coal Tar:
First Choice for Flat Roofs

Durapax:
First Choice in Coal Tar

Roofing contractors & specifiers choose Durapax coal tar roofing systems.

- Coal tar roofing provides low cost and long life (25+ years)
- Many coal tar roofs last more than 50 years
- Coal tar’s cold flow properties provide self-healing
- Superior technical & customer support
- Delivery you can depend on
- Comprehensive warranties
- UL & FM approved systems

Specify your next flat roof with a Durapax coal tar roofing system.

610.579.9075

Durapax.com

DURAPAX
COAL TAR
COMMERCIAL ROOFING SYSTEMS



Figure 10 – Equipment installed on top of 4x4 wood sleeper.

available systems include “TeraPro” by Siplast, “Kemperol” by Kemper, and “Alsan” by Soprema. It may be possible that the coating flashing systems and the penetration pockets can be included in the coverage of the roof system warranty that would be provided by the roofing material manufacturer.

NONPENETRATING SUPPORTS

Another option for supporting various rooftop items is assemblies that do not penetrate the roof membrane, commonly referred to as nonpenetrating supports.

These supports range from basic wood blocking to engineered, pre-manufactured, steel strut assemblies. These nonpenetrating elements are placed on top of the roof surface with some type of protection/separation pad typically placed between the bottom of the support and the actual surface of the roof membrane/covering. Four-by-four dimensional treated or redwood lumber blocking is typically used and cut to a specific length to suit the application. Two-by-four dimensional treated lumber, stacked or individually, can also

be utilized. When utilized as a pipe support, the pipes are placed directly on top of the blocking and then sometimes secured in place with a sheet metal strap (i.e. conduit clamp or shop-fabricated metal straps). Wood blocking is commonly used to support rooftop piping such as electrical conduits, condensate drain pipes, gas pipes, and equipment. Wood blocking is also used to support other rooftop equipment, such as condensers, packaged units, etc. (Figure 10). Some obvious issues associated with wood blocking include deterioration and warping of the wood. Additionally, wood blocking will typically not allow for adequate movement and/or load distribution, which can result in damage to the roof, even with the installation of protection pads (Figure 11).

A wide variety of pre-manufactured, nonpenetrating assemblies is also available, ranging in style and materials. Some common

available products include ABS plastic saddles, sheet metal discs, and steel strut assemblies. These supports can be provided

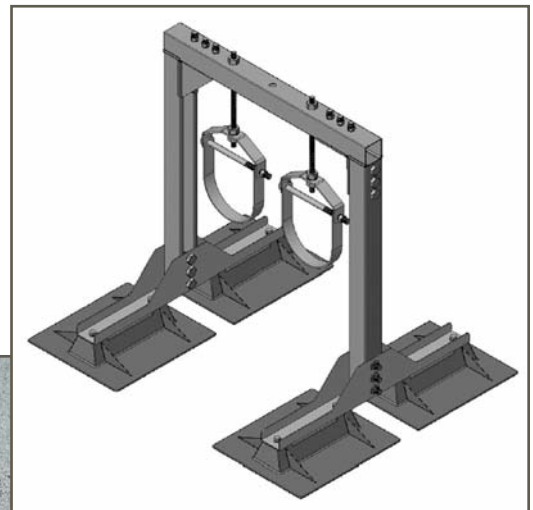

Figure 12 – Typical pre-manufactured pipe support detail.



Figure 11 – Damage to roof from movement of piping and support.

with either a bar or roller component to support the respective piping (Figure 12).

For larger types of pipes, such as insulated hot-water pipes, assemblies can be constructed in a standlike fashion with clevis, rollers, or saddle hangers suspended with threaded rods. The stands are commonly constructed with C-shaped steel struts (UniStrut) assembled with horizontal cross members and vertical support posts that are adjoined with brackets, angles, and/or gusset plates and installed with some type of prefabricated base to support the equipment and distribute the loads on the roof.

Assemblies are also available to support the various types of equipment that are often encountered on rooftops (Figure 13). Walkways, stair assemblies, crossovers, and assorted types of stands are available or can be customized to suit the application. These assemblies can be viewed as similar to erector sets for the roofing industry. A unique feature of the strut assemblies is the ability to customize each individual support to suit the existing size, number, direction, and/or configuration of the piping/equipment and rooftop conditions. These assemblies can also be engineered in



Figure 13 – Mechanical equipment installed on pre-manufactured support.

order to provide suitable support for the respective item while minimizing the impact on the roof (Figure 14).

SUMMARY

The decision to use curbs, penetrating steel supports, or nonpenetrating supports depends on several variables, including but

Roof Drainage Design

NEW e-LEARNING PROGRAM:



The new Roof Drainage Design e-learning course is designed for practicing consultants, architects, and engineers who desire to become more knowledgeable about designing roof drainage systems to be functional and to meet code.

[This is Not a Proper Exit]

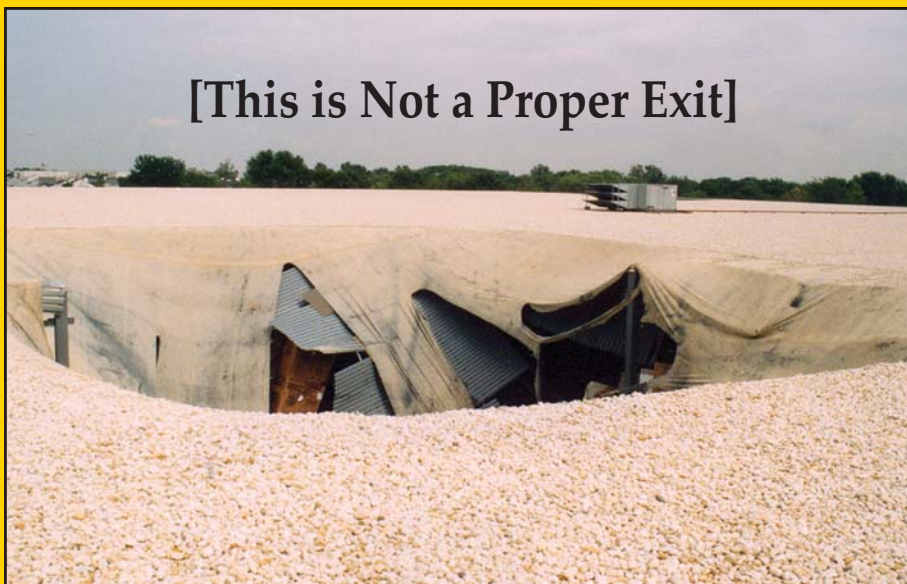

Topics include:

- Roof Slope to Drains
- Sizing Exterior Drains and Gutters
- Sizing Interior Drains
- Scupper Sizing

Students will learn to:

- Understand the guidelines for roof design to move water to drains
- Size gutters and downspouts per code and intended use
- Size primary interior drains
- Understand requirements for and sizing of secondary drainage
- Size scuppers appropriately for primary and secondary drainage

RCI, Inc.

800-828-1902

Enroll today @ rci-e-learning.org



Figure 14 – Satellite dish installed on premanufactured support.

not limited to the following: budget constraints, anticipated load capacity, owner and project requirements (wind/seismic loading), designer or installer preferences, and site constraints or limitations.

Some common issues regarding penetrating supports include:

- 1) Creation of additional penetrations in the roof membrane results in additional potential leak sources.
- 2) These types of supports are less flexible in regard to modifications or changes associated with adding, eliminating, or revising the piping and/or equipment.
- 3) This type of assembly can provide structurally sound supports for the piping/equipment that can adequately handle the necessary dead loads or seismic loads and/or movement/vibrations.

Common issues related to the nonpenetrating supports are:

- 1) Some of these assemblies (i.e., wood blocking) typically cannot allow for proper movement of piping, consequently resulting in possible damage to the underlying membrane.
- 2) These supports may not provide proper capacity for the element

Karl A. Schaack, RRC, PE

Karl A. Schaack, RRC, PE, is president of Price Consulting, Inc., a roofing and waterproofing consulting firm in Houston, Texas. Mr. Schaack has a bachelor's degree in civil engineering from Clemson University. He is a registered professional engineer in Texas, South Carolina, and North Carolina. Karl is a member of RCI, the Roofing Contractors Association of Texas, and the Gulf Coast Chapter of RCI. Karl is a former director of RCI's original Region IV and was the 2007 recipient of RCI's prestigious Richard M. Horowitz Award for outstanding contribution to *Interface* journal.



involved.

- 3) These supports can be readily rearranged and/or modified to adapt to changes in the piping and equipment.
- 4) The more "sophisticated" assemblies can be engineered to meet the necessary loading requirements or load distribution and can be installed directly by the manufacturer's personnel.

Over the past 10 years, the roofing industry has experienced a proliferation of a wide variety of products, assemblies, materials, and/or systems to offer solutions for supporting equipment and/or flashings of such supports. Whichever system or option is selected for supporting rooftop items and their related flashings should be properly designed, installed, and maintained in order to provide optimum solutions with the least impact to the roof covering. Just as with roofing materials, improper installation can result in physical damage to the roof covering, resulting in moisture infiltration. 

REFERENCE

NRCA Roofing & Waterproofing Manual

CONSTRUCTION DEATHS DECLINE

One silver lining in the downtrend of construction? Fewer deaths. The latest annual census report by the U.S. Labor Department's Bureau of Labor Statistics (BLS) shows there were 969 fatalities in the construction industry in 2008 – down 20% from 2007, but still the largest total among U.S. industries. The death rate in the industry fell to 9.6 per 100,000 full-time-equivalent workers in 2008 from 10.8 the previous year. While construction had the highest fatality numbers overall, it was third highest per worker, surpassed once again by the agriculture-forestry-fishing-hunting sector, with 29.4 per 100,000; and manufacturing and utilities, 18.0 per 100,000.

It was noted, however, that part of the decrease may also be that the demographic mix has also shifted in the past year. Seventeen percent fewer Hispanic workers were in the construction industry between 2007 and 2008, and Hispanics have a higher fatality rate than other workers.

Across all industries, total fatal workplace injuries in 2008 were down 10% to 5,071, the lowest annual figure since the BLS began its census in 1992. The fatal-injury rate also declined, from 4.0 to 3.6.