



# DESIGNING BUILDING ENVELOPES: TIPS, TRICKS, AND LESSONS LEARNED

**Peter M. Babaian,  
Emily R. Hopps,  
and Brent A. Gabby  
Simpson Gumpertz & Heger Inc.  
Waltham, MA**

## **ABSTRACT**

The combination of ever-increasing owner program requirements, focus on energy-efficient buildings, and expanded architectural design options makes building construction more complicated every day. Architectural features, use of multiple wall systems, and integration of new technologies, as well as complex geometries, constantly challenge the designer to produce a functional and aesthetically pleasing building that will provide long-term reliable service. The importance of the building envelope design is often underestimated in the process. This presentation will delve into key lessons learned from several reviews of recent building designs, including:

- Selecting appropriate wall systems for specific exterior and interior conditions.
- Maintaining continuity of barriers (water, air, thermal, and vapor).
- Integration of multiple systems.
- Assessing new and energy-efficient technology.
- General design considerations for the exterior envelope.

## **SPEAKER**

Peter M. Babaian is a staff engineer in the Waltham, MA office of Simpson Gumpertz & Heger Inc., a national design and consulting firm that designs, investigates, and rehabilitates structures and building enclosures. He has worked in both the structural engineering and mechanics and building technology divisions at SGH, and currently focuses on the restoration of historic and heritage buildings. Mr. Babaian's experience includes investigation, analysis, and rehabilitation of existing structures, design, and cost estimating, scheduling, and construction administration.

**CONTACT INFO:** [pmbabaian@sgh.com](mailto:pmbabaian@sgh.com) or 781-907-9000

## **CO-AUTHORS**

Emily R. Hopps is a senior engineer with SGH. She has experience in investigation, design, and rehabilitation of building envelopes of both modern and historic construction. Her building envelope work has included peer review and design consulting for new buildings and condition assessments and design of repairs for a variety of both public and private facilities. She received her BS in civil engineering at Northeastern University and can be reached at [erhpps@sgh.com](mailto:erhpps@sgh.com).

Brent A. Gabby is a principal with 12 years of experience at SGH and more than 20 years of experience in building restoration and reconstruction design. He specializes in investigation, diagnosis, and repair to resolve problems relating to historic building envelopes and structures. He has investigated and designed repairs for nationally and locally recognized landmarks and buildings. He can be reached at [bagabby@sgh.com](mailto:bagabby@sgh.com).

# Designing Building Envelopes: Tips, Tricks, and Lessons Learned

## ABSTRACT

The combination of ever-increasing owner program requirements, desire for energy efficient buildings, and expanded architectural design options makes every building construction project more complicated than the last. Mixed-use buildings that include residential, commercial, recreational, gallery, and/or sensitive equipment space within one facility result in competing design requirements. Architectural features, the use of multiple exterior envelope systems, and integration of new technologies, as well as complex computer-generated geometries, constantly challenge the design team to produce a functional and aesthetically pleasing building that will provide long-term reliable service. The importance of building envelope design is often underestimated in the process. Typical details, as provided by manufacturers, are frequently relied upon to define the building envelope without sufficient consideration of the building use and the physical properties of materials that comprise a building enclosure. Inappropriate or incomplete building envelope details can lead to construction complications and future building performance issues if these challenges are not met. This paper will discuss key lessons learned and offer tips from several reviews of recent building designs, including:

- Maintaining continuity of barriers (water, air, heat, and vapor).
- General design considerations for the exterior envelope.

- Integration of multiple systems.
- Assessing new and energy-efficient technology.

## INTRODUCTION

The primary function of the building envelope is to control the passage of air, moisture, water, thermal energy, and light into or out of the building, depending on the conditions. Sustainable construction and the desire to be “green” increase the complexity of buildings. The 2006 International Energy Conservation Code (2006 IECC), developed and published by the International Code Council, requires minimum thermal resistance and vapor retarders for all building envelope assemblies. Air barriers within enclosure assemblies, while not required in the 2006 IECC, are required in some states and countries, and are a good design practice. As a result of these complexities and requirements, increased attention must be given to the building envelope.

The waterproofing, insulation, air barrier, and vapor retarder are referred to as the “four barriers” of the building envelope. As architectural options continue to expand, these four barriers must be considered for all exterior wall and roof systems, and must be continuous and integrated properly. As the building envelope becomes more complicated, it is necessary to understand the functions of the four barriers and provide a well-detailed and thorough set of drawings and specifications for a properly functioning and durable building envelope.

This paper will review the basic concepts of the four barriers in the exterior envelope, discuss moisture migration and condensation, provide design recommendations for common exterior envelope systems, and briefly discuss recommendations to assess new exterior envelope technologies. The paper is focused on common issues found in recent peer reviews of exterior envelope systems in design documents. Specific issues are addressed as case studies to illustrate the design concept.

## THE FOUR BARRIERS

### The Water Barrier

The water barrier is the most important deterrent to prevent rainwater and groundwater from penetrating the building enclosure and wetting, deteriorating, and contaminating interior surfaces. To maintain a watertight building envelope, the water barrier must be continuous and/or adequately shingled in the direction of water flow. Water barriers on the building consist of roofing membranes (e.g., EPDM, PVC, TPO, or modified bitumen), below-grade waterproofing membranes (e.g., rubberized asphalt membrane or HDPE), cavity wall membranes (e.g., asphalt-impregnated felt or rubberized asphalt membrane), and barrier-wall components (e.g., glass in curtain walls or precast concrete panels). Flashing is a major component of an effective water barrier system. It collects and drains water out of the envelope and away from the building.

## The Heat Barrier

The heat barrier is vital for occupant comfort, energy efficiency, and prevention of condensation within walls and roofs. The perfect heat barrier does not exist. Heat transfer will occur from one side of a wall or roof to another as long as a temperature gradient exists across wall or roofing systems. All building materials have some level of resistance to heat transfer (referred to as the R-value). Common building materials with high thermal resistance (insulators) include extruded polystyrene, glass fiber batt, polyisocyanurate, and spray-applied foams. Metal is highly conductive and has a low R-value. Because heat barriers control heat loss or gain (depending on the climate), building codes require a minimum amount of thermal resistance for the wall and roof systems of residential, commercial, and institutional structures. "Bridges" in the thermal barrier occur when certain portions of the building are left uninsulated or poorly insulated (e.g., parapets, fenestration perimeters, metal wall studs, or wall and roof penetrations), or if structural elements penetrate the exterior envelope. Thermal bridges can lead to concentrated heat loss at these locations and condensation when moist air contacts these relatively cold surfaces.

## The Air Barrier

Air infiltration or exfiltration is driven by air pressure differentials across a wall or roof system. Pressure differential is created by one of, or a combination of, stack ("chimney") effect, mechanical pressurization, and wind. The air barrier controls pressure differentials and restricts warm, moist air from migrating across the wall or roof system and reaching colder surfaces on which it can condense. The air barrier also restricts loss of heated or cooled air to reduce the building's energy

demands. The location of the air barrier within a wall or roof system is not usually critical, but it must be rigid or applied to a structural backing to withstand the exerted air pressures. However, if the air barrier functions as the vapor barrier, then the location of the air barrier is critical to the overall performance of the system.

## The Vapor Barrier

Some level of vapor diffusion will occur through most building materials. As a result, vapor barriers are more accurately described as vapor retarders. However, for the sake of simplicity and consistency, we refer to the vapor-resistive layer as the vapor barrier.

Vapor migrates through a wall either by diffusion through the building materials or by air movement. Where the air barrier protects against vapor transfer via air movement, the vapor barrier restricts vapor diffusion through building materials. Vapor diffusion is driven by vapor pressure differentials across the building envelope that reflect the tendency of warm, moist air to migrate to cooler, dryer conditions.

Vapor migrating across a wall or roof section can condense as it comes into contact with colder surfaces. The predominant direction of vapor diffusion depends on the climate: interior to exterior in cold climates, and vice versa in hot climates. The vapor barrier should generally be placed on the winter-warm side of the insulation in heating climates and vice versa in cooling climates, so that the vapor migration is arrested before it reaches colder surfaces. Vapor diffusion is a slow, steady process; air flow, by contrast, can carry large volumes of moisture rapidly. Condensation from air exfiltration can be orders-of-magnitude greater than condensation, due to vapor diffusion.

## Continuity and Integration

In order for each of the four barriers to function effectively, they need to be continuous around the exterior envelope of the building. Any breach in the water barrier is a potential leak into the building. If the insulation is not continuous around the exterior envelope, thermal bridges will occur that allow heat to escape to the exterior and waste energy, cool interior surfaces, and increase potential for condensation, potentially creating occupant discomfort. Openings in air barriers can result in significant exchange in tempered air, as well as increase the possibility of condensation. Noncontinuous vapor barriers can lead to condensation as well, by allowing vapor to move through the system.

Defects and discontinuities in air barriers generally cause much more serious condensation problems than defects or discontinuities in vapor barriers, particularly in buildings with humidified interior environments. The problem is exacerbated when the mechanical system is balanced to create positive air pressure on the interior of the building and the interior of the building is humidified, as is the case for hospitals, art space, natatoria, and other artificially humidified buildings.

Proper placement of the barriers also needs to be considered. As design continues to evolve and integrate multiple exterior systems on a building, the barriers need to be integrated and aligned. Exterior systems often have different thicknesses that result in different placement of the barriers within the wall. If the barriers are misaligned within a wall system, they will not be continuous. In addition, as systems transition, the same barrier function may be performed by dissimilar materials that need to be appropriately integrated. For instance, a window relies on the glass to be the water,

heat, air, and vapor barriers, while the wall around it may rely on two or more materials in different planes to serve the same function. Design drawings often do not focus on the integration of the different systems and maintaining the continuity of the barriers.

## COMMON ENVELOPE DESIGN ISSUES

### EXTERIOR WALLS

#### Barrier Wall Systems

Barrier wall systems have historically been limited to load-bearing masonry structures. These structures are designed to absorb water not naturally shed from the exterior surface, store it, and release it back to the surrounding atmosphere. The ability to store water can create many problems within the structure, and the development of the cavity wall eliminated these problems. With the need for faster construction, barrier wall systems such as precast concrete panels are once again popular as exterior wall claddings. It is challenging to maintain the continuity of the four barriers in barrier wall systems because the exterior cladding itself is the water barrier. Water is prevented from penetrating the barrier wall or absorbed into it, stored, and released in dry conditions. The barrier wall may also act as an air barrier.

Modern precast concrete wall systems typically consist of precast concrete panels, insulation, and a metal stud wall with interior finishes (*Figure 1*). Since concrete is a relatively dense material, the exterior precast panels, if well sealed at their perimeter joints, will generally function as effective water and air barriers, leaving only the heat and vapor barriers to be selected by the design professional. An insulation material that will provide intimate contact between the insulation and precast concrete, such as

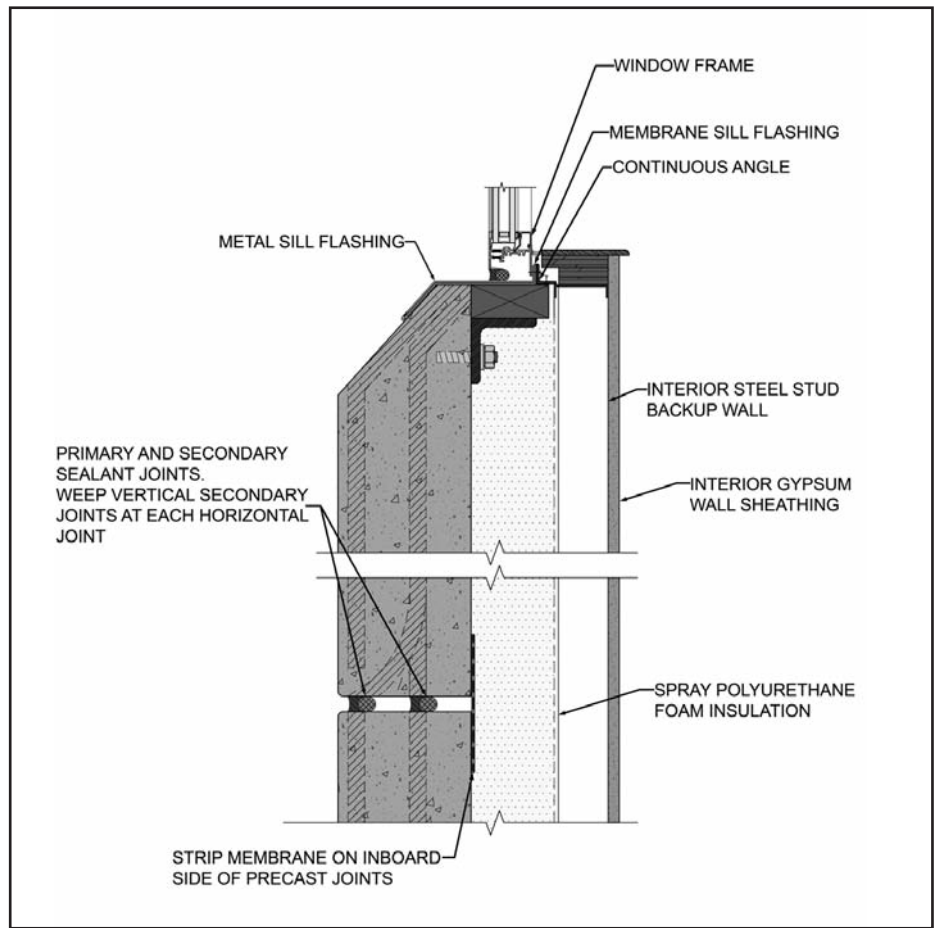

**Figure 1 – Continuity of barriers (water, thermal, air, and vapor) in a precast concrete wall system.**

spray polyurethane foam, is essential to prevent condensation on the inboard side of the concrete. Continuous contact between the concrete and insulation will limit the amount of interior air that can reach the cold, inboard side of the precast concrete. Rigid or batt insulation used as the thermal barrier cannot be installed air-tight to the inboard face of the precast concrete panel, so the potential for warm interior air to migrate behind the insulation is high. The type and thickness of spray polyurethane foam used in precast concrete barrier walls must be carefully selected to provide a balance between insulating value and vapor permeability. The insulation also helps control vapor diffusion while still allowing the precast concrete to release absorbed

moisture.

In a barrier precast wall system, the continuity of the water and air barrier are also a challenge, as they are intermittently interrupted by joints between panels. Traditionally, joints between precast concrete panels are detailed with a single bead of sealant, but time has proven that sealant will not remain water- and air-tight in the long term. Providing dual sealant joints on the exterior and a membrane strip (e.g., uncured EPDM) on the inboard side of the joint will increase the reliability and durability of the joints. Weeping the inboard sealant joint at each floor level will drain any water that may bypass the exterior sealant while maintaining continuity of the four barriers.

The installation of windows in precast concrete wall openings must take into account continuity of the water and thermal barriers. Locating the windows within the thickness of the precast concrete creates an inherent discontinuity in the thermal barrier, since the window's thermal break cannot be aligned with the interior insulation. Adjusting the location of the window to the inboard side of the precast concrete will reduce the amount of thermal bridging at the window perimeters. Installing angles around the entire interior perimeter of the window opening will provide attachment locations for the windows that allow for better alignment with the wall's thermal barrier. Interior angles will also provide flashing and attachment locations that will assist with the continuity of the water barrier. The angles allow the flashing membrane to extend to the inboard side of the window and form upturned legs, and window attachment locations that

will not penetrate the flashing membrane in vulnerable horizontal locations.

### Water-Managed Wall Systems

Water-managed wall systems typically consist of an exterior cladding and interior backup wall separated by a cavity space. The exterior cladding does not need to be watertight since, if detailed properly, the cavity space will allow water to drain from the system without contacting sensitive interior surfaces. Water-managed systems include masonry veneer, metal panel systems, stucco, and drainable EIFS, to name a few. Curtain wall systems can also be water-managed wall systems if they are designed to manage water that bypasses the exterior seals and direct it out of the system, typically through internal weeps holes in glazing pockets or at perimeter flashing locations.

In a water-managed system, the water, air, and vapor barrier

are often combined in one membrane applied to the exterior sheathing. In this case, the insulation is often applied to the exterior side of the membrane. This configuration places the barriers in the proper configuration for both winter conditions in the heating climates and summer conditions in the cooling climates. The air barrier, which needs a structural backup, is directly applied to the exterior sheathing. This system works in all climate types and is referred to as the "works-everywhere wall" (WEW) throughout the remainder of this paper (*Figure 2*). If the insulation is placed on the interior side of the exterior sheathing (e.g., between metal studs), then the vapor barrier must be separated from the air and water barriers and placed on the interior of the insulation for heating climates. In cooling climates, this configuration may lead to condensation when humid, exterior air migrates through the wall and contacts the

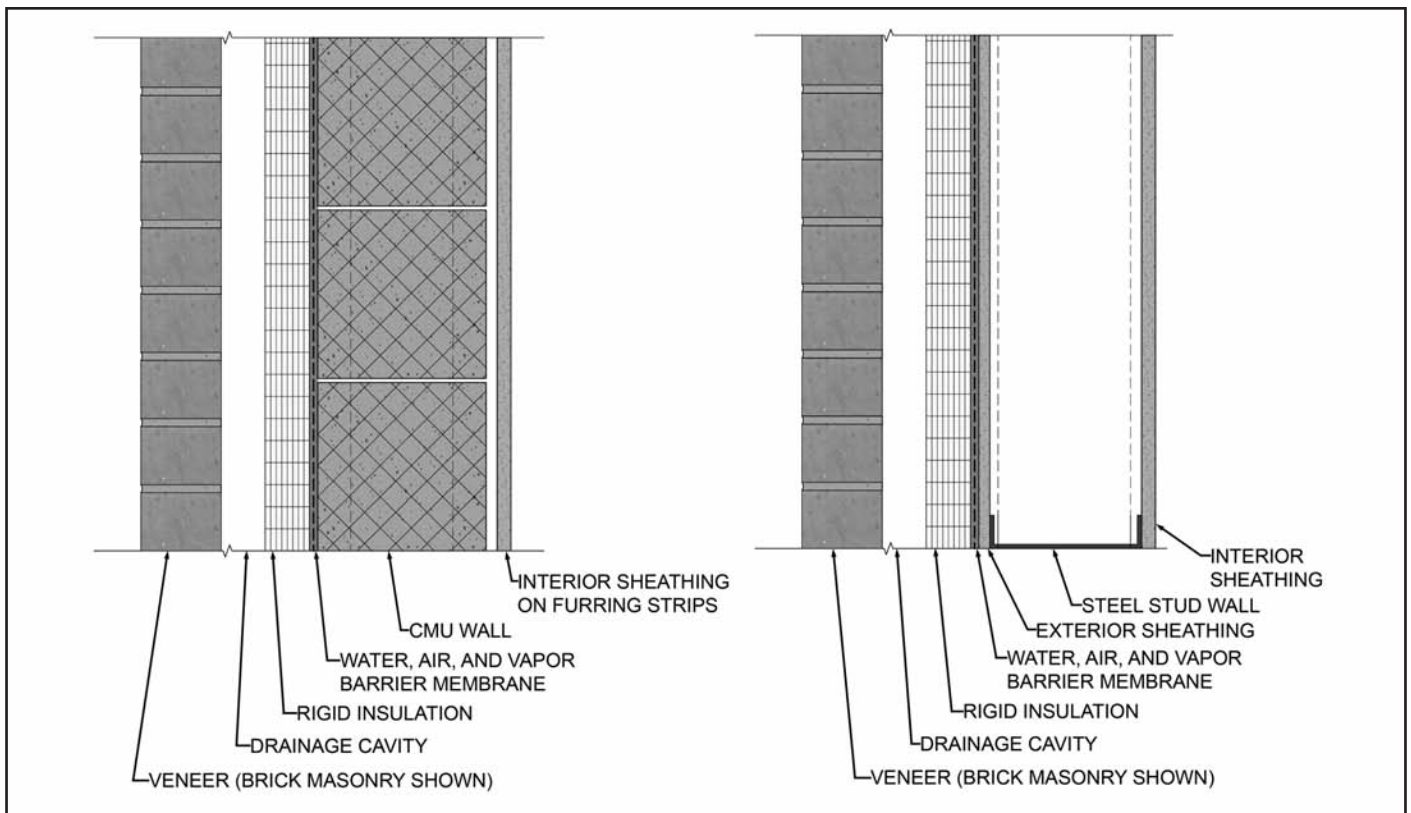

**Figure 2 – Works-Everywhere Wall for concrete masonry unit (CMU) and steel stud backup.**

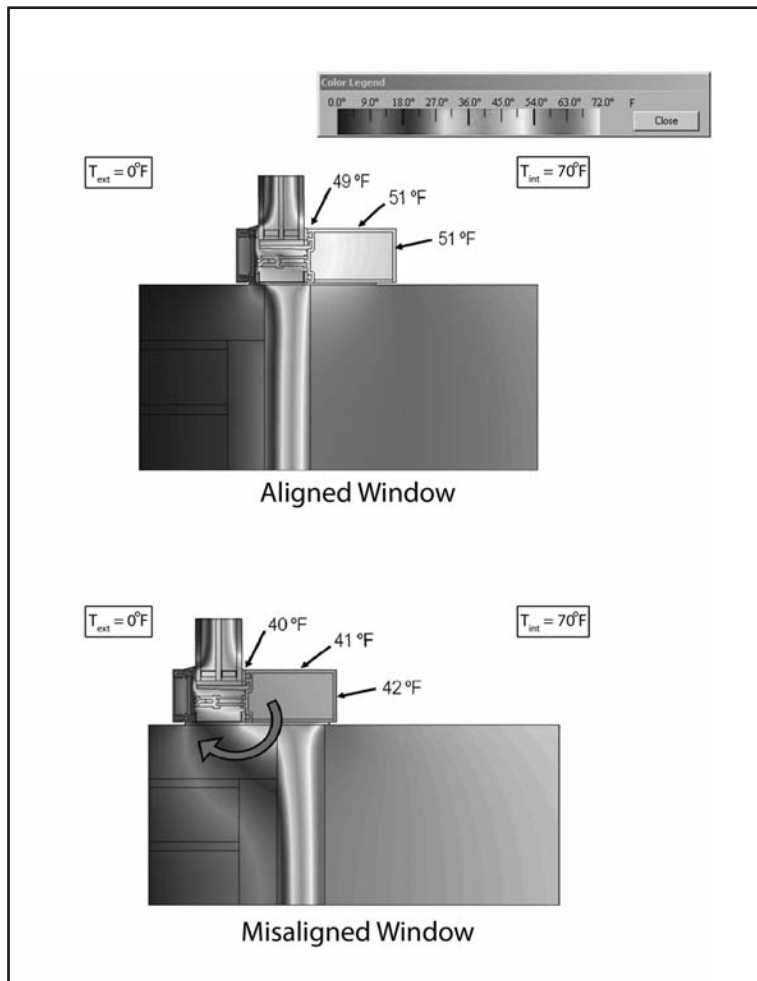

**Figure 3 – Thermal gradients of aligned and misaligned windows.**

interior vapor barrier. For the design tips that follow, the WEW is the assumed construction.

In the WEW, all four barriers are reduced to two planes that need to be kept continuous around the envelope of the building. Window penetrations are notoriously difficult for maintaining continuity of the barriers and providing integration with the window system. Often, architectural features such as returns or veneer materials of differing thickness are employed at the punched-window locations. When detailing around punched-window openings, the two important concepts to remember are:

1. Keep the glass and the thermal breaks in the windowframe aligned with the

adjacent wall insulation, or add insulation at transitions to maintain continuity of the thermal barrier (Figure 3), and

2. Make sure the air, water, and vapor barriers connect to the frame to maintain continuity of the barriers (Figure 4).

The easiest way to maintain alignment of the insulation is to reflect any changes in plane of the exterior veneer in the backup wall, if possible. If the backup wall cannot be modified, another possibility is to use a thinner piece of insulation to maintain continuity of the heat barrier and cavity space in the wall system. To maintain continuity of the water barrier, completely wrap the rough opening of the window in membrane waterproofing before window installation. Once the interior attachment angle is installed, place a strip of membrane waterproofing from the wrapped rough opening to the angle. If construction sequencing prohibits flashing installed prior to window installation, an alternative is to wrap a strip of mem-

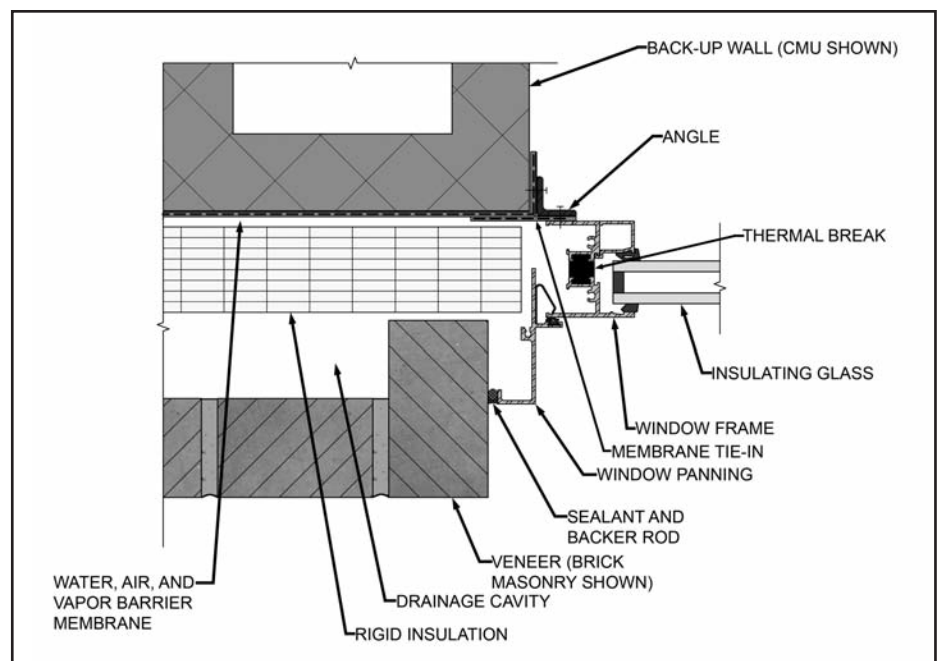
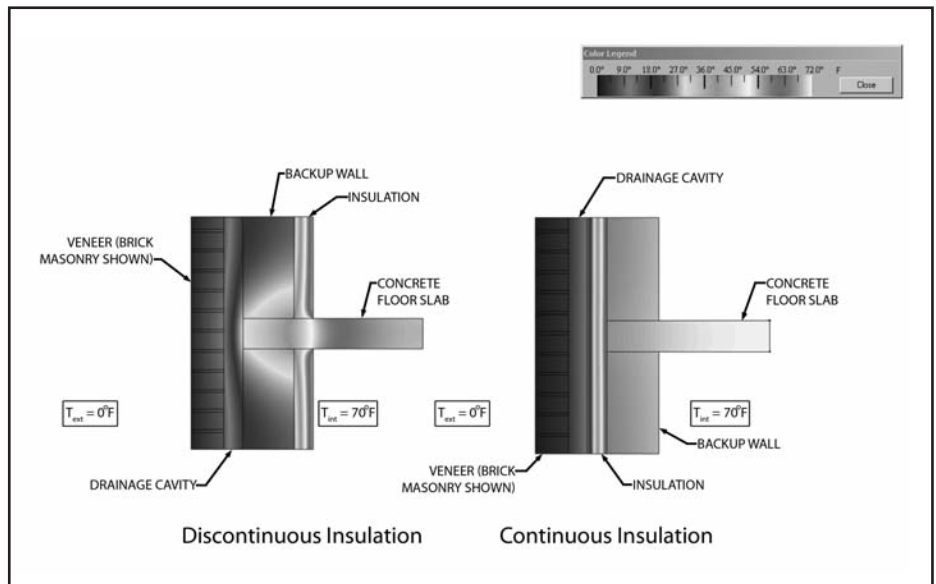

**Figure 4 – Water, air, and vapor barrier connection to windowframe at jamb (similar at head and sill conditions) and alignment of thermal barrier.**

brane from the rough opening onto the windowframe from the interior. To maintain adhesion, overlap the strip at least one inch on the membrane in the rough opening and the windowframe.

Projecting elements are a common architectural feature found on buildings today, typically canopies and sunshades. In a WEW system, projecting elements are easy to flash using membrane waterproofing such as an EPDM flashing boot integrated with the wall membrane. Uncured EPDM is a good material for flashing as it can provide adhesion to many wall components and allows for proper shingling. The continuity of the insulation is a problem as the projections act as a thermal bridge to the interior. In a humidity-controlled building in a cold climate, condensation may form at the location of the projecting element. Thermal modeling of the wall at the location of the projecting element can identify the potential for condensation (*Figure 5*). Similar to a canopy or overhang is an extended floor slab that penetrates the exterior envelope, such as a continuous floor slab balcony. In this case, insulation cannot be kept continuous around the slab and, along with potential condensation in humidity-controlled buildings, as cold spots in the floor slab can develop. Localized heating, such as fin tubes, can reduce occupant discomfort at slab penetration locations.

In water-managed systems, flashing is used to manage the water and direct it out of the wall system. Placing flashing above wall openings, at the base of the wall, and similar locations where downward flow of water can find its way into the building is critical. Flashing should be a durable material that will last as long as the veneer material so that it does not have to be replaced before the veneer. Metal flashings provide



**Figure 5 – Thermal gradients at continuous and discontinuous insulation at floor slabs.**

the most durable installation. Flashings should always have slopes that direct water toward the exterior of the wall. They should also extend past the exterior face of the veneer with a drip edge to prevent the water from finding its way back into the wall system. Since water can travel along the length of the flashing or have drainage slowed by clogged weeps, the use of upturned legs and end dams will prevent water from flowing to adjacent areas.

Water-managed systems that have a metal panel veneer need to be vented to prevent a vapor trap from forming, especially if the panels are sealed, as metal acts as a vapor barrier since it has no permeability. By placing a vapor barrier on either side of the insulation in the WEW, a vapor trap can be created. While this may not be an issue for the backup, due to the installation of a waterproofing membrane, the metal panels, such as zinc, may degrade from the constant exposure to moisture. In order to prevent the vapor trap, vents should be installed in the panel system with openings at the base and the top

of the wall system to encourage airflow.

Curtain wall systems typically include captured-glazed, structurally-glazed, and point-supported structural glass. For all systems, the glass acts as the primary water, air, vapor, and heat barrier. The captured-glazed system is the most common of the three systems. Water that penetrates the exterior seals of the captured-glazed system is directed through the glazing pockets and eventually wept out to the exterior. The most reliable curtain wall systems are drained within each glazed opening and horizontal glazing sills are end-dammed to prevent water from draining into the vertical mullions. Structurally glazed and point-supported systems rely solely on the exterior sealants to prevent water intrusion, since they do not have a means of draining water that penetrates the exterior seals. These systems act as barrier wall systems and rely heavily on the sealant for waterproofing purposes.

Integration of curtain walls with the water, heat, air, and vapor barriers of an adjacent wall

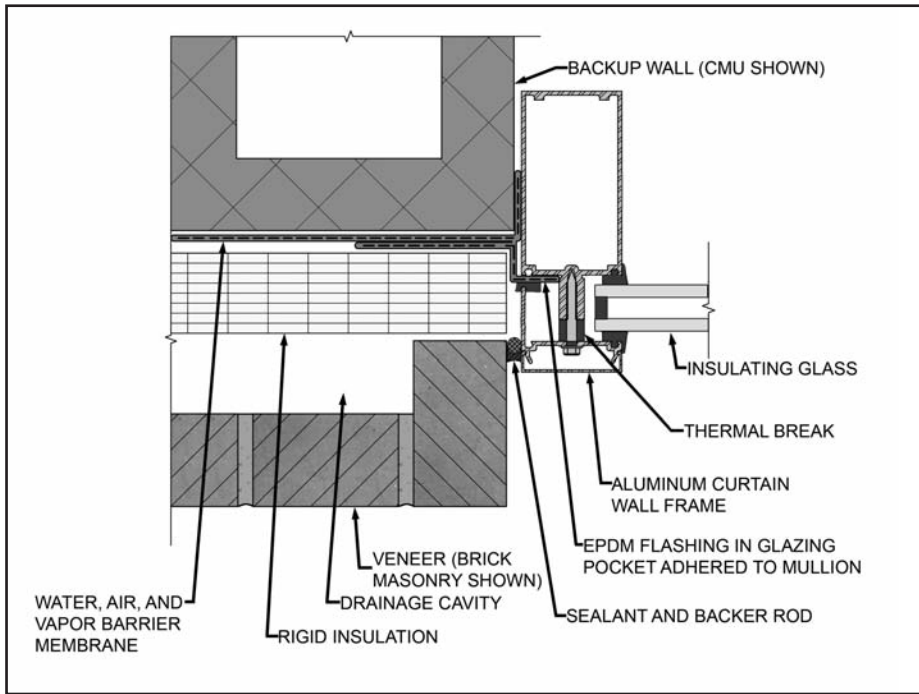

**Figure 6 – Integration of water, air, and vapor barriers with curtain wall frame and alignment of thermal barrier.**

system can be accomplished in one of two ways. The insulation should be aligned with the thermal breaks in the curtain wall frame, similar to the windows discussed above. The water barrier can also be connected to the curtain wall frame in a manner similar to windows. Alternatively, the membrane can be connected directly into the curtain wall glazing pocket on the exterior (Figure 6). This is especially desirable when the interior finishes of the curtain wall are to be completely exposed. EPDM or other waterproofing membranes can be installed in the glazing pocket around the curtain wall perimeter and adhered to the wall waterproofing membrane, provided the materials are compatible. At the sill of all curtain walls, flashing should be installed to prevent water from entering the wall system below. To provide a continuous flashing at the sill, intermediate horizontal mullions with coped vertical mullions should be located along the sill in lieu of standard end frames. Placing the

curtain wall on a raised concrete curb also helps guard against water penetration at the sill.

Storefront systems are often considered in place of curtain wall systems. Storefront glazing sys-

tems, as compared to curtain walls, perform less reliably and durably. Transitions between the air, vapor, and water barriers are more complicated since the air barrier plane (tie-in location) for storefronts is seldom defined by the manufacturer. Many storefront systems also drain down the vertical mullions without compartmentalized drainage on the horizontal mullions. The horizontal-to-vertical joint in storefront framing is inherently vulnerable to water. Storefronts cannot span large distances without significant deflection. They also require starter subsills that perform the function of a sill flashing with details required for butt joints, end dams, and integration with jamb flashings.

### Roofs

To maintain continuity of the four barriers, the roof must be integrated with the exterior wall systems. Typical roofing systems involve placement of a vapor barrier on concrete or steel structural deck insulation layers, and roof membrane. Integration of the roof system with the wall systems

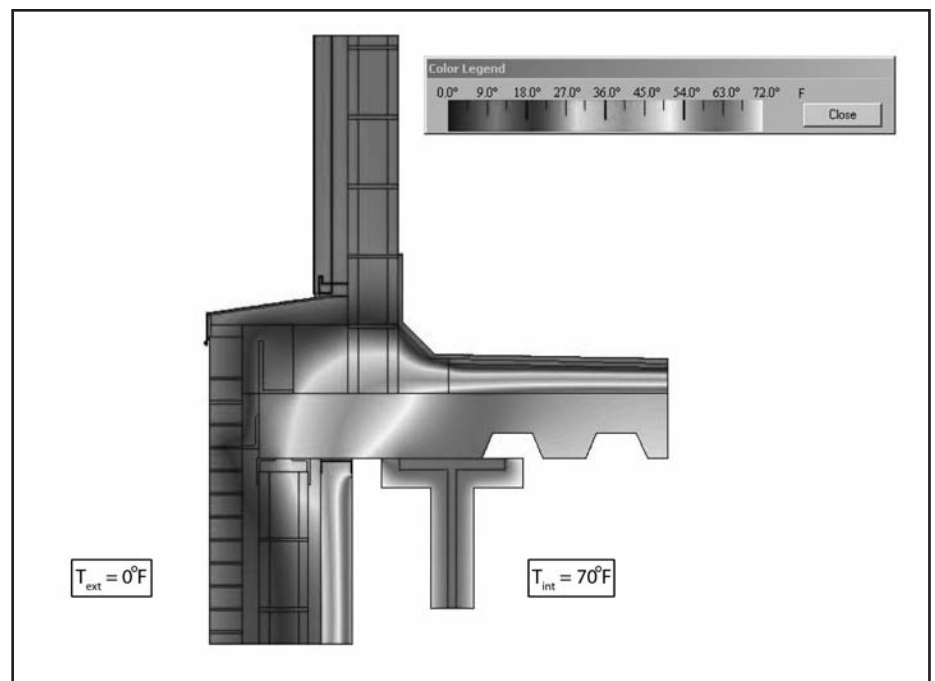

**Figure 7 – Thermal gradients at a masonry parapet.**

becomes difficult where parapets or other architectural features occur at the edge of the roof. In roof systems, the vapor barrier is most commonly a different material and layer than the roof membrane (water and air barrier), whereas in wall systems, the water, air, and vapor barriers are often one combined membrane. The transition must be detailed such that each is continuous. In addition, through the transition, the insulation must be maintained continuously so that the thermal barrier is not interrupted. For parapets, carrying the insulation around the exterior of the parapet will maintain continuity of the thermal barrier but may not solve the problem of the parapet acting as a heat fin, depending on the size of the parapet. Heat fins created by large parapets exposed to the exterior on both sides tend to cool the interior wall-roof intersection below the parapet, increasing the potential for condensation in this location. Thermal modeling can assess the risk of condensation for particular situations (Figure 7).

Penetrations through the roof membrane are also a typical detail that occurs in building projects. Most penetrations are vent stacks or curbs that are easily flashed due to their shape. In many instances, columns will extend through the roof membrane to support steel grillage for large mechanical units, such as chillers. Since structural columns tend to be wide flange sections, they are difficult to flash due to their geometry. Whenever possible, end the wide flange columns below the roof level and install posts up off the roof beams or column-top plates with a round steel or tube steel section, as they are easier to flash with witches' hats or other boot-type flashing.

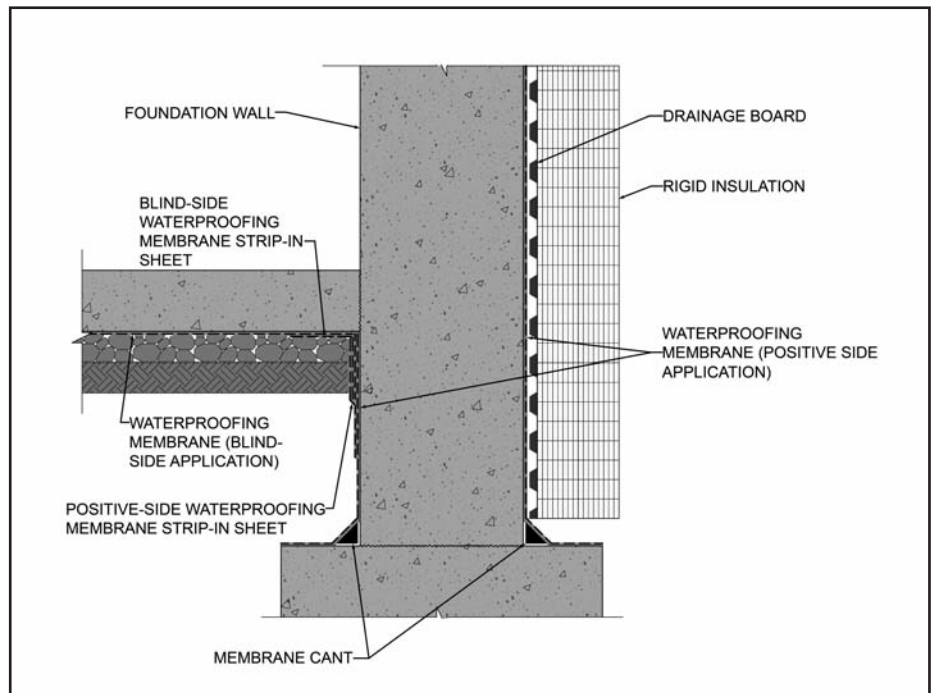

**Figure 8 – Below-grade membrane waterproofing.**

### Below-Grade Waterproofing

Below-grade building enclosure components are typically constructed with reinforced concrete. Similar to the precast concrete wall system, the below-grade concrete structure can function as an air and vapor barrier. However, concrete alone may not be an effective water barrier if exposed to standing water and a hydrostatic head, particularly where cracks may develop in the concrete structure.

Typical specifications for protecting below-grade structures require a dampproof coating applied to the exterior walls. Consultation with the geotechnical engineer regarding the location of the water table at the project site is required to determine if the below-grade walls and slabs will be exposed to a significant hydrostatic pressure. Damp-proofing membranes retard the flow of water, but will not act as waterproofing. The presence of a hydrostatic head requires the specification of a true below-grade

waterproofing membrane, especially if leakage into the below-grade area cannot be tolerated (Figure 8). Waterproofing, not just a typical sub-slab vapor barrier, may be required below the foundation slabs, depending on the sensitivity of the interior floor finishes to moisture. Occupied below-grade spaces should also be insulated to reduce the potential for condensation and enhance energy efficiency and occupant comfort in cold climates.

Integration of below-grade waterproofing with above-grade wall waterproofing is also required. The transition between above- and below-grade waterproofing systems should always occur above grade level. Transitions that occur below grade level leave the interface exposed to wet soils and potential standing water. Separation sheets may be required between the two membranes due to incompatibility between above-grade and below-grade membranes.

## **NEW TECHNOLOGIES**

New technologies continuously evolve as architecture pushes the boundaries of conventional design. All new technologies should be reviewed for both their benefits and drawbacks. A balance needs to be reached between waiting for new technologies to be tested and proven in-service and the early use of the technology. Waiting even a few (three to five) years to evaluate the service record of a new technology may reveal short-term deficiencies and long-term trends.

An alternative to waiting for in-service information on new technologies is to conduct accelerated laboratory and field testing. Accelerated testing in the laboratory, such as weathering and freeze/thaw resistance, can simulate many years of in-service conditions, but it does not replicate actual exposure and is most useful for comparative evaluation of materials. Field testing, especially

through the construction of mockups, can reveal potential construction or integration issues. If testing is completed early, issues can be resolved and not delay the construction process. It is also important to present as much information as possible to the owner so that they can make an informed decision about employing the new technology on their project. ASTM E1825, "Standard Guide for Evaluation of Exterior Building Wall Materials, Products, and Systems," provides guidance when considering the use of new materials.

Many manufacturers offer warranties designed to encourage the use of the product. Warranties on new products with little or no track record are based only on performance expectation and are not backed by an actual performance record. The best warranties for performance are time-tested materials and good design practice.

---

## **SUMMARY AND CONCLUSIONS**

Maintaining continuity of the four barriers of the exterior envelope -- water, air, vapor, and heat -- is critical to the design of a properly functioning and durable building envelope. Moisture migration and condensation within the exterior envelope cannot only lessen the durability of the envelope, but also lead to unintended consequences, such as energy loss, condensation, leakage, and mold growth. Proper detailing of the most common envelope systems, as discussed above, will provide the necessary system integrations to help keep the barriers continuous and the envelope functioning as intended.

