

A Flash in the Pan -

A Field Guide for Windows and Doors

By Robert Bateman

WHAT'S NEW

The latest standard for window and door installation, ASTM E2112-07, Standard Practice for Installation of Exterior Windows, Doors, and Skylights, recommends sill pan flashing under all windows and doors for low-rise residential and light commercial buildings, with a few generalized exceptions.

The 2006 International Building Code (IBC) is now generally adopted and recognized as the single national building code in the United States. It has new requirements that address the importance of flashings for the weather protection of buildings.

Although ASTM E2112-07 defers to window and door manufacturers for installation instructions, it remains the default voluntary standard if there are no specific recommendations from the manufacturer. Also, if there is no flashing design provided on the construction docu-

ments for a particular building project, then ASTM E2112 provides guidance.

A complete sill pan flashing assembly is shown in ASTM E2112 (See *Figures 1 and 2*). The conceptual configuration illustrates and identifies the necessary parts of the flashing for a window. A door's sill pan flashing would be similar but adjusted for the substrate and floor-level conditions on either side of the threshold. The important items in these drawings are the configura-

tions and the identified parts making up a complete pan.

Sill flashing definitions can be found in ASTM and other sources. Useful terms for evaluating assemblies include:

- **Sill pan** - The horizontal bottom part of a window or door.¹
- **Pan flashing** - A type of flashing used at the base of large openings or penetrations such as doors or windows. Pan flashings are designed to collect water and drain water directly to the exterior or onto the weather-resistant barrier. Pan flashings have an upturned inner leg and upturned end legs, which form a three-sided pan.²
- **Sill Protection** - A water-resistant covering provided for sills of rough

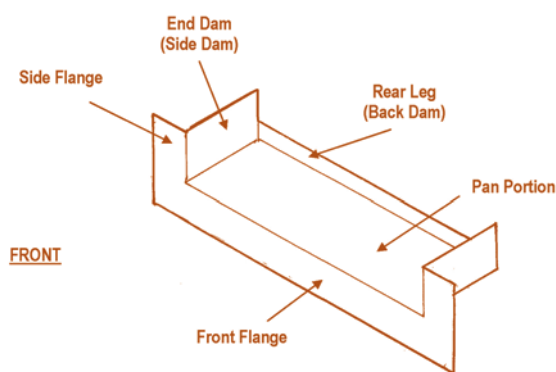

Figure 1 - Sill pan flashing configuration (based on ASTM E2112).

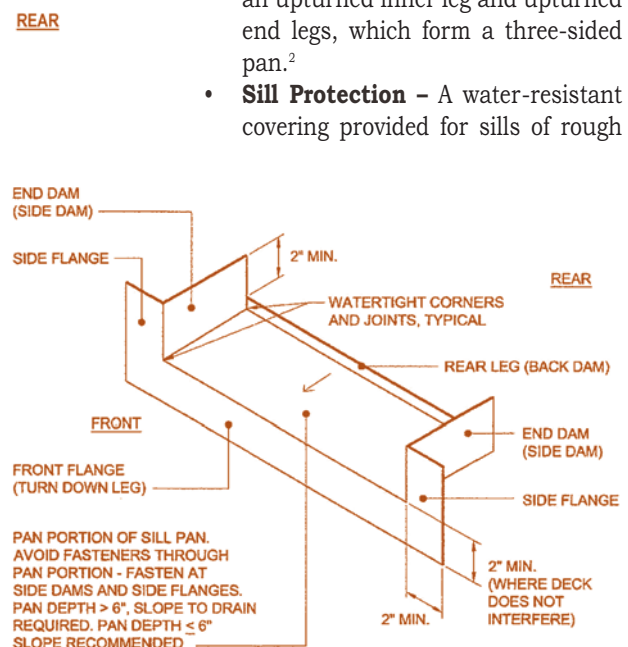

Figure 2 - Sill pan flashing configuration (excerpt from ASTM E2112-07, Figure A3.4).

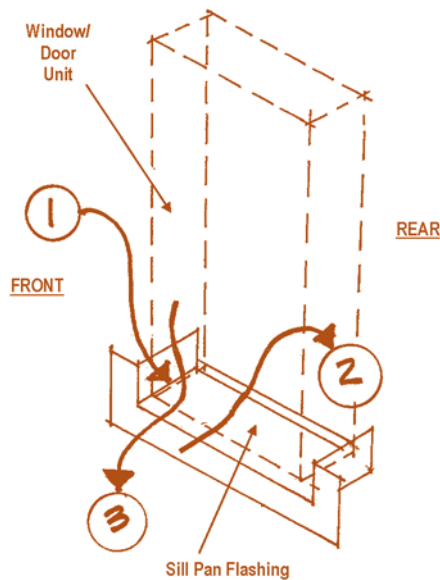

Figure 3 – Sill pan flashing collects and drains water from different sources.

openings that lack a true pan feature.³

These terms help to differentiate shapes and configurations of sill pan flashings. Other sill pan configurations without all of the parts may not be effective at controlling leaks. The sill pan flashing shown in ASTM E2112 is a complete assembly that does the most to manage incidental water (see Figure 3).

ASTM E2112-07 is intended to include recommendations for different building construction types, such as barrier walls (solid brick, masonry, concrete, precast and metal/composite panels) and drainage walls (siding, paneling, stucco, and certain veneer claddings). The standard has the most comprehensive descriptions and illustrations for framed walls – wood or metal. This paper focuses on the pan configuration typically used with framed walls with sheathing supporting a concealed water-resistant barrier (WRB), e.g., building paper or housewrap (see Figure 4). The *Field Guide* (see Appendix 2) will include all types of sill pan flashing examples.

When the WRB is behind the exterior cladding with concealed drainage walls, the integrated flashing can be chosen from a variety of materials. ASTM E2112-07 recognizes four available flashing material and fabrication methods. Table 1 shows an expanded table based on ASTM’s Table 5, revised to

include liquid-applied coatings (“liquid membrane”), i.e., Type V.

The recent use of vapor-permeable, liquid-applied WRB has not yet been addressed by ASTM E2112. Although recently promoted for commercial buildings, liquid-applied flashings and liquid-applied weather barriers are more common with drainage barrier EIFS applications, primarily in the residential market. ASTM Table 5 could be modified in the future to include liquid-applied flashings and identified as Type V.

WHAT’S GOOD

With the recent attention being paid to the importance of sill pan flashings, there are more references available that address the subject. The 2006 IBC and ASTM E2112-07 have examples with some good information.

CONSTRUCTION DOCUMENTS

2006 IBC, Sec 106.1.3, requires construction documents to show details of the “exterior wall envelope as required, including flashing,... corners, end details,... water-resistive membrane, and details around openings.” This code requirement should improve the quality of building plans.

PERIMETER FLASHING

Weather protection is emphasized in 2006 IBC, Section 1403.2. Opening flashing is spelled out in 2006 IBC, Sec. 1405.3, which notes, “[F]lashing shall be installed at the perimeters of exterior door and window assemblies.” This code requirement should improve the attention builders apply to con-

struction.

SILL PAN FLASHING

The compiled section on pan flashing in ASTM E2112-07 is now easier to navigate. There are minimum dimensions provided for pan flashings. The pan illustrations are shown in three dimensions (3-D), so the critical sill-jamb corners can be shown to be uniform and continuous (see Figure 2). Different materials and fabrications are illustrated (see Appendix 1).

The pan configuration is shown and defined to contain and manage water infiltration from different source locations (see Figure 3). The ASTM E2112 definition for pan flashing includes an important defining note.

Note – Pan flashings have up-turned legs at the interior edge and ends of the rough opening to form a three-sided pan. They are intended to collect and drain water toward the exterior, including water that may enter through the window unit (for example, between the jambs and sill) or around the window (between the rough opening and the fenestration).

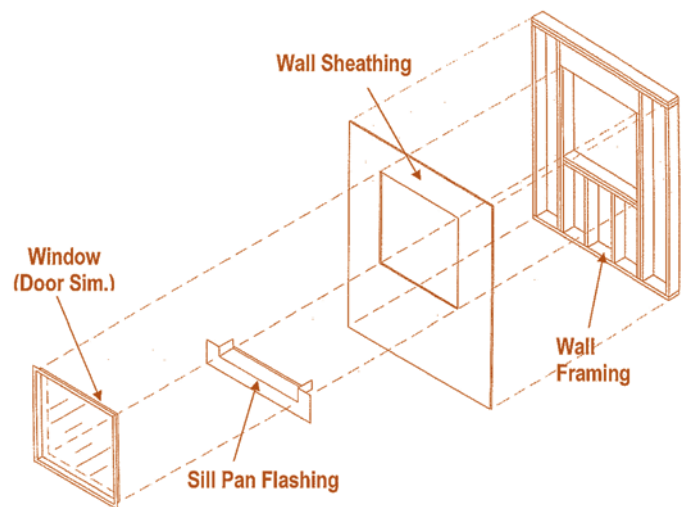

Figure 4 – Sill pan flashing in sheathed wall-framing opening.

Rigid Sheet	1 piece or multiple pieces	Type I
Rigid Sheet	Multiple pieces	Type II
Flexible Membrane	1 piece or multiple pieces	Type III
Combination Systems	Multiple pieces	Type IV
Liquid Membrane	Continuous coating	Type V

(Based on and expanded from ASTM E2112-07, Table 5.)

Table 1 - Types of pan flashing materials.

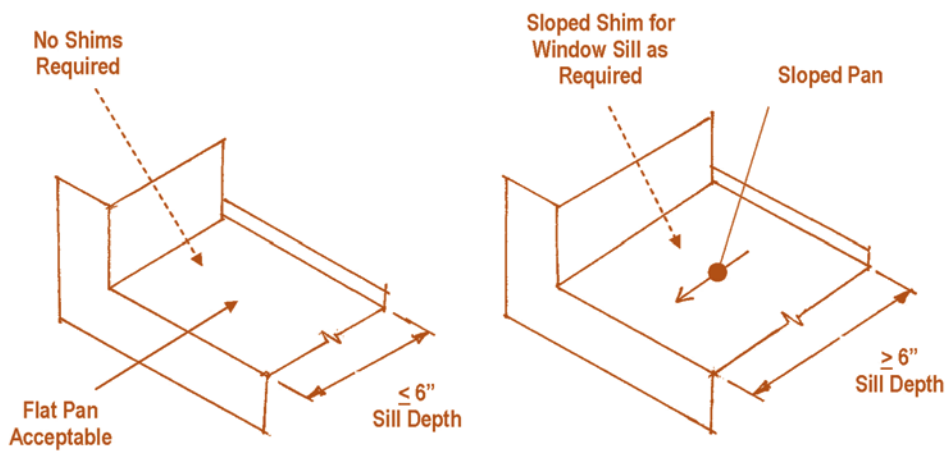

Figure 5 – Flat and sloped sill pans.

SLOPED VS. FLAT SILL PAN

ASTM recommends that the pan portion of the sill pan flashing slope toward the outside in order to promote drainage. It also recognizes the practicality of window and door installations that need to be installed plumb and level (see Figure 5). The bottoms of most modern fenestration units are flat and typically installed to sit on a flat sill rough opening. So a sloped pan would require a sloped shim to support the fenestration unit with a flat sill bottom. The ASTM document recognizes that flat sill pan flashings up to and including a 6-in depth can be effective, so slope is only recommended and not required. When sill pan depths are greater than 6 in, ASTM E2122-07 requires the pan to slope. So sloped shims would also be required for deep fenestration units with flat sill bottoms.

THREE-SIDED PAN WITH FRONT AND SIDE FLANGES

The ASTM E2112-07 and E2266-04 standards define a complete sill pan flashing. Other sill protection techniques that do not incorporate all of the parts of the pan risk leakage. A complete sill pan flashing provides a method for controlling water intrusion from several sources of leaks, including:

1. Water entry around the window/door unit into the rough opening.
2. Water entry through the window/door unit through weather stripping or overtopping sill tracks.
3. Leaks from window/door unit frame joinery.

A complete sill pan flashing assembly can manage the incidental water from these sources (Figure 3). Excessive leakage may overwhelm the capacity of a sill pan.

REAR LEG HEIGHT

ASTM E2112 describes the concept of pan flashing performance related to the capacity of the pan to resist wind-blown rain pressure. The pressure of the wind to drive or draw water “uphill” is resisted by the height of the rear leg of the pan. Appendix A3 of ASTM E2112 lists pressure differentials and the corresponding rear leg heights noted as H1 to prevent leaks overtopping the pan (Figure 6).

Implied but not stated is the opportunity for a low-performance window/door to be backed up with a high-performance sill pan flashing that has a high rear-leg height (Figure 7).

WHAT'S BAD

Along with the good information available for reference concerning sill pan flashings, there still remains and continues to be

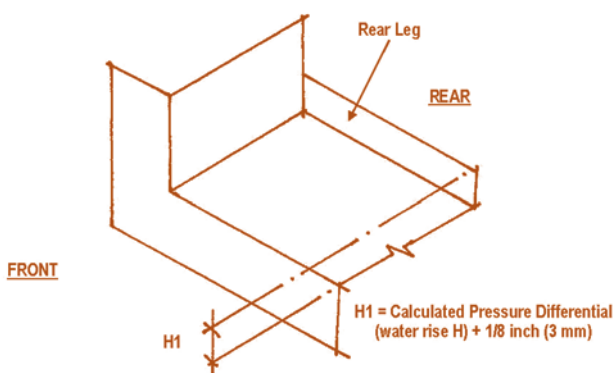

Figure 6 – Sill pan with rear leg height H1 (ASTM E2112-07, Figure A3.1).

some bad news — or, more accurately, news presented badly.

CONFUSING CODE LANGUAGE

The latest IBC requires weather protection, window and door installation instructions, and particular instances of flashing. However, by being both general and specific, the building code is likely to generate confusion for both the design profession and the construction industry. Satisfying code requirements will likely evolve as code-acceptable building plans and detailing practices develop.

The 2006 IBC code, Section 106.1.3, requires that construction documents “include manufacturers’ installation instructions that provide supporting documentation that the proposed penetration and opening details described in the construction documents maintain the weather resistance of the exterior envelope.” Does this mean building plans need to include copies of window and door manufacturers’ cut sheets on the plans? Are manufacturers required to design specific instructions for a specific project? Will reference in the project specifications to the manufacturers’ general recommendations no longer suffice?

MISLEADING STANDARD

In the author’s opinion, ASTM E2112 can be easily reviewed by construction experts to find miscellaneous inconsistencies, some conflicts, and many unevenly developed sections. Examples of compromises made in the original edition that were not revisited between the 2001 edition and the updates to the 2007 edition are noted below.

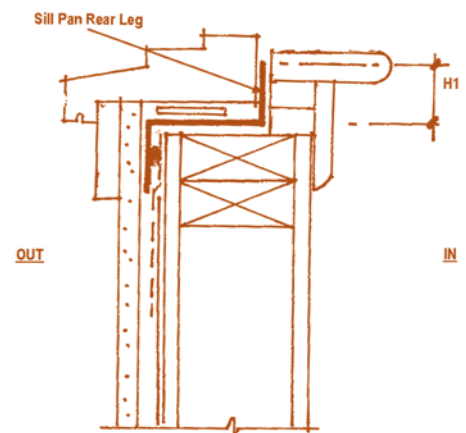

Figure 7 – Sill pan rear leg height, (ASTM E2112-07, Figure A3.2).

SILL PROTECTION FOR DOORS

One traditional and accepted method of providing sill protection at door thresholds (sills) is to bed the door threshold in beads of sealant or in a full, solid bed of sealant. This technique is not fully described and explained in E2112. There are a number of considerations to review before using this technique. Unfortunately, the ASTM E2112 document shows some ineffective water management features regarding the sealants applied at thresholds. The sill pan flashing for doors is problematic (see Figure 8).

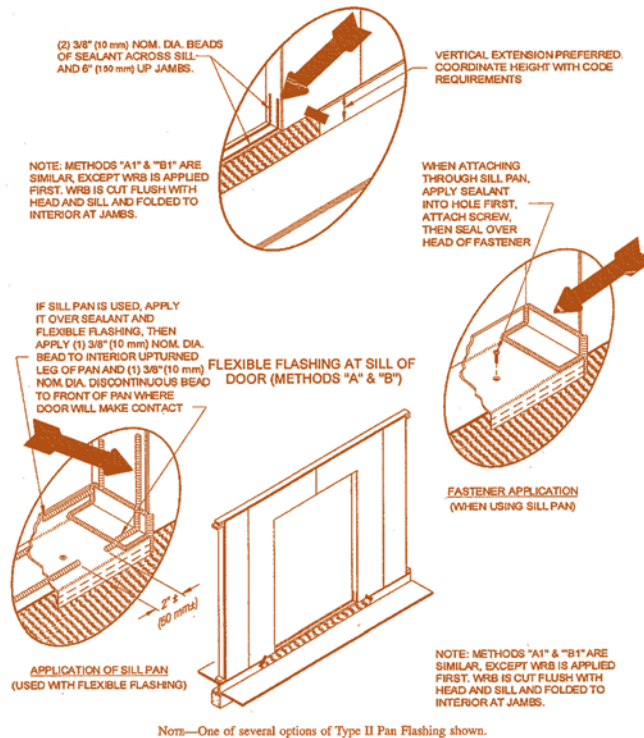

Figure 8 – Sill pan seal at rough opening (excerpt from ASTM E2112-07, Figure 13).

DOOR THRESHOLD SEALANT PROBLEMS

- The sealant must adhere to door-frame and substrate. The type of threshold can vary and needs to be appropriate for sealant use.
- Placement of beads of sealant must be continuous and sufficient to maintain contact with the irregular shapes of the bottom of milled wood and extruded aluminum thresholds.
- Placement of sealant may trap moisture originating behind the line of sealant under the sill if not allowed to drain.
- Placement of sealant may not capture leaks originating from frame corner joinery.
- Doorframes can have thresholds preattached to jambs, which results in the sealant upturn per ASTM at the jamb rough openings left unadhered to the doorframes. The sealant upturn placed at the rough openings and the jamb of the doorframes is spaced away from contact with the sealant.
- Doorframes assembled on site can have the threshold applied after the jambs, which leaves the threshold-to-jamb joint unsealed unless specifically included with flashing instructions.

PIECED SILL PAN

The other sill flashing technique for doors also included in ASTM E2112 as a method for block-frame windows consists of sealing angle pieces to the WRB to form a sill pan (see Figure 9). This technique appears to be an invention proposed for framed membrane drainage walls that was carried over in concept from applications used for storefront subsill installations in surface drainage barrier walls. There are several problems with trying to make the irregular technique work for drainage walls. These include the following pieced subsill flashing technique problems:

- Relies on sealant to glue the subsill angle pieces to the WRB at the jamb. Sealant adhesion is critical, but there are limited sealant products that can bond to both a metal or plastic subsill angle and an asphalt-based or polymeric WRB used at drainage walls.
- The flashing angle relies on a fillet bead of sealant to seal to the rough opening and to the end of the sill pan. The sealant options shown in ASTM E2112, Table A4.1 (Appendix) do not recognize a fillet sealant bead without a bond breaker.
- The top edge of the pieced angle at

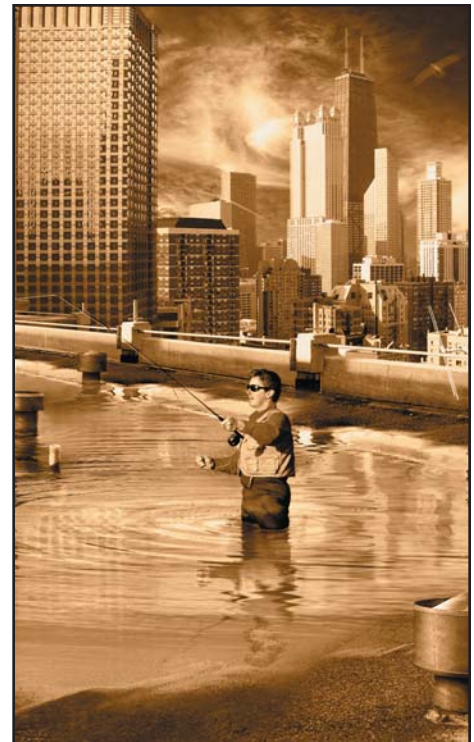

Coal Tar:
First Choice for Flat Roofs

Durapax:
First Choice in Coal Tar

Roofing contractors & specifiers choose Durapax coal tar roofing systems.

- Coal tar roofing provides low cost and long life (25+ years)
- Many coal tar roofs last more than 50 years
- Coal tar's cold flow properties provide self-healing
- Superior technical & customer support
- Delivery you can depend on
- Comprehensive warranties
- UL & FM approved systems

Specify your next flat roof with a Durapax coal tar roofing system.

610.579.9075

Durapax.com

DURAPAX
COAL TAR
COMMERCIAL ROOFING SYSTEMS

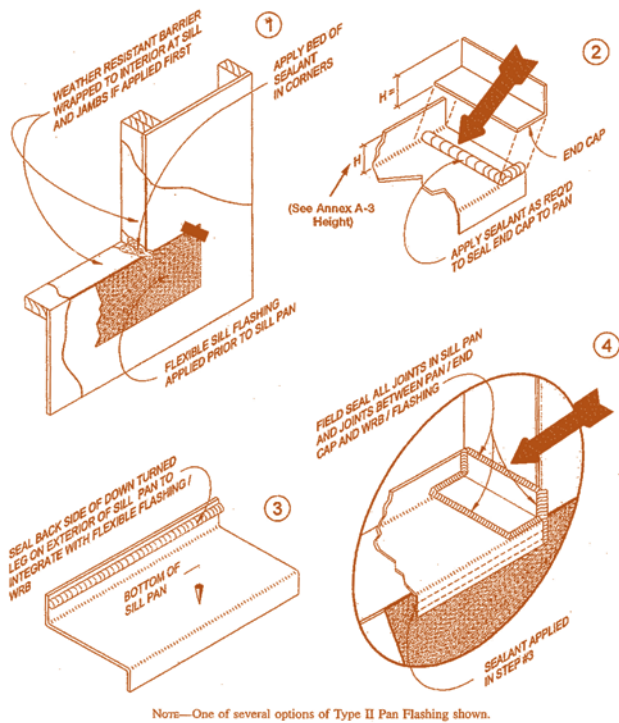

Figure 9 – Pieced sill pan (excerpt from E2112-07, Figure 31).

the jamb is not counterflashed by other flashing or by the WRB turned into the rough opening. The lack of counterflashing breaks one of the principles of good wall waterproofing: Apply waterproofing in shingle lap fashion.

In the author’s opinion, the sill pan flashing methods for doors and windows shown in Figures 8 and 9 are not durable or practical for membrane drainage walls, and the examples should be removed from the ASTM standard.

WHAT’S UGLY

And to complete the references that are good and bad, there is published information that tries to be helpful, but is not presented well or is incomplete. It gets ugly (read “difficult”) when one tries to make sense of it.

BUILDING CODE

The 2006 IBC code Section 1405.3 on flashing includes the requirement that “[f]lashing with projecting flanges shall be installed on both sides and the ends of copings, under sills, and continuously above projecting trim.” Notice the phrase “under

sills.” It has not been established if the IBC is requiring sill pan flashing for windows and doors. It doesn’t appear that code officials are interpreting this strictly for contemporary work. The 2006 Code and Commentary, Vol. 1 by the International Code Council (ICC) provides Figure 1405.3(3), showing a masonry through-wall flashing below a windowsill to illustrate this code section. However, is it a through-wall flashing for the masonry sill, or is it a sill pan flashing for the window? The example in the ICC commentary does not include the illustration of the option of flashing the windowsill to the water-resistant membrane, presumably on the sheathing

shown inboard of the masonry.

It does not appear that the building code has anticipated the difficulty in providing specific details for many of the various types of wall constructions that are available and the many selections of windows and doors that can be installed for exterior walls.

ASTM STANDARD

ASTM E2112 is intended to gather and disseminate practical knowledge. Some of the information in ASTM E2112-07 needs to be reviewed with a high degree of professional knowledge and experience. Some of the examples of problematic presentation of information include those listed below.

SEALANT ADHESION

The sealants listed in the ASTM E2112, Appendix Table A4.2, are rated as “Poor,” “Fair,” and “Good” in terms of adhesion to various construction substrates. However, the results are not uniformly consistent with the author’s experience regarding compatibility and adhesion. For example, the author believes that most silicone and polyurethane sealants perform poorly with asphalt-based WRB and the polyethylene facings of most self-adhering flashing (SAF) products. Specific hybrid polyurethane sealants are marketed for use with proprietary building paper and SAF. The author believes most silicone sealants also perform poorly with wood substrates and especially moist wood, whether becoming moist before or after construction. A few silicones are marketed to be compatible with and adhere to SAF. The benefits of butyl sealant as a bedding sealant for metal and plastic sill pans in concealed locations are not described.

Unfortunately, sealants are a very important component in the performance of bedding sealants and flashings for success-

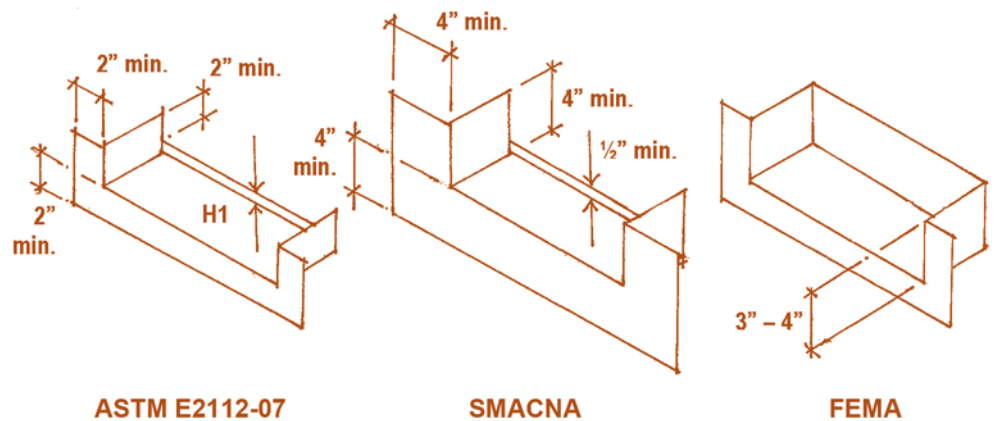

Figure 10 – Sill pan flashing dimensions.

Pan part	ASTM E2112-07	SMACNA, 1968-2003	2007 FEMA Tech Fact Sheet No. 21
Front flange	2 in	As necessary, 4 in at decks	Not specified
End (side) dam	2 in	4 in	3 in to 4 in
Rear leg (back dam)	H1	½-in hook	3 in to 4 in
Side flanges	2 in	4 in	Not specified

Table 2 – Comparison of sill pan flashing dimensions, minimum inches.

ful installation, and ASTM E2112 does not identify the generic sealant types in many places of the standard where sealants are called for. Many details or descriptions of installations do not note that different types of sealants will be needed to complete one assembly. Selection of the wrong sealant can result in the failure of the waterproofing system.

A better reference for sealants is still the *AAMA 850-91 Fenestration Sealants Guide*. Unfortunately, it does not cover sealants used for the building substrates that make up the wall-opening interface with windows and doors.

PAN DIMENSIONS

The dimensions of sill pans shown in Figure A3.2 of the ASTM E2112 Appendix are not consistent with the recommendations from other industry organizations. The 2-in minimum of ASTM E2112-07 will not be adequate for certain applications with combined high winds and rain that are not addressed by the standard (see *Figure 10*).

It is not noted in ASTM, but the flanges of premanufactured sill pans that have limited end dam heights and side flange dimensions can be extended by lapping strips of SAF over the edges to effectively increase the pan dimensions (see *Figure 11*).

AIR SEALS

The performance of a sill pan is similar to the performance of many windows or doors in that the height of the rear leg is related to its resistance to wind-blown rain. Wind-blown rain and wind velocity vary in different geographical regions. The wind velocity generates a differential pressure against a building, wall, window, or door opening. The wind pressure “pushes” (or

“pulls” from the leeward side) rainwater into joints, seams, and seals of windows/doors and the opening perimeter. The wind pressure can drive water upwards. The height of this raised water is known as “water head” or “H,” noted in inches with ASTM E2112. The formula for equating the wind velocity [noted in miles per hour (mph)], to pressure [noted in pound per square foot (psf)], can be found in ASCE-7 and AAMA WSG.1-95. A brief table of wind velocity, pressure, and water rise (H) values is listed in ASTM E2112-07, Table A3.1.

So, for example, AAMA WSD.1-95 uses

a hypothetical 50-mph wind, creating a pressure of 6.4 psf, which can “push” water up 1.23 inches. Therefore, a sill pan flashing’s rear leg would need to be higher (about 1 to 1¼ inches or more) in order to prevent overtopping. But, if the air path into the pan is blocked so that there is no rise in the water being forced into the pan, the pan height can be lowered. One way to accomplish a pan with lower rear leg height is to provide air seals (see *Figure 12*).

The concept of air seals on the interior side between pan and window/door is introduced in ASTM E2112-07. However, it is not

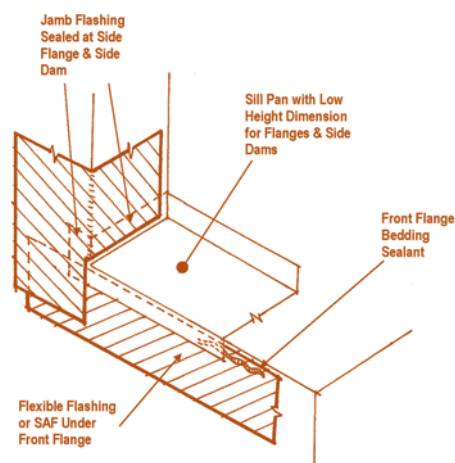

Figure 11 – Increasing pan dimensions with supplemental flashing.



Roof Asset Management Solutions

- Preferred by Professional Users
- Specified by Leading Building Owners
- Proven Roofing Industry Design
- Single or Multiple User Versions
- Robust Reporting Options

Professional Services

- Legacy Data Conversions
- Application Hosting

Serving Roofing Professionals

Digital Facilities Corporation (DFC) is a leading software company dedicated to providing technology tools that help users manage building envelope assets such as commercial roofing systems.

Discover why the leading building owners, property managers, roofing consultants, roofing system installers and product manufacturers rely on DFC for their roof management solutions.



www.digital-facilities.net

(978) 266-1725

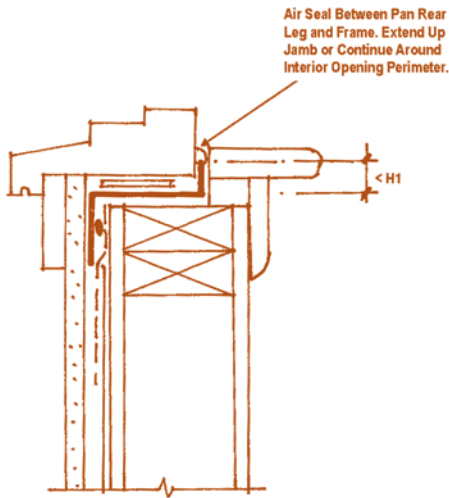

Figure 12 – Air seal reduces rear leg height.

fully explained, described, or illustrated for nonexperts to find useful. In ASTM E2112-07, Appendix Section A3, a small note is added after the discussion of rear leg pan height.

Note A3.1 – Rear leg pan heights can be reduced by the use of continuous air infiltration seals or engineered sealant joints.

An air seal can reduce the height needed for a rear leg on a sill pan to resist a given wind pressure that would otherwise “push” or “pull” wind-blown rain over the top of the pan at the rear. A rear leg sealed to the back of the window frame blocks airflow between sill frame and sill pan and therefore prevents water from flowing into the sill pan and breaching over the top rear leg.

The air seal has to be continuous across the back of the window frame and extend across any gap between the ends of the sill frame and any shim space in the rough opening (See Figures 13 and 14). The air seal application can be addressed by a cou-

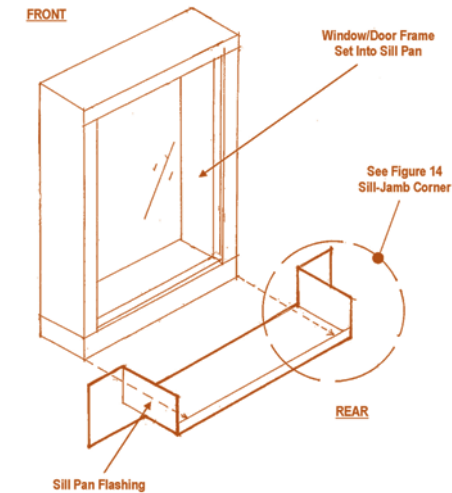

Figure 13 - Windowsill pan with air seal.

ple of methods.

Having a perimeter air seal around the interior (room side) of the window frame will also prevent other air infiltration to reduce energy loss. A method of providing a perimeter air seal is with the use of low-expanding aerosol foam or foam tape. Urethane foams can also seal well to metal frames and most rough opening substrate materials. Foam aerosol and foam tape air seals are included in ASTM E2112, Appendix A1, but the prevention of water leakage is not discussed with the coordination of sill pans.

Additional backer rod and sealant extending up the vertical shim space approximately 6 in will be required to bridge across the shim space gap to effectively create an equivalent raised rear pan leg (Figures 13 and 14). The sealant will need to adhere to the frame jamb and end dam of the pan at the side of the rough opening. Having the pan end dam dimension extend up at least 4 to 6 in can provide a better substrate for the air seal sealant adhesion than wood framing or other nonmetal sheathing material.

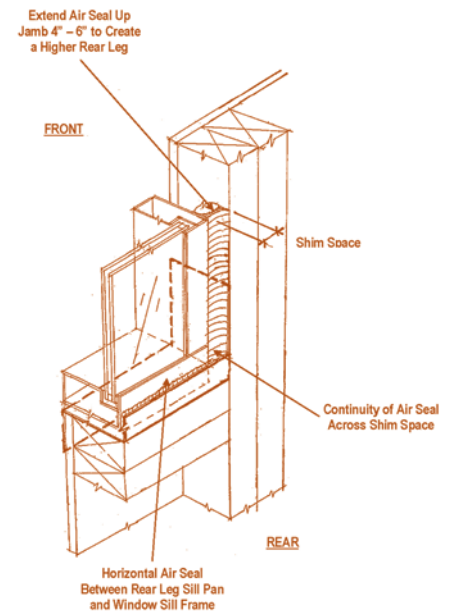

Figure 14 – Windowsill pan with air seal – extended rear leg.

A continuous perimeter air seal provided by low-expanding foam, tape, or sealant also blocks the rise of water in the sill pan. It has the advantage of completing the air-infiltration blockage needed to have a continuous air barrier system as part of the wall assembly (see Figure 15).

With the recommendation that all windows and doors have sill pan flashings, there was no recognition that the sill pan drainage challenges are different with block frames and mounting flange (a/k/a nail-fin or nail-on) frames. The drainage of the sill pan flashing with a block frame unit is described and shown in E2112 with a discontinuous bead of sealant at the forward edge. But the nail-fin installation was not described or shown in the ASTM standard.

In order for a sill pan to drain when using a nail-fin frame, the joint between them needs to open. This can be accomplished in several ways. The perimeter bedding sealant typically applied behind the mounting flange can be omitted along the sill; holes or slots in the sill flange can be drilled or cut (with the manufacturer’s permission); or the sill fin of doors can be ordered to be removed at the factory or field cut (with manufacturer’s permission). A practical method of allowing drainage is to provide intermittent shims between sill flanges and sill pan front flanges. Solid plastic shims set in sealant or strips of SAF through which fasteners are driven can be applied behind the mounting flange (See Figure 16).

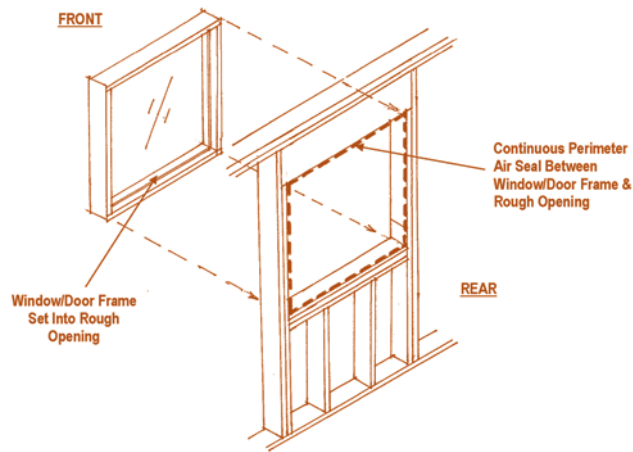

Figure 15 – Continuous air seal at interior window perimeter.

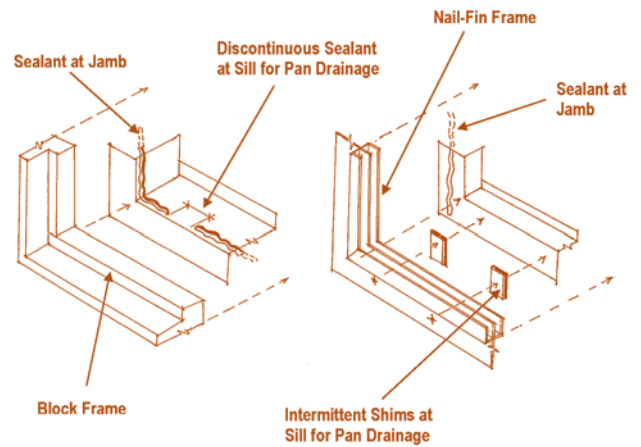



Figure 16 – Block frame and nail-fin frame drainage at sill pan flashing.

CONCLUSION

Sill pan flashing is currently being reconsidered by the construction industry as a necessary backup to windows and doors for low-rise residential and light commercial buildings, although debate continues on whether or not it must be universally required. A sill pan flashing for windows and doors can certainly be included to improve the water-resistance performance of all building types.

Despite the good, the bad, and the ugly, the 2006 IBC and ASTM E2112 can be useful references for important flashing information. Designers, specifiers, and builders can use ASTM E2112 to recognize many important concepts and features when deciding to include a sill pan flashing for a strategy to improve the performance of perimeter wall opening flashings.

Other methods are available besides those that are included or not fully explained by ASTM E2112. Some advice needs to be independently judged and sorted out by knowledgeable professionals. This article is intended to point out some of the positive and negative aspects of the information currently available, from the author's perspective as an insider helping to develop industry standards. The Field Guide sidebar to this paper (Appendix 2) can illustrate how the concepts in ASTM E2112 can be implemented and how sill pan flashings can be incorporated into various types of construction. 

REFERENCES

The author was involved in the CAWM committee that issued CAWM 400-95 and CAWM 410-97. He participated as a member of the ASTM Task Group E6.51.11, which developed ASTM E2112, and wit-

nessed the evolution of the document for ten years. The opinions expressed here are solely the responsibility of the author.

The following references are useful for studying the subject of flashings and sill pans.

BIBLIOGRAPHY

- 2006 International Building Code, International Code Council, Country Club Hills, IL, www.iccsafe.org.
- 2006 International Building Code and Commentary, Vol.1, Country Club Hills, IL, www.iccsafe.org.
- AAMA 711-05, Voluntary Specification for Self-Adhering Flashing Used for Installation of Exterior Wall Fenestration Products, 2005, AAMA Schaumburg, IL, www.aamanet.org.
- AAMA 850-91, *Fenestration Sealants Guide*, 1991, AAMA, Schaumburg, IL, www.astm.org.
- AAMA 2400-02, Standard Practice for Installation of Windows With a Mounting Flange in Stud Frame Construction, 2002, AAMA, Schaumburg, IL, www.astm.org. (This standard was based on CAWM 400-95 but omitted the critical requirement for the vertical edges of the WRB to be sealed along the window jamb.)
- AAMA 2410-99, Standard Practice for Installation of Windows With a Mounting Flange in Stud-Frame Construction, 2002, AAMA, Schaumburg, IL, www.astm.org. (This standard was based on CAWM 410-97.)
- AAMA IM-TM, *Installation Masters Training Manual*, 2000, AAMA, Schaumburg, IL, www.aamanet.org. (This manual was based on the pre-publication work of ASTM E2112-

01. It includes more background information directed towards window installers.)

- AAMA WSG.1-95, *Window Selection Guide*, 1995, AAMA, Schaumburg, IL, www.aamanet.org.
- Architectural Sheet Metal Manual*, 1965 (1st ed.), 1968, 1979, 1987, 1993, 2003 (6th ed.), SMACNA, Chantilly, VA, www.smacna.org.
- ASTM E112-01, Standard Practice for the Installation of Exterior Windows, Doors, and Skylights, 2001, ASTM International, Conshohocken, PA, www.astm.org.
- Robert Bateman, "Designing and Specifying Self-Adhering Flashings for the Window-Wall Interface," *Journal of ASTM International*, Nov./Dec. 2005, Vol. 2, No. 10, www.astm.org.
- Robert Bateman, *Nail-on Windows – Installation and Flashing Procedures for Windows and Sliding Glass Doors*, 1995, DTA, Inc., www.buildersbooks.com.
- Robert Bateman, "Sill Pan Flashing for Block-Frame Windows in Recessed Concrete Openings – Case Studies," *Journal of ASTM International*, March 2008, Vol. 5, No. 3, www.astm.org.
- T.K. Butt, "Window Installation – An Evolving Challenge," November 8, 2004, unpublished manuscript, Interactive Resources, Inc., Pt. Richmond, CA, www.intres.com.
- CAWM 400-95, Standard Practice for Installation of Exterior Windows With Integral Mounting Flange in Wood Construction, 1995, CAWM (defunct; some members reorganized into AAMA, Western Region),

Los Angeles, CA. (See AAMA 2400-02 for similar but not identical standard.)

CAWM 410-97, Standard Practice for Installation of Sliding Glass Doors With Integral Mounting Flange in Wood Construction, 1997, CAWM (defunct; some members reorganized into AAMA, Western Region), Los Angeles, CA. (This standard illustrated different sill pan flashings.)

R.W. LaTona and T.A. Schwartz, "Against the Wall," *Architecture Magazine*, May 1990. www.sgh.com.

Residential Sheet Metal Guidelines, 2001, SMACNA, Chantilly, VA, www.smacna.org.

S.S. Ruggiero, and J.C. Myers, *Design and Construction of Watertight Exterior Building Walls*, 1992, ASTM STP 1107, ASTM International, Conshohocken, PA, www.astm.org.

"Walls - Avoiding Moisture Accumulation in Walls," Form A530A, revised October 2002, APA, Tacoma, WA, www.apawood.org.

"Window and Door Installation - Homebuilders Guide to Coastal Construction," Technical Fact Sheet No. 21, circa 2007, FEMA, www.fema.gov.

FOOTNOTES

1. ASTM E2112-07, Standard Practice for the Installation of Exterior Windows, Doors, and Skylights, 2007, ASTM International, Conshohocken, PA, www.astm.org.
2. ASTM E2266-04, Standard Guide for Design and Construction of Low-Rise Frame Building Wall Systems to Resist Water Intrusion, 2004, ASTM International, Conshohocken, PA, www.astm.org.
3. "Laboratory and Field Evaluation of Pan Flashing/Sill Protection and Water-Resistive Barriers," April 2006, Williams Building Diagnostics - NAHB Research Center, Inc., PATH/HUD, Washington, DC, www.huduser.org. and www.pathnet.org.

EDITOR'S NOTE: This article was first published and presented as part of the Proceedings of the RCI Building Envelope Technology Symposium, October 27-28, 2008, in Atlanta, GA.



With Enduratech™ Coatings, You're Prepared For Anything.

Every job is different: new or existing roof; metal, asphalt or tar; varying climates and weather conditions.

Regardless of the specs, you can trust EnduraTech's™ full line of Premium Coatings and high performance spray foam roofing systems for all your roofing needs.

EnduraTech™ offers you durable, high performance coatings at an exceptional value that meet ENERGY STAR guidelines for improved energy efficiency.

EnduraTech™ means there's comfort on the roof, and science behind the comfort.

EnduraTech™
Premium Coatings

THE SCIENCE
OF COMFORT

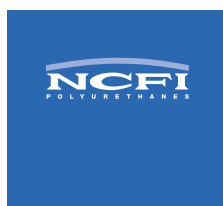

Any way you cut it, Enduratech™ is the best choice. To learn more, call 1-800-346-8229 or visit www.NCFI.com today.

Winner of the EPA Stratospheric Ozone Award.

APPENDIX 2

FIELD GUIDE TO SILL PAN FLASHING

There are various types and shapes of sill protection and different methods of constructing and installing a sill pan flashing for windows and doors. The Field Guide shows some of the examples of the types of sill pan flashings used for windows and doors in various types of wall openings and combined with different wall claddings.

Field Guide Notes:

- **Concealed** – refers to a sill pan that is under the wall cladding and integrated with a drainage-type water-resistive barrier (WRB)
- **Direct Drain** – refers to a sill pan that drains under the window/door immediately to the outside of the exterior wall cladding and can be used with barrier walls or drainage walls
- **GSM** – galvanized sheet metal
- **SAF** – self-adhering flashing
- **Type I, II, III, IV** – refers to ASTM E2112-07, Table 5
- **Type V** – refers to Table I liquid membrane coating (Appendix I)
- **WRB** – water-resistive barrier



1: Type III – SAF pan – concealed for nail-fin window in recessed metal siding opening.



2: Type I – GSM pan – direct drain for block-frame window in recessed stucco opening.



(Left) 3: Type I – GSM pan – concealed, for block-frame window in recessed stucco opening.



4: Type I – Aluminum pan and sill cover – direct drain for block-frame window in recessed stucco opening.



5: Type I – GSM pan – concealed, for block-frame door in flush stucco opening and elastomeric deck.



6: Type I – GSM pan – direct drain for block-frame window in concrete opening.

APPENDIX 2 (CONTINUED)



7: Type I – GSM pan – Concealed, for block-frame window in recessed stucco opening. Type III SAF sill pan under the metal pan.

(Below) 8: Type III – SAF pan – concealed, for block-frame window in recessed stucco opening.



9: Type III – GSM pan – direct drain for block-frame window in masonry opening.



(Left) 1: Type IV – Stainless steel pan corners and separate rear leg with Neoprene sheet membrane center section and urethane deck coating. Block-frame sliding glass door in recessed stucco opening.



11: Type III – SAF pan – concealed for block-frame window in metal panel cladding. Aluminum sill cover protection over pan flashing.



13: Type III – SAF pan – concealed, for block-frame window in recessed stucco opening. Aluminum sill cover protection.



12: Type III – SAF pan – concealed for block-frame window in brick veneer cladding. Aluminum sill cover protection.



14: Type V – Liquid-applied sill protection to flush opening. A Type I – multiple pieces pan will go over the sill.

Robert Bateman

Robert Bateman has worked as an architect for several A/E firms over the past 25 years and currently practices as a staff consultant specializing in waterproofing the exterior building envelope. He has been involved in forensic investigation and repair design for residential, multifamily, commercial, and institutional buildings, including litigation support and expert witness testimony. Bateman has a B-1 general building contractor license from California and has been certified as a building inspector and plans examiner by the International Code Council. He has actively participated with standards development for ASTM E2112-01 and the details and appendices on sill pan flashing for ASTM E2112-07. Robert has presented at national building and design organizations and trade shows, including RCI's Affiliated SoCal Chapter. He has published peer-reviewed papers for ASTM and BETEC on building envelope detailing and window flashing. Bateman is the author of *Nail-on Windows – Installation Procedures for Windows and Sliding Glass Doors*, published in 1995.

