

# BUILDING ENVELOPE TECHNOLOGY SYMPOSIUM

## HIDDEN HOLES IN WOOD-FRAMED BALCONY WATERPROOFING

**ROCCO ROMERO, RA**

*WISS, JANNEY, ELSTNER ASSOCIATES, INC.*

960 South Harney St., Seattle, Washington 98108

Phone: 206-622-1441 • Fax: 206-622-0701 • E-mail: [rromero@wje.com](mailto:rromero@wje.com)



**RCL, Inc.®**

## ABSTRACT

Balconies are a standard component of many multistory apartment and condominium buildings and provide a means to extend the living space to the outdoors. However, inadequately detailed deck-to-wall interfaces and railing post penetrations often cause water intrusion into the tenant spaces of the building and substantial distress to the balcony structure. When designing balcony waterproofing assemblies, supplemental sheet metal flashing components integrated with both the waterproofing membrane and the weather-resistant barrier of the cladding system should be considered to provide long-term waterproof performance. Several case studies of balcony repair projects will be presented, assessing the as-built construction, subsequent water intrusion, resulting distress, and investigation and repair methodology.

## SPEAKER

*ROCCO ROMERO, RA — WISS, JANNEY, ELSTNER ASSOCIATES, INC.*

Rocco C. Romero is a registered architect with over 20 years of experience in the forensic investigation of hundreds of building envelope and façade systems and specializes in investigation, assessment, and repair design for roofing, waterproofing, and cladding systems in both contemporary and vintage structures. He provides consulting services to owners, architects, and general contractors related to the design and constructibility of new and retrofit building envelope systems. Romero also provides litigation and expert witness support services for existing buildings.

# HIDDEN HOLES IN WOOD-FRAMED BALCONY WATERPROOFING

Balconies offer an important benefit of living in a multistory apartment and condominium building by extending usable living space to the outdoors. In some cases, exterior elevated walkways act as corridors to provide access for residents to their units and include stairways that are also exposed to the elements. The desirable exterior exposure of balconies and corridors also creates a challenge in controlling water leakage. Poorly detailed and constructed transitions, interfaces, and penetrations often lead to water intrusion into the occupied tenant spaces of the building and may also result in substantial distress to the building's exterior walls and structure.

In wood-framed balcony and exterior elevated walkway construction, detailing at transitions, interfaces, and penetrations is often the most challenging and critical aspect of waterproofing system design. In particular, inadequate attention to the design of wall flashing, guardrail wall and exterior wall integration, railing post anchorage, and deck slope for proper drainage can lead to severe deterioration of the supporting structure. Remedies to mitigate problems often require removal of both exterior and interior building components, including cladding, architectural paving, door thresholds, soffits, ceilings, and interior finishes and can be difficult and expensive but are often necessary to gain access to inspect and repair leaking assemblies.

When designing wood-framed balcony and exterior elevated walkway waterproofing assemblies, proper detailing of supplemental sheet metal flashing components integrated with both the waterproofing membrane and adjacent cladding systems is essential to successful long-term performance of waterproofing systems. Design should include systems that shed water and, most important, can be adapted to unique conditions.

## BACKGROUND

The goals of any waterproofing system are to minimize water leakage, manage the flow of water, and provide some level of redundancy within the system. Numerous approaches and membrane options can be

implemented in a balcony or exterior elevated walkway waterproofing design. In wood-deck construction, the components usually consist of (from bottom to top) balcony post or wall supports, wood joists and framing, exterior-grade plywood or oriented strand board deck substrate, and waterproofing membrane or deck coating, with a railing system/guard wall incorporated at the perimeter edge. In some cases, a wall partition bisects a deck to segregate the deck into individual semiprivate areas. On larger decks or decks with raised perimeter curbs, drains can be incorporated into the waterproofing assembly. In many cases, however, the deck slopes to drain away from the building to the outer edge of the deck. At the underside of the decks, a vented soffit typically encloses the exterior joist cavities.

Where decks are constructed over occupied living areas, insulation is usually installed in the joist cavities.

Exposed pedestrian traffic-bearing membranes generally consist of a multilayered, fluid-applied deck coating system or single-ply waterproofing membrane system. In some cases, fluid-applied multilayered elastomeric systems have fabric reinforcing that can be used to prestrip deck board joints and also to reinforce the coating transition to the horizontal leg of supplemental sheet metal flashings. Aggregate (i.e., silica) is typically broadcast in the top coat to provide a level of slip resistance to the membrane surface. Fluid-applied membranes are spread directly on the deck substrate with squeegees and trowels or spray-applied to create a monolithic, seamless application.

Flexible, single-ply membranes are often referred to as "vinyl" membranes. They are composed of polyvinyl chloride (PVC), which consists of carbon, hydrogen, and chlorine. PVC single-ply membranes are defined as a thermoplastic, which essentially means that the material can change



Figure 1



Figure 2



**Figure 3**

from a solid state to a semisolid state with the application of adequate heat, enabling the membrane to be overlapped and fused through heat welding to create a watertight seam. At the overlapped seam that is to be heat welded, the process locally turns the membrane from a solid state into a semisolid state, thus fusing the membrane together. Once heat is removed, the membrane rapidly cools, returning to a solid state, and is thus fused. The membrane is then typically adhered to the deck with proprietary adhesives.

#### **Leakage Investigation**

When the integrity of the waterproofing membrane system is compromised, there can be obvious signs of water intrusion and deterioration of the deck structure, such as water stains on soffits directly below the deck and “soft spots” on the walking area of the deck surface. However, substantial damage to the structure is sometimes hidden beneath the cladding (*Figures 1 and 2*).

When conducting a leakage investigation, sources of water leakage in the membrane are sometimes obvious but more often, are not. As an example of a more obvious source of water

at approximately 6-in on-center intervals. It was at these penetrations that leakage was occurring.

#### **Railing Base Plate Anchor Penetrations**

In other cases, the sources of the water leakage are not as obvious. When railings are located at the deck perimeter, the base plates for the railing systems are often attached through the membrane and horizontal deck into the framing below. Because decks are often sloped for drainage to the outside edge (opposite the main exterior building wall), the railing anchors are located in the direct path of water flow. In addition, railing base plates installed on a sloped deck are usually not fabricated to accommodate the slope of the deck; thus the base plates require shimming, resulting in an additional gap between the base plate and membrane where water can enter the anchor bolt holes. Anchors can be installed with plastic caps, sealing washers, and sealant to cover the exposed anchor head; however, due to the anchor penetrations through the deck, the interface between the railing base plate and deck waterproofing is most critical. Although a sealant fillet bead is often applied at this juncture, water that infiltrates past this single line of defense enters under the railing base plate and can leak into the deck construction at the anchor bolts.

leakage, a single-ply membrane had laps located transverse and sometimes parallel to the slope of the deck. It was readily determined that in an apparent attempt to protect the seams from foot traffic, metal cover strips (similar to termination bars) were fastened through the horizontal surface of the membrane (*Figure 3*) into the plywood substrate, resulting in membrane penetrations



**Figure 4**



Figure 5

### Guardrail Walls

Where guardrail walls are present, investigating from the top to bottom is the preferred approach when trying to find the source of water leakage. Guardrail walls are often used in conjunction with perimeter railing systems to provide a level of privacy at adjoining decks. Water leakage can often be traced to the interface of these walls with the main exterior building wall. Wood caps and sheet metal copings that do not incorporate sheet metal saddles properly integrated with the weather-resistive barrier of the adjacent building cladding leave a gap at the transition to the main building wall that can be a source of water intrusion. If water enters the guardrail wall assembly and infiltrates past the weather-resistive barrier to the underlying sheathing layer, this infiltrating water can pass behind the base-of-wall membrane flashing, resulting in leakage. By starting at the top and removing the guardrail wall cap and cladding, water stain patterns or sheathing deterioration can be revealed that can help determine the source(s) of water infiltration.

Base-of-wall flashings are often covered by the subsequent cladding of the guardrail walls. Removal of the cladding and weather-resistive barrier (building paper) can provide initial indications to the origins of the water intrusion source. For instance, water stains on sheathing that originate near the base of the wall are signs of failed flashing (Figure 4) as depicted by water wicking upward at the sheathing.

Sheet metal deck-to-wall transition



Figure 6

flashings are commonly used in fluid-applied elastomeric membrane applications. Where gaps or discontinuities occur in transitions between flashing components (Figures 5 and 6), water intrusion can occur. These discontinuities are often the result of lack of coordination in work performed by different trades, such as the waterproofing subcontractor installing the membrane flashing on the outside edge of the deck and the siding subcontractor installing the drip flashing at the adjacent wood fascia trim.

Coordination of the installation and sequencing of work are important components of quality control and are critical to a

complete and successful membrane system. At sheet metal base-of-wall flashings, the metal work should be installed in sequence, following the slope of the deck from the low point to high point. Laps should be installed in a shingled manner so that the flow of water sheds over the laps. The waterproofing membrane should be installed prior to the cladding so that the membrane can be continuously applied vertically onto the sheet metal base-of-wall flashing, providing an additional seal at the sheet metal laps. Failure to follow this sequence can result in gaps at the flashing laps (Figures 7 and 8) and subsequent water leakage.

Figure 7



Figure 8



### Door Thresholds

Doorways that provide access to balconies and exterior elevated walkways are a unique challenge to waterproofing membrane installations. At these locations, deck surfaces should always slope away from door thresholds. Door thresholds that are at the same elevation as the deck surface are prone to water entry from wind-driven rain, as the only barrier to inhibit water entry is the weather stripping at the bottom of the door. While thresholds provide a termination point that separates the waterproofing from interior floor finishes, threshold anchors that penetrate the waterproofing membrane are direct paths for leakage into the wood deck construction. In addition, adjacent base-of-wall flashings often terminate at the jambs of the doorway's rough framed opening, often without supplemental flashing to make the doorway threshold waterproof. Good design practice is to have the interior subfloor slightly higher than the surface of the exterior deck to create a change-in-elevation plane that helps obstruct the flow of wind-blown water into the interior. This practice, in combination with a fully soldered and flanged sheet metal door pan that is integrated with the adjacent sheet metal base-of-wall flashings, helps provide a continuous substrate for waterproofing application. The elevation

### Covered Membranes – Concrete Wearing Course

Elevated exterior walkways that provide egress to individual apartment units are often designed with a concrete wearing course (topping) placed over a membrane as a part of the fire-rated construction. This “sandwich,” or covered type of membrane installation, in which the membrane is installed between the deck and the concrete topping, can use numerous types of proprietary membrane systems, including self-adhering preformed sheets and hot- or cold-fluid-applied rubberized asphalt membranes with integral fabric reinforcing. While these types of membranes are not designed for exposure to ultraviolet light or foot traffic, they can provide long-term service if properly designed and installed. Membrane systems that are intended solely for roofing applications should not be used for decks and walkways.

Drainage composites can be used for water management and for facilitating drainage of water in covered membrane systems, as they create a space between the underside of the topping and the membrane and help expedite drainage of the membrane surface. Heavy organic growth at concrete topping construction joints is usually an indication that water is not draining freely from the underlying membrane layer.

change of the interior floor height at thresholds should conform to applicable local codes, ordinances, and federal accessibility guidelines.

Accumulation of water at the membrane level can result in freeze-thaw deterioration of the concrete topping in some northern climates.

At the outside edges of the walkway, L-shaped galvanized metal edge strips are sometimes used as a permanent border of the deck construction to aid in the initial placement of the concrete wearing course (Figure 9). Problems can arise, however, when these edge strips are incorporated as part of the waterproofing membrane system.

In a covered membrane application, the membrane cannot be exposed at the outside edge of the deck construction where the membrane terminates. If the waterproofing membrane is sealed to the top of the horizontal leg of the edge metal, water cannot readily exit the waterproofing membrane layer and can result in corrosion of the edge metal. Although a properly installed membrane can withstand the hydrostatic pressure of the trapped water, water can infiltrate underneath the membrane if the membrane is not well bonded to the metal flashing, causing localized water leakage



Figure 9



**Figure 10**

and deterioration of the deck construction (Figure 10). In addition, long-term membrane bond to the edge metal can be affected by the corrosion on the edge metal.

Sheet metal inside and outside corner flashings are most critical in a covered waterproofing application. Unlike an exposed membrane system, where there is access to the flashing to trace leaks and perform repairs, investigating and repairing leaks in a covered system can be difficult and expensive. Partial removal of the concrete wearing course presents other issues, such as causing additional damage to the existing membrane, difficulty in installing proper tie-ins for the repaired area to the existing membrane, and matching the texture and color of repairs to the existing con-

crete finish. Therefore, if the area to be repaired is a walkway or small-to-midsize balcony deck, the economical decision is usually to remove and replace the entire waterproofing membrane system and concrete topping.

At corners where the application of sheet metal flashing components requires them to be cut and pieced together, laps and discontinuities must be completely sealed. Sheet metal flashing at corners are often poorly field-fabricated, creating holes at the apex of the cuts (Figures 11 and 12). Discontinuities in the sheet metal flashing, coupled with unsealed laps, can result in water intrusion under the membrane, contributing to the decay and deterioration of the deck structure.

### Challenges of Proper Flashing Integration

Successful long-term performance of a membrane system is the result of proper design of the waterproofing system, including the selection of appropriate and compatible materials and flashing, the skillful implementation by the applicator to achieve a quality installation, and maintenance to the system where applicable. While the field of the membrane is generally predictable and well detailed by the membrane manu-

facturer, the transition of the membrane at terminations and transitions can be unique and should be tailored to each project.

In order for the designer, contractor, and owner to understand and develop realistic project expectations, details should be prepared that illustrate the profiles of the specific flashing components that are anticipated. Schematic plans of balconies and walkways where specific flashings are required should be part of the contract documents, followed by shop-drawing submittals prepared by the contractor for each flashing type and condition.

### Mock-ups

Field mock-ups are essential and should be a part of all membrane installations. It should be understood that field conditions will likely require that components be altered to provide a better fit and to ensure watertightness; thus, modifications to field mock-ups are useful in refining details prior to overall installation. Field mock-ups are an important part of the construction process and provide an opportunity to resolve unforeseen conditions prior to fabrication of flashing components for the whole project. Mock-ups should be installed in the field on actual decks that will be waterproofed and the work performed by the actual trades and specific personnel who will be performing the work, as well as sequenced with the adjacent cladding construction. The reviewed and accepted mock-ups help establish the quality of construction required for the project and define the expectations of all parties.

### Deck Slope

Adequate slope of walkways and decks at the membrane layer is important to the success of a waterproofing membrane system. Where decks slope in one direction to



**Figure 11**



**Figure 12**

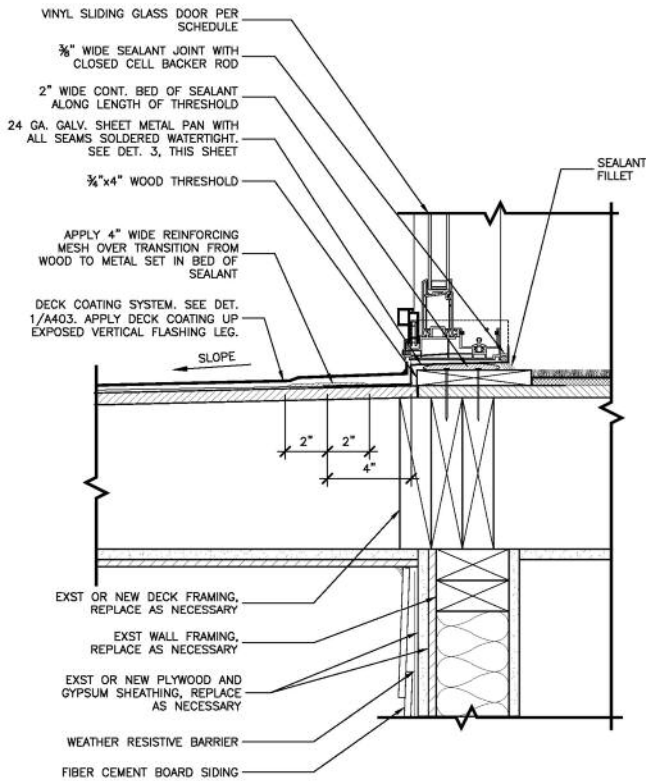

Figure 13

the outside edge for drainage, slope at the membrane level should range between 1/8 in to 1/4 in per ft minimum or as required by local codes. In general, the more slope the better, and the design should accommodate for frame shrinkage as well.

An additional design consideration is that floor joists are often cantilevered from the floor framing within the building interior; thus, if the decks are constructed with a low slope, the slope is often substantially diminished once the gypsum flooring is placed at the building interior. The weight of the gypsum flooring can cause the interior floor joists to deflect, causing the outer ends of the joists at the balconies to slightly rise upward. Therefore, adding additional deck slope during the original design and construction process should be considered to help accommodate for this condition.

### Metal Flashing Selection and Fabrication

In wood-framed construction, sheet metal flashings should be considered at all transitions to provide a continuous substrate for membrane application and adhesion. The metal flashing material will vary, depending on the type of membrane that is to be applied. Galvanized flashing is a serviceable choice for fluid-applied elastomeric membrane applications where soldering of

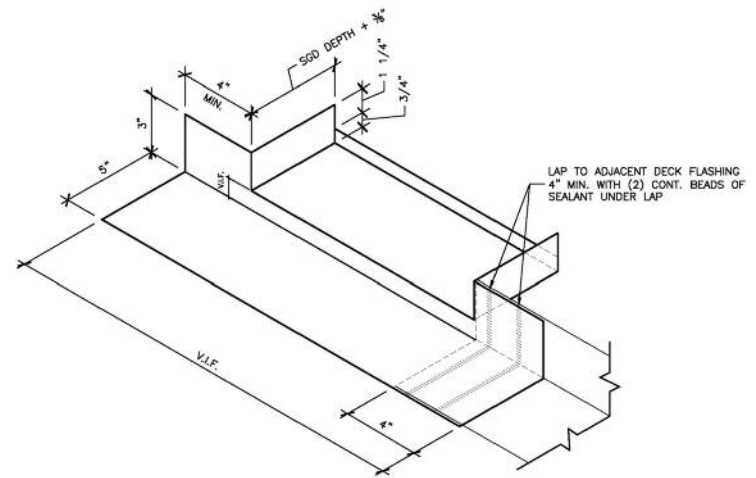

Figure 14

the metal work is required. Elastomeric membranes bond well to galvanized sheet metal if the surface is properly cleaned, free from oily residue, and primed as required by the membrane manufacturer.

Prefinished sheet metal should be avoided if soldering is required. Stainless steel should also be avoided, as elastomeric membranes do not bond as well to stainless steel. In single-ply PVC membrane installations, PVC-coated sheet metal is the optimum choice for flashing material to be incorporated into the membrane design. When heated to a specific temperature range, the single-ply PVC membrane can be heat welded and fused to the PVC-coated sheet metal. PVC-coated sheet metal can be provided as a part of the membrane system by the membrane manufacturer. Since dimensions in deck construction can differ slightly from deck to deck, all conditions requiring flashing should be measured by the contractor in the field prior to fabrication.

### Door Pans

Where doors access the decks, the doorway thresholds should be above the deck surface as much as allowed by governing codes. Waterproofing membrane installations should incorporate sheet metal door

panels that are integrated with the waterproofing membrane and adjacent sheet metal flashing components (Figures 13 and 14). Where the door sets in the horizontal portion of the door pan, the pan should not be penetrated by threshold fasteners, as this defeats the purpose of installing a supplemental, watertight flashing component. Side laps in adjacent sheet metal flashing components must be adequately sealed with several beads of sealant that are transverse to the laps to make the flashing watertight prior to application of the waterproofing membrane. Sealant used in metal work that may be in contact with the waterproofing membrane must be compatible with the membrane.

### Flashing Coordination

Outside edge flashings should not inhibit the flow of water draining from the deck. If the deck is sloped for drainage to the outside edge of the deck, the exterior



Figure 15



**Figure 16**

edge of the wood deck should be sufficiently planed so that the installed metal-drip flashing is slightly recessed and the membrane application does not build up at the transition to the deck-edge metal and inhibit drainage (Figure 15). If this condition is not sufficiently addressed, water may collect on the membrane at the deck edge. Sheet metal flashings should always be installed in shingle fashion, in a manner that sheds the flow of water so that it is not directed into laps.

Base-of-wall flashing should be installed to a height of 6 in minimum, with laps sealed with several beads of sealant applied transverse to the lap. The flashing should be installed well in advance of the

installation of the weather-resistive barrier on the building walls (Figure 16). This sequencing allows the waterproofing membrane to be applied onto the vertical portion of the metal flashing, thus providing a redundant seal at the flashing laps. This sequencing can be tricky, as it requires coordination of the work of other trades that are likely on site performing work at the same time.

### Transition Components

Deficiencies in transition components are one of the main sources of water intrusion in wood-

deck waterproofing systems. Base-of-wall flashing at inside and outside corners, post boots, and outside edge deck terminations at walls are critical components that are also complex; these components must be designed to integrate with adjacent metal flashing as well as to provide flanges for proper integration with the building's weather-resistive barrier. To provide better long-term performance, these flashings should be constructed as one-component pieces, with all seams soldered watertight. Since these components are usually complex, they require fabrication from several sheet metal pieces that are tabbed together and soldered watertight at the seams. Though fabricated from several pieces, the result is a one-component, complex flashing segment. Careful field measurement of as-built conditions is required prior to fabrication so that the pieces fit together well in the field.

At the outside edge of balconies, one-component sheet metal flashings (Figure 17) provide a watertight transition at this critical area. At deck-to-wall transitions on outside building corners, flanges should be provided for integration with the waterproofing membrane and for integration with the weather-resistive barrier on the building wall (Figure 18). This detail helps create a watertight transition at the corner, which is otherwise susceptible to leakage.

At post locations that penetrate through deck framing to support upper decks, boot flashings should be fabricated and installed as separate one-component sheet metal



**Figure 17**



**Figure 18**

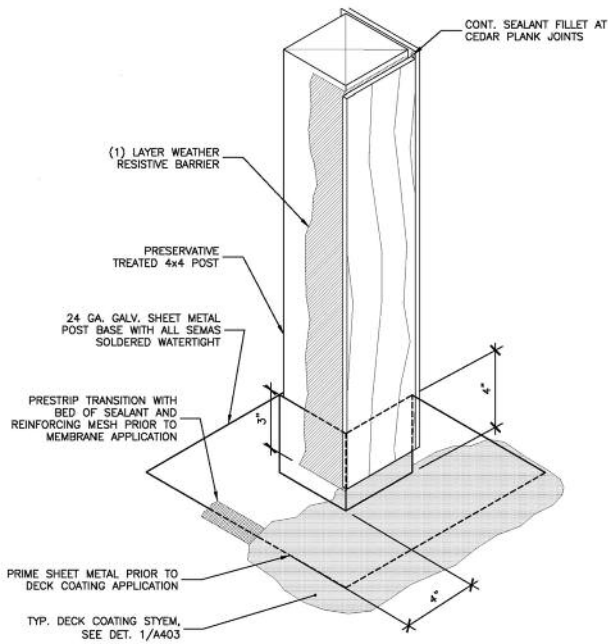

Figure 19a

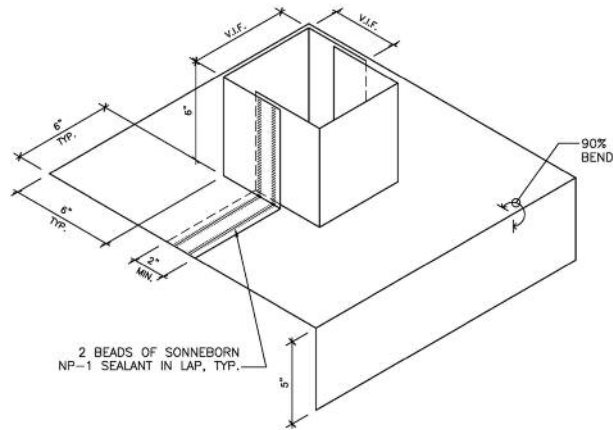

Figure 19b

flashings that fit together around the base of the post (Figure 19). As a part of proper installation sequencing, the post should be wrapped with a weather-resistant barrier that laps over the vertical leg of the sheet metal boot flashing and the post subsequently clad with wood siding. This detailing allows the membrane to have a consistent substrate at the horizontal-to-vertical transition. In addition, if water enters the post cladding, the weather-resistant barrier will direct the water over the metal boot flashing and safely onto the surface of the deck waterproofing membrane.

### Vertical-Mounted Railing Base Plates

Although railings are a necessary part of balcony and walkway construction, design of railing attachments is sometimes over-



Figure 20

looked and left to chance. Railing attachment is often not detailed in the construction documents, and it is left up to the fabricator/contractor to decide the preferred method of installation. Thus, a well-installed waterproofing membrane might be penetrated by railing base-plate anchors at a critical location where the slope of the balcony directs water for drainage. Railing base-plate attachment through the waterproof membrane at the horizontal deck surface

should be avoided since it is difficult to make the anchor penetrations watertight. Even if watertight initially, sealants used at the base plates will require routine maintenance. A more serviceable approach to railing attachment is to design the deck for railing post anchorage at the vertical edge of the deck (Figure 20). Anchorage of the railing at this location does not compromise the integrity of the waterproofing membrane system.

Unlike the horizontal base-plate application where anchor bolts are subject to water directed by the slope of the deck, drip flashing can be installed directly above vertically oriented railing base-plate connections to help direct water away from the anchor bolts. In repair projects, it is typically not economically feasible to modify exist-

ing railing posts and retrofit them with new vertically oriented base plates; thus, new railings are required. Additional framing and blocking is generally also required at the deck perimeter if the railings were not originally designed for anchorage through the fascia.

### CONCLUSIONS

The successful performance of a wood-deck waterproofing membrane system is the result of proper waterproofing system selection, membrane and flashing design, installation of interface components, and coordination with the work of other building trades. In order for the designer, contractor, and owner to understand and develop realistic project expectations, details should be developed that illustrate the profiles of the specific flashing components that are anticipated. Mock-ups are essential and should be installed in the field on decks that will be waterproofed, with the work performed by the specific personnel that will be performing the work on the project and properly sequenced with the adjacent cladding construction. The reviewed and accepted mock-ups help provide the required learning curve and establish the quality of construction required for the project, which subsequently defines the expectations of all parties. 

### REFERENCES

- Thermoplastic Subcommittee of SPRI, "The ABCs of PVC Roof Membranes," *Roofing, Siding, Insulation*, January 2001.