

# Engineered Methods for Reroofing Metal Airplane Hangars

By Charlie Smith

In the 1970s and 1980s, metal became a practical option for constructing commercial and industrial buildings, as well as many types of storage facilities, from simple backyard sheds to large warehouses.

Some of those buildings are in need of repair to remain functional. Leaking roofs caused by age, damage, or other issues have become a common problem for building owners, creating an opportunity for consultants and roofers alike.

## LAFAYETTE REGIONAL AIRPORT

Metal buildings remain a popular choice for airplane hangars, small and large. The Lafayette Regional Airport in Lafayette, LA, is home to nearly three dozen hangars, all of which are inspected either annually or semiannually. The man charged with inspecting the hangars (some more than 40 years old) is Ian Brown, project manager at MBSB Group, in Lafayette (Figure 1). Over the past dozen years, Ian has witnessed predictable roof failures on quite a few of these structures.

"I've been with MBSB for 16 years," Brown says, "and 12 of those 16 have been dedicated to helping Lafayette Regional Airport inspect and maintain its facilities. Many of these facilities are aging metal buildings with 26-gauge, exposed fastener R-panel roofs." R-panels, a low-profile 36-inch metal roofing (or wall) panel that can be installed over open framing or a solid substrate, remain the standard option for large metal buildings. They are chosen for their low cost and because the wide panels allow installers to cover the building quicker than with narrower panels.

Many times, the older roofs begin to leak at the end laps and where fasteners are

installed. Thermal movement helps to elongate the holes where the screws penetrate the panels. Louisiana also receives some of the most intense sun and torrential rains in North America, both of which accelerate aging of all roofing materials.

"Structurally, the buildings remain in good shape," says Brown, "and by employing several different metal retrofit systems, we've been able to avoid the expense of tearing down a building and rebuilding a replacement. We've re-covered more than a dozen hangars and assorted outbuildings over the past 12 years."

## EVOLUTION OF THE RE-COVER

"Our job here is to provide long-term value to our client, and our client does not want short-term fixes," Brown says. "Many of these exposed fastener systems have lasted 40 years. If it were not for the end laps and the way these panels were through-fastened to the structure, they would have lasted a

lot longer. In our view, coatings or single-ply re-covers are short-term solutions when compared to a metal roof that can last 50-plus years. We re-cover with full-length, structural standing-seam panels that are attached back to the structure."



Figure 1 – Ian Brown going up for a roof inspection.

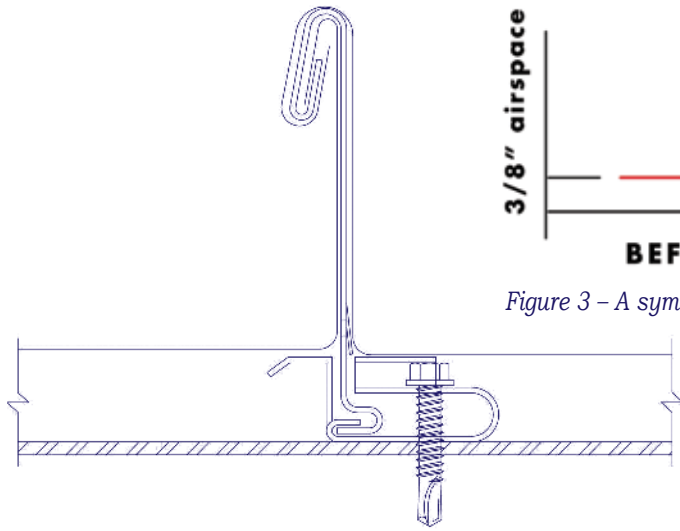

Figure 2 – A standard double-lock, standing-seam metal roofing panel.

During the past 12 years, the systems have evolved as improvements have developed, but the basic idea is the same: leave the old roof in place, use full-length panels to eliminate the end laps, and attach the new roof to the structure.

“When we first started re-covering buildings at the airport, we used a notched sub-purlin attached through the old roof into the purlin below and a continuous-length, 2- or 3-in.-tall, vertical-rib, 180-degree, double-folded, structural standing-seam panel,”

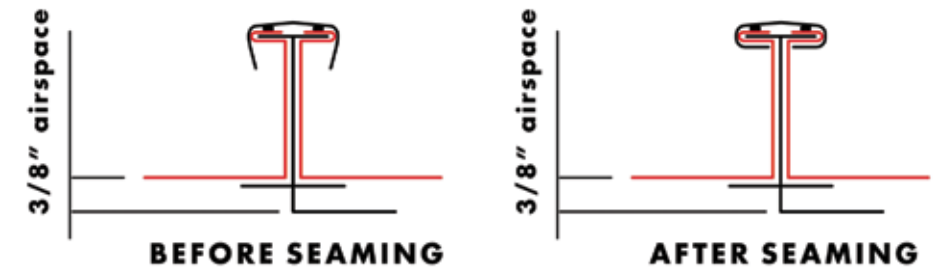

Figure 3 – A symmetrical standing-seam roofing panel.

panels that run full length from top to bottom. This system will have no horizontal lap joints and no exposed fasteners to leak. The 180-degree double-folded standing seams provide the best wind uplift and watertightness available.

“Re-cover is the best option for our tenants because it provides the least disruption to their operation and offers an opportunity for us to add insulation between the new and old roof.”

There are other significant advantages to re-covering. While all structures should be inspected by a qualified design professional prior to doing any work of this

nature, re-covering over an R-panel does not alter the structural diaphragm, since the exposed fastener panel that remains in place is an integral part of the structure. Also, the system weighs less than 3 pounds per foot, so it falls within the guidelines of the International Building Code (IBC) for existing buildings. The notched sub-purlin provides the most attachment back to the structure; and when used over an R-panel, it will increase the load-carrying capacity of the underlying purlin. In essence, by using a notched sub-purlin, structural enhancement is actually provided while the roof is being re-covered.

“We re-covered 10 to 12 hangars and assorted outbuildings with the notched sub-purlin and double-lock panel and had 100-percent success with the system. We know it will be a watertight solution long into the future,” Brown says. “Coatings are temporary fixes, and single-ply re-covers have a much shorter life expectancy than metal. Both end up being more costly, so we won’t go that route.”

#### SYMMETRY

About five years ago, Brown was introduced to a two-piece, mechanically seamed, symmetrical metal panel. “It was not hard



Figure 4 – Here, a 5-in.-tall Roof Hugger retrofit purlin and a 130-ft.-long curved symmetrical panel with 100% curved continuous clips were used to solve the problems of wind uplift and leaky transition.



Figure 5 – Finished application showing continuous panel, step-down, and welded stainless flashing.

to see it had significant advantages over the double-lock system we had been using,” he says. (See *Figures 2 and 3*.) “First, a symmetrical panel can provide better wind uplift capacity over existing frame spacing, and that is very important here in southern Louisiana. Also, the seam design on a symmetrical panel is more watertight than a double lock because there is no interruption of sealant in the seam at the clip locations. Most importantly, a symmetrical panel can be easily fixed if there is ever damage or a reason to pull a panel out of the roof at a later date. In this hurricane-prone area, the idea of being able to replace an individual panel anywhere on the roof after a storm carrying flying debris is a very big plus.”

Symmetrical standing-seam systems do not have male and female seams, but are comprised of panels with matching left and right seams. The panels are joined with a mechanically seamed cap. The panels are nondirectional, meaning they can be installed left to right, right to left, or even from the center out.

Around the same time, the Airport Authority switched insurance carriers to Factory Mutual. This required the use of FM-approved systems, along with having a professional engineer design the re-cover. The most recent re-cover with a sub-purlin installation was topped with an FM-listed 16-in. curved symmetrical panel with 100-percent continuous clips over a 5-in.-tall, notched sub-purlin system. The system met FM 1-195 approval for that construction method.

“On this job, we had a couple of challenges,” Brown says. “First was meeting the wind loads on a barrel vault with 5-ft. purlin spacing in a 110-mph wind zone. The corner pressures per ASCE-7 were -78 psf. Second was dealing with a transition between the barrel vault roof and the adjacent shed roof. This transition has been a failure since it was first installed; and over the years, several unsuccessful repair attempts had been made. By using an extra-high-notched purlin, we were able to create a 5-in. drop from the curved roof onto the transition flashing; and by using 100-percent continuous clips with the symmetrical panel, we were able to meet the FM-determined wind loading.” (See *Figures 4 and 5*.)

Responsible spenders keep an eye on their budgets, and the Lafayette Regional Airport is a responsible spender. On a recent inspection, Brown became aware of leaking issues on three rows of T-hangers.

It was a familiar problem: an exposed fastener R-panel that had endured too much Louisiana rain, heat, and sunshine.

“As we had done so many times before, we proposed installing a notched sub-purlin system to re-cover the T-hangar roofs,” Brown says. “Everyone was familiar with the system and knew it worked. We were a little surprised when we were told the budget did not allow for another notched sub-purlin re-cover.”

Discussion came back to removing the

original R-panel and replacing it in kind, but that would require the building to be cleared during the installation of another R-panel. This method would not be popular with the tenants, but it would be an affordable solution, and it could be done within the airport’s budget.

Brown recalled the new frameless re-cover system using a symmetrical standing-seam panel. Instead of using a sub-purlin or hat sections, the system uses tall clips that sit down between the ribs of the exist-

**SUSTAINABILITY STARTS AT THE TOP**

**Enviro-O-Sil**  
PROVEN LOW-VOC SILICONE ROOFING SYSTEM

**BEFORE**

**DURING**

**AFTER**

- PONDING WATER APPROVED
- LOW VOC/FLUID APPLIED
- SILICONE BASED

LEARN MORE ABOUT OUR CUTTING-EDGE ROOF RESTORATION & WATERPROOFING SYSTEMS AT [AMERICANWEATHERSTAR.COM](http://AMERICANWEATHERSTAR.COM)

**AMERICAN WEATHERSTAR**  
800.771.6643

Member of CRRC, UL, FM, and other industry organizations.



Figure 6 – Installation of the 24-gauge Galvalume symmetrical panels.

ing panel and are attached through to the purlin below. The clips hold the new panel above the ribs of the R-panel, eliminating the need for a sub-frame. Like the system used on the barrel roof, this system can be installed with 100-percent continuous clips to meet the wind uplift at 5-ft.-on-center frame spacing. The use of continuous clips offers nearly three times greater uplift resistance than standard clips. The frameless system eliminates the time and expense of installing sub-purlins and would fall within the parameters of the owners' budget.

The Lafayette Regional Airport Commission submitted the new system to FM for approval, explaining that funds were not available to install the already-approved notched sub-purlin system used on other buildings. FM approved the system for use on the T-hangars with the addition of wind clamps in the corner zones.

Each T-hangar measured 58 x 331 ft., or 19,198 sq. ft., for a total of 57,594 sq. ft. Most roofing panels measured about 30 ft. in length. Like all other re-covers at the airport, the 24-gauge Galvalume panels (Figure 4) were polyvinylidene difluoride-coated in "Regal White" to take advantage of that color's reflective qualities. Batt insulation was installed between the original roof and the new system in the fields, and a polyiso insulation was added on the perimeter. The rigid insulation provided additional support at the roof edge.

"The new system went up very fast," Brown says. "The panels were 24 in. wide, so the installer could really move. Panels run continuously from the eaves to a double row of vented ridge caps."

Crown Architectural Metal installed the roof panels on the three hangars in less than two months. Project Manager Jerry Hiltibidal estimated the project could have taken almost twice as long if they had installed sub-purlins and a new standing-seam re-cover system. To execute a complete tear-off and reroof would have been even longer and, again, an inconvenience to tenants.

"This was definitely the quicker and more economical system install," Hiltibidal says. "The continuous clips allowed us to achieve the wind uplift requirements and install the panels without sub-purlins. The clips run alongside the panels and serve as a base for the panels. They attach to the original existing purlins of the metal building."

"The other big advantage to installing this frameless symmetrical panel system is that it provided a safe platform to work on. Tearing off a roof and working on open purlins is definitely a safety challenge."

"This new frameless system made everyone happy," Brown says. "The elimination of the sub-purlins saved time and expense on installation. We kept the occupants and contents of the buildings covered with minimal disturbance, and we came in well under budget." 



Figure 7 – A 24-in.-wide frameless symmetrical re-cover system with wind clamps in corner zone per FM requirements.



Charlie Smith

Charlie Smith, national re-cover manager at McElroy Metal, founded Architectural Building Components in 1989, purchasing the equipment of a small Houston, Texas-based metal roofing manufacturer. Over the next 23 years, the company grew to be an industry-leading metal roofing and wall system solution provider specializing in metal re-covers of existing low-slope roofs. In 2012, the company became a part of McElroy Metal, enabling Smith to focus on educational and product development efforts. He recently cowrote the new RCI Metal Roofing course with Brian Gardiner. He is a member of RCI and NRCA.