

# Expansion Joint Closures in the Building Envelope:

## NO LONGER A MISSING LINK

By Douglas Pearmain

**E**xpansion joint closure systems are an integral component of a building envelope system. They absorb and survive the dynamics of the structure in numerous ways over the long term while also repelling changes in the environment from both sides. They function as air barriers, guttering or downspouts for condensation or leaks, insulation for temperature and sound, fire protection, overall weather protection, and may also be load-bearing and provide aesthetics.

Their dynamic function is not only for the building envelope, but also the internal structural system, affecting the building's overall long-term survival. Joints permit the building to expand, contract, and sway in response to forces that include thermal, wind, seismic, and other possible loads acting on structures. Joint closure systems are evolving to provide a similar level of continuity with the design and performance expectations of the envelope sealing. In some situations, expansion joint closure systems may also need to separate interior spaces for different controlled conditions and occasionally join to the exterior seals.

The prevailing construction criteria in the United States are promulgated by the International Code Council (ICC) with

many governing documents that include the International Building Code, Fire Code, Energy Conservation Code, Residential Code, Remodeling Code, and others as determined by adoption. Depending on the job location, applicable codes could be federal, state, and/or municipal, and the versions in use may vary and have amendments from 2000 forward.

In addition, local authorities having jurisdiction (AHJ) may have special criteria that require deviance from the model code.

Many codes reference supplemental standards that must be understood in order to fully comply. Keeping up with the statutes, material changes, techniques, and other areas is critical in building a structure that will perform systemically for many years.

### PROCESS

The time to start thinking about and addressing expansion joint closure systems is as soon as it is anticipated or understood that a need exists. It may seem easier to leave these details until later in the process, but typically, it is not. Waiting to address expansion joint closure systems may create

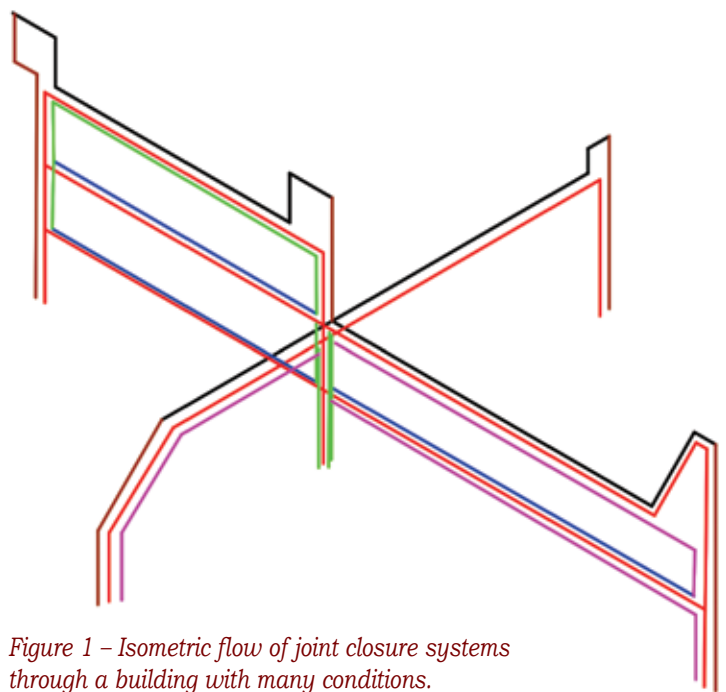

Figure 1 – Isometric flow of joint closure systems through a building with many conditions.

Joint number/ Grid Location (Wall or Roof)	Nominal/ Designed Joint Size (UoM)	Open* (UoM) Movement @ Mean Temp.	Closed** (UoM) Movement	Shear** +/- (UoM)	Vertical** (UoM)	Filler: Fire Barrier, Insulation, Vapor Barrier, Gutter	Other Type of Closure Info
E/5 W	100	25	25	50	45	FB	Roofing EPDM
C/3 W	150	50	50	x	35	Ins	Metal
2/G 3-9 R	100	50	50	35	x	FBG	Mixed
1/N 5-11 R	125	75	75	25	x	FB	Mfg. Bellows

Ins = Insulated, FB = Fire Barrier, FBG = Fire Barrier Gutter, UoM = Unit of Measure

\* Joint size at a nominal temperature. When verifying a joint condition or size, consider that colder-than-normal/nominal conditions will make the joint larger and warmer will make the joint smaller, and adjust accordingly.

\*\* Maximum movements expected based on code requirements, construction, and all related factors under severe conditions of temperature, winds, and seismicity.

*Table 1 – A table such as this might appear in plans to clarify the entire joint listing and closure systems requirements. It may also correspond with an isometric “flow” diagram.*

very challenging alterations to design details and/or existing construction in order to accommodate a proper closure.

Expansion joint openings, size, location, and overall performance need to meet specific movement criteria in order for the structure to perform well. Keeping the elements out or isolated within a building is becoming more complex. Requirements for expansion joints and their closure systems are also changing with codes, LEED® designations, and overall designs.

Envelopes today consist of many products that must meet a variety of criteria to construct, remodel, or rehabilitate a building. Structural movements and loadings are determined by design professionals (structural engineers) based on the building’s location and exposures, soils, shape/configuration, type, occupancy, and the materials used. Proper closure selection requires full understanding of all the criteria and elements in play.

Manufacturers of expansion joint closure systems are both responding to the needs and anticipating others, resulting in many new products and solutions. They are an excellent source of information and solutions, and it should be a priority to get them involved early and keep them in the process. Project details of abutting expansion joints need constant checking to assure that an entire linked closure system will work together through all the twists, turns, substrates, materials, and orientation changes and clearances for successful installations.

One of the best ways to do this is to simultaneously create a simple stick



*Figure 2 – Field condition of a seven-way primary transition with combined changes.*

isometric flow diagram and view all joint conditions and systems in a perspective configuration, along with a table of the joint locations, size, materials, and orientations. See *Figure 1* and *Table 1*.

*Figure 2* is similar to the five-way intersection at the center of the detail in *Figure 1*. It simply shows the importance of understanding the building conditions. The two little vertical flexible rises were omitted on either side of the curbs joining the lower roof-to-wall bellows to the upper and larger curb-to-curb bellows. Also, the curb condition bellows just ended at the metal wall joint cover (note all the patching). In spite of many products’ capabilities to correct or compensate for existing conditions, they must be specified, detailed, and installed to attain an integrally functional building envelope closure system. Keep in mind that this illustrates only the primary (exposed) closure system. The job requirements may call for additional materials to be installed

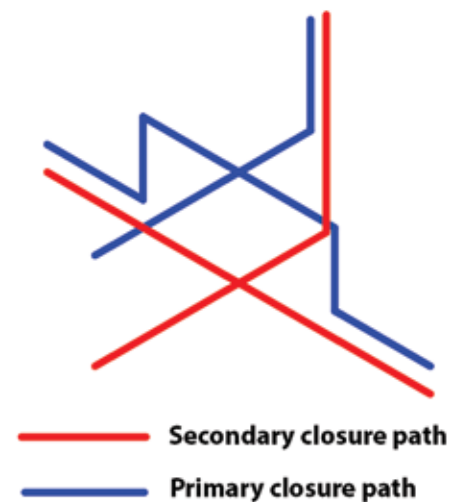

*Figure 3 – Blue lines show the primary closure path. Red lines show the secondary closure path for Figure 1.*

beneath it. These other materials must have the same or greater movement capabilities in order to survive all of the building’s movements.

In *Figure 3*, blue lines indicate the path required for a primary cover, regardless of product choice. Red lines indicate the path required for a secondary closure. Note that there are not as many vertical changes along the secondary path. This is because the secondary closure may serve as a gutter, and it can traverse conditions that the primary may need to go around or over. Mounting points may change above, while secondary may follow a straighter line.

*Figure 4* shows a bellows closure solution for the conditions in *Figure 2*. It also represents the path required unless there were other changes made to the construction details.

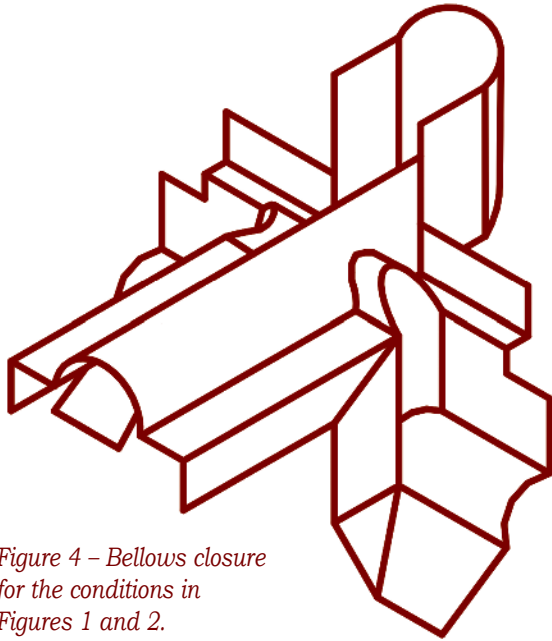

Figure 4 – Bellows closure for the conditions in Figures 1 and 2.

As the design progresses, more detailed information in 3-D (BIM), isometric, or axonometric can be provided. This will greatly assist and serve to ensure a continuity of joint closure materials in all planes by all trades. The larger and more complex a project is, the greater the importance of this task becomes. Depending on the job location and size, the entire closure system could be installed by many contractors. In some locations and under different conditions, the work could be done by fewer subcontractors or even just one specialty contractor throughout the building.

Communication, coordination, and

sequencing are critical under all circumstances for proper function. Components, placed end-to-end or lapped for closure and with adjacent substrates, are necessary to ensure envelope performance. The goal is to achieve similar results within the expansion joint closure systems as with the rest of the building envelope with respect to overall performance.

Lack of proper attachment and sealing of components reduces continuity and can lead to condensation, energy loss, unnecessary noise, and other undesirable conditions that are usually very expensive to remediate.

Because an expansion joint and its closure system complement the entire structure, understanding just how each area impacts the next is not optional. It should not become a “worker figure out” or “make-do” situation. This generally leads to costly backtracking if realized during construction, or even bigger problems later.

#### PRODUCTS

It is best to check with manufacturers for the most appropriate choices to suit the conditions of the job. For shop-made details such as those provided by the Sheet Metal Air Conditioning National Association (SMACNA), the National Roofing

Contractors Association (NRCA), and the Copper Development Association (CDA), check each association’s latest manuals and websites, as some criteria may have changed for fabrication clearances.

Just as with any other building envelope materials, the functionalities of the expansion joint closure systems are subject to installation variations. Because of the range of conditions expansion joints may encounter in any run, it is suggested that systems be installed by individuals trained specifically for the tasks.

There are many different closure system configurations to choose from for both horizontal and vertical applications when designing the project. Some of the horizontal or sloped systems are shown in Figure 5.

These represent a range of “roof” styles; however, there are many more to consider. Note the variations in mounting considerations. Systems may consist of a primary weather-resistant or weather-tight visible cover element with a secondary or backup system as either an integral or optional item. Mating some profiles to others simply will not work on the exposed or primary closure or even secondary level.

Vertical product selections can also consist of two layers and have even more choices where aesthetics are a major consideration. A few are shown in Figures 6, 7 (the latter is shown for a roof but can be altered for vertical use), and 8. Contact the respective companies for properties and capabilities.

## Publish in *Interface*

*Interface* journal is seeking submissions for the following issues. Optimum article size is 2,000 to 3,000 words, containing five to ten graphics. Articles may serve commercial interests but should not promote specific products. Articles on subjects that do not fit any given theme may be submitted at any time.



ISSUE	SUBJECT	SUBMISSION DEADLINE
April/May 2015	Convention review	January 15, 2015
June 2015	Energy	February 13, 2015
July 2015	Steep roofs	March 13, 2015
August 2015	Windows and skylights	April 15, 2015
September 2015	Business issues	May 15, 2015
October 2015	Technology	June 15, 2015

Submit articles or questions to Executive Editor Kristen Ammerman at 800-828-1902 or [kammerman@rci-online.org](mailto:kammerman@rci-online.org).

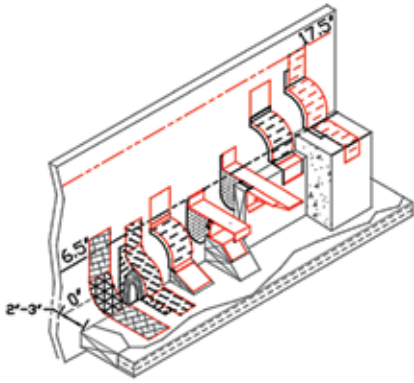

Figure 5 – Roof-to-wall joint closure styles.

Primary and secondary joint systems must be compatible within a given continuous run and the surrounding substrates.

Note that should a substitution request be submitted for any of the conditions on the job, the originator of the request should be prepared to show that the substitution can meet all the details and tests. This includes transitioning to other specified

products beyond the scope of the request if others are involved. For example: A contractor for an area may only submit the most basic form of a substitution request for expansion joint closure systems that directly contact its materials. The contractor might choose to ignore the intersections, clearances, and ultimate connections with expansion joint systems from above, below, or by “T-ing” into the requested substitution materials. Movement requirements must also be verified.

With code requirements today, most buildings will require some secondary configuration closure unless a monolithic, multipurpose closure (such as compressible foam filler or webbed/honeycomb) is used. Consider that any additional closure system behind the exterior one may also be a primary system such as an air barrier or mois-

ture containment. It must be better than the “primary” exterior one. In some cases, joints will have closures that protect for both inside and outside.

Regardless of the system(s) chosen and the reasons for their choice, there is now the ever-present compatibility consideration of making the entire system work as one in all cases.

### MOVEMENTS

The most common movements the construction industry is familiar with are the



Figure 6 – EMSEAL compressive.  
Photo courtesy of EMSEAL.

Figure 7 – Johns Manville insulated for roofs; can also do verticals with changes.  
Detail courtesy of Johns Manville.



Figure 8 – Watson Bowman extruded.  
Photo courtesy of Watson Bowman.



daily and seasonal ones resulting from temperature, winds, and manmade movement, such as traffic loadings. Seismic forces are a factor that can produce much greater forces and movements than the other causes but at lesser frequency. The areas affected by the potential of a seismic event are limited; however, the United States Geological Survey (USGS) continues to find additional areas and increases the affected areas. In many cases, this results in code changes and the way buildings are built and their resulting joint opening size requirements

Expansion joint closure system movements that the building/design and construction industry is familiar with are: in/out (tension/compression), up/down, back/forth (shear), and combinations of these. See Figure 9.

### Movement Terms

A factor in anticipating movements is that in different areas of the country and among different manufacturers, movement is discussed in different ways.

A basic example that references a 50% movement expected in/out on a 6-in. joint opening such as that shown in Figure 10 can result in the following.

1. Upper half of Figure 10. One interpretation is that the joint will move a total of 50% of the nominal design joint opening size, meaning  $\pm 3$  in., for a total of 6 in. (from 3 to 9 in.).
2. Lower half of Figure 10. Another interpretation is that it will move a total of 50% of the joint opening, which would amount to 50% of the joint size (3 in. total), or  $\pm 1\frac{1}{2}$  in. of a nominal 6 in., meaning from  $4\frac{1}{2}$  to  $7\frac{1}{2}$  in.

Another way to indicate this would be to say that the joint moves  $\pm 25\%$  from nominal 6-in. design size.

NOTE: Up/down and back/forth (shear) are not discussed at this time, but adding

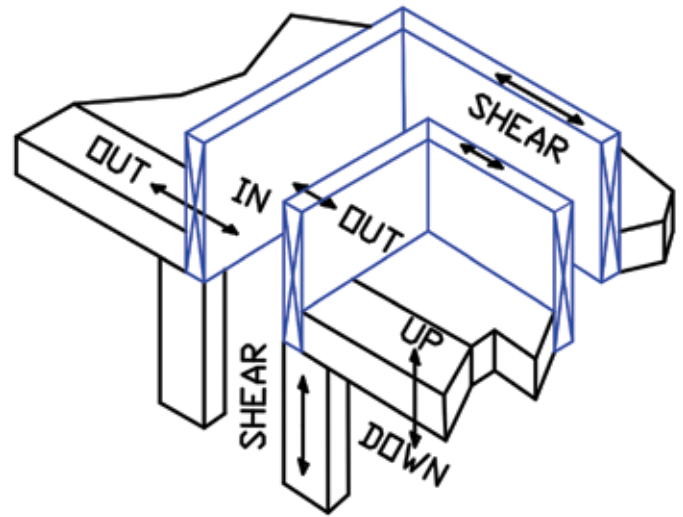

Figure 9 – Expansion joint closure system movements.

in these two other movements can complicate the design and may change mounting conditions, size, or the product and configurations needed. Secondary closures must be designed to accommodate maximum movements in all directions as their minimum size for redundancy and safety.

When a joint requires a filler for fire, thermal, or sound performance, that product will take up space that may need to be accounted for in the movement calculations. Many of the fillers are “friable,” and if compressed or rubbed beyond a certain point, damage may occur, and their performance may suffer over the anticipated lifecycle. Should the fillers get wet, there is also a potential for premature degradation of function.

The difference can be significant, and depending on the product chosen to close the opening, it can mean the difference between function and dysfunction.

Complete and accurate communication of all related joint conditions is needed by the suppliers of the systems for accurate assessment of the correct product type, style, and size. These include what the expected/calculated/known movements are and other performance criteria. The manufacturer(s) then can recommend the proper products and sizes.

### OTHER CRITERIA

The following four items are all criteria that are included in building codes. The performance of the building envelope will reflect one or more of these and can affect expansion joint closures, so expect to see them referenced more frequently.

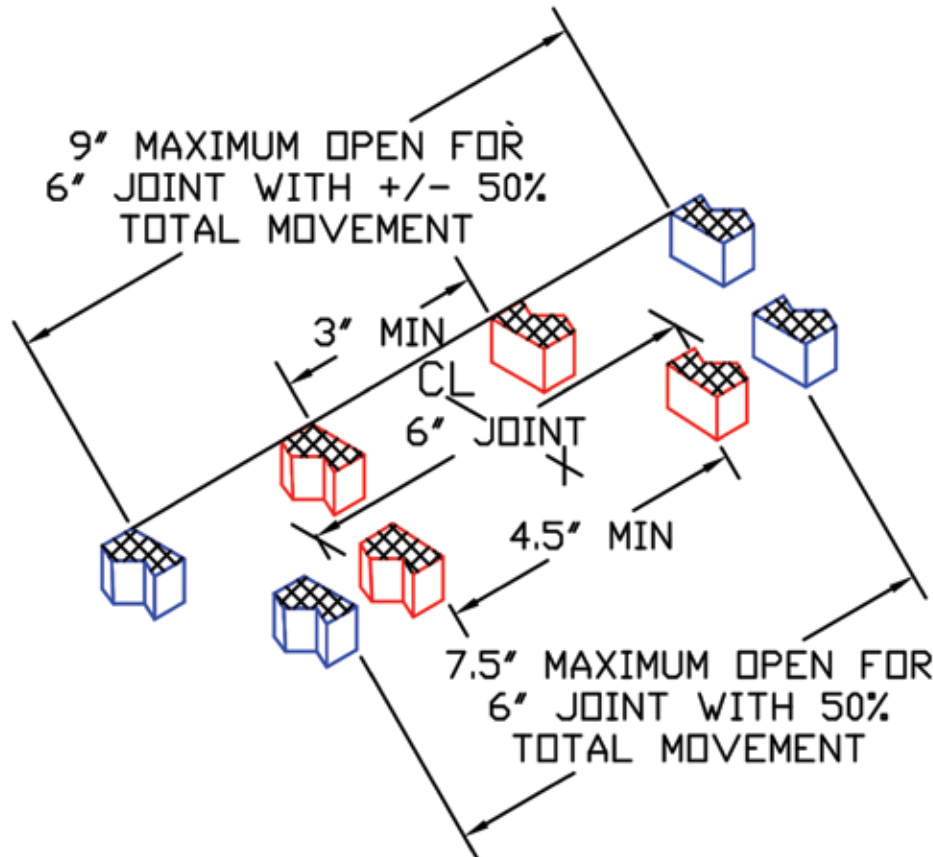

Figure 10 – Detail of a joint with two different movement references.

## Air Barriers

Materials undergo testing according to ASTM E2178-13<sup>1</sup> to prove that they do, in fact, serve as an air barrier. Expansion joints are part of the envelope, and a number of them have been tested to this standard and passed. Check with the manufacturer and Air Barrier Association of America (ABAA) for the latest information.

Collectively, the systems work together, so the standard may refer to the primary closure or require a secondary closure element that will need to be continuous.

## Fire Ratings

Fire-rated structures will require joint closures with ratings from one to four hours, matching adjacent construction. Rated systems need to have matching closure-rated system assemblies, too. Always consult a product's fire-rated listing criteria prior to installation. It will delineate fasteners, locations, caulks, sealants, transitions, splicing, substrates, and required/permitted cover materials. For instance, fire-treated lumber may not be an accepted substrate for mounting even a one-hour assembly when it should be concrete.

A standard testing for fire-rated systems is UL 2079.<sup>2</sup> Look for it in product literature.

What makes these conditions so challenging is that the intersections can become very complicated and interesting to detail and install. Also envision a condition that may not only involve several fire-rated external joints, but also have to tie into an internal floor joint from behind, as in *Figure 1*.

Construction of additions to buildings that already have existing fire-rated expansion joint closure systems adds an additional level of challenge to the matrix of materials. Should the changes require a continuation of a fire-rated system, one of three things needs to happen:

1. The new system must be the same as the existing in that it will have the same physical properties and movement capabilities so that the two will splice well together.
2. The new system can be different than the existing if a suitable alternative design configuration can be worked out and the two do not have to contact each other. Exercise caution when determining this configuration to ensure it still meets the codes.
3. Should the old system no longer be available and the new system have

to tie into the existing, it is quite possible that the old materials will need to be removed and replaced with new ones.

Note that fire-rated systems are not mix-and-match—even from the same manufacturer, let alone across multiple manufacturers' product lines. They all stand alone because of different materials, configurations, splicing, and movements.

## Thermal Insulation

Consider that many expansion joint closures involve minimal to no specific insulation qualities, such as single-layer or dual-layer with an air gap. Some other products that are monolithic, such as compressible foam, may have multiple values associated with them, such as an R-value or thermal-resistance rating.

While expansion joints and their closures are a very small part of the building envelope, they can be a significant chal-



**Flex**  
The Expert Source for  
Single Ply & Multi-Ply  
Roofing Solutions

Chicago's Jardine  
Water Filtration Plant  
450,000 sq ft of Flex  
Elvaloy® KEE Fleece  
Back Roofing System

## Flex is the Building Owner's Choice for Long-Term Roofing Solutions

Building professionals trust Flex for all their roofing needs from the deck up, including all roof edge products. Flex Roofing Systems are covered by our Total Roof System Long-Term Warranties. We eliminate the hassle, make sure every detail is considered, and ensure long-term durability. Flex materials are the highest performance thermoplastic single ply roof solutions in the industry. Our expert in-house technical department assures quality installation on every job.

### COMMERCIAL



### INSTITUTIONAL



### RESIDENTIAL



### GREEN



TOP QUALITY PRODUCTS • PERSONALIZED SERVICE • OUTSTANDING ROOF PERFORMANCE

### Flex Elvaloy® KEE • Flex PVC • Flex TPO

Flex partners with roofing consultants and contractors in every state to design and install systems that preserve energy, save the environment and last for decades.

See us at IRE Feb 24-26, 2015 • Booth #1737  
See us at RCI March 7-8, 2015 • Booth #236



25 Years strong and thousands  
of projects completed.

**Flex**

Leader in Thermoplastic  
Single Ply Roof Systems

1-800-969-0108  
FlexRoofingSystems.com



lenge. Should a particular cold spot develop condensation, this can lead to mold or rot over time.

Uninsulated and improperly installed expansion joint systems can cause the same effects as leaving a door or a window open.

### Sound Insulation

Some buildings—such as housing units, office buildings, performance halls, and theaters—have a sound-deadening requirement for the envelope. This will be for any number of considerations, such as an adjacent high-traffic area, industrial complex, airplane or train traffic, crowds, or other factors.

Expansion joint openings are also a potential “noise hot spot” if not properly addressed with appropriate resilient fillers or an encapsulated/sleeved material and flexible or sliding materials to deaden the sounds as much as possible.

It may not be possible to attain the same sound transmission class (STC) ASTM E90-09<sup>3</sup> reduction as the rest of the building envelope, but every attempt should be made.

### CONCLUSION

Lapses in building envelope construction are no longer acceptable. Expansion joint closure systems are now under the

same scrutiny as the rest of envelope. Due to the dynamic nature of their purpose, they may not always be able to attain the exact same results; however, it is possible to approach the overall design criteria with proper and timely communication, planning, detailing, and installation.

Expansion joint closure systems are not only barriers against air, weather, temperature, noise, and fire but also must provide this security while constantly moving with the building. They potentially make more abutment material transitions and bridge between different substrates with more trades doing the installation than any other product on the job. This is where a full building flow diagram and 3-D details convey information to all.

As always, the system is only as good as its weakest link. 

### REFERENCES

1. ASTM E2178-13, *Standard Test Method for Air Permeance of Building Materials*. <http://www.astm.org/Standards/E2178.htm>
2. UL 2079, *Standard for Tests for Fire Resistance of Building Joint Systems*: <http://ulstandardsinfonet.ul.com/scopes/scopes.asp?fn=2079.html>
3. ASTM E90-09, *Standard Test*

*Method for Laboratory Measurement of Airborne Sound Transmission Loss of Building Partitions and Elements*, ASTM International, West Conshohocken, PA, 2009, [www.astm.org](http://www.astm.org/Standards/E90.htm), <http://www.astm.org/Standards/E90.htm>



Douglas Pearmain,  
CDT

*Douglas Pearmain, CDT, has 32 years of commercial construction and roofing experience, representing three large manufacturers. Currently a manufacturer's rep for D2Marketing in Indianapolis, he has assisted on ANSI/SPRI ES-1*

*and GD-1 Standards committees and published four articles on expansion joints. He has also been the metal systems and single-ply engineer for a roofing manufacturer, conducting tests at UL, FM, Intertek, and others. Pearmain has four expansion joint patents and has made presentations at various industry events. He is currently programs chairperson for the Indianapolis chapter of CSI.*

## ARMA and ASTM Develop Asphalt Roofing PCR

The Asphalt Roofing Manufacturers Association (ARMA) has partnered with ASTM International to develop Product Category Rules (PCR) for asphalt roofing in North America. The new PCR will provide consistent methodologies for asphalt roofing manufacturers to measure and report the expected environmental impact of their products. This new document can be accessed free of charge on ASTM International's website ([www.astm.org/certification](http://www.astm.org/certification)).

PCRs provide guidelines for the development of Environmental Product Declarations (EPDs) for a specific product group. PCRs are valuable to any industry because they streamline the process through which products are measured and their environmental impacts communicated, creating globally consistent documentation. Asphalt roofing manufacturers can use these guidelines to review their own products and develop an EPD, which is a verified document that reports the expected environmental performance of a product based on its expected life cycle. An EPD uses the data collected through PCR guidelines to provide comparable environmental impact data for similar products.

ARMA and several of its member companies participated in the development of this PCR, titled “Asphalt Shingles, Built-Up Asphalt Membrane Roofing, and Modified Bituminous Membrane Roofing.” The guidelines cover asphalt shingles applied over underlayment and low-slope roofing assemblies consisting of various combinations of factory-produced asphalt-saturated or coated base sheets, ply sheets, and cap sheets, together with specified viscous asphalt coatings, adhesives, and surfacings.

ASTM began its PCR and EPD program in 2012 to provide an infrastructure that can be used for the evaluation and communication of a product's full-life-cycle environmental impacts. ASTM develops PCRs in partnership with various segments of the building construction industry and in accordance with international standards.