



EFFECTIVE STRATEGIES TO RESTORE AND UPGRADE HISTORICAL STEEL WINDOWS

BY ARTHUR FEMENELLA SR.

INTRODUCTION

The fenestration of a historical building is a focal point and often the defining feature of the building's style and period. Unlike wood windows in historical buildings, steel windows are often looked upon as replaceable and not worth the effort of conservation. This is especially true of the mass-produced rolled steel windows manufactured from the end of the 19th century through the mid-20th century that can be found in commercial, residential, and institutional buildings throughout the United States.

There are a number of reasons why steel windows are often slated for the scrap heap, but high on the list is the presumption that they cannot be made more energy-efficient. The fact that there are myriad replacement options in the market often influences the decision, as well. But the sight lines, proportions of elements, profiles, and shadow lines of many of the modern replacements do not match the original details of the windows they are intended to replace. If the windows are indeed defining elements of the historical architecture, the substitution of replacement windows can result in the loss of the original character of the building.

Beyond the aesthetic benefits of restoring steel windows, the repair and/or retrofit of existing steel windows is often more economical than the complete replacement option. Further, many of the old alloys appear to demonstrate greater resistance to corrosion than some of the modern alloys used to fabricate new steel windows.

The above notwithstanding, there are situations where window replacement makes sense. This can be in buildings where the original windows are not defining design elements and good replacements with higher energy efficiencies are available, or when the windows have deteriorated to the point at which restoration would not be economically feasible.

The purpose of this article is to assist building owners and committed preservation professionals to determine the following:

- How to assess the importance of the windows to maintain the character of the building
- When restoration of steel windows is appropriate
- What to know before the project starts
- What methods and materials produce good results
- How steel windows can be made more energy-efficient

BRIEF HISTORY

The first metal windows were fabricated from wrought iron by medieval blacksmiths in England and other European countries. Large pieces of glass were nonexistent at the time, and glass in general was a precious commodity; so, these metal windows were typically glazed with leaded glass panels—small glass diamonds or squares (quarries) held together with lead cames. Most of these windows were fixed units, but blacksmiths with greater skills could produce operable sections in the window, typically casements or center-pivoted sash.

In the mid-17th century, changes in architectural design featuring Palladian fenestration favored windows made from wood with complex moldings and varying profiles. In the mid-18th century, advances in metal casting allowed for more complex metal windows to be fabricated in the factory from cast iron. Detailing only previously seen in wood windows could be carved into the wood positive that would be used to make the mold for the cast iron. This enabled the window manufacturer to offer details and profiles such as glazing T-bars with rounded edges, and ovolo- and other complex-shaped perimeter moldings only seen before in wood sash.

Cast-iron windows became quite popular throughout England. They were used

in housing and institutional buildings and were quite the thing for workhouses and asylums. An 1848 patent included the phrase, “[C]ast-iron sash windows appear to possess advantages for lunatic asylums, workhouses, and schools, since when open, the sash bars [prevent] patients escaping or children falling.” Imagine including that line in today's window advertisements. In the 19th century, cast-iron windows could be seen in cities throughout America and in impressive public buildings such as the 1863 iteration of the cast-iron dome on the U.S. Capitol.

In 1856 England, Sir Henry Bessemer developed a process to produce hot-rolled steel on a high-production basis. Although a method for making rolled steel had been known in Asia as early as the 11th century, the earlier process was a very time-consuming affair. The Bessemer process was so effective that it became a major driver of the Industrial Revolution, coming to the United States soon after its inception.

It was not often used for windows in the U.S., however, until the 1890s, when continuing technical refinements brought the process to the point that allowed for the mass production of steel windows. The demand for steel windows was further enhanced after numerous deadly fires

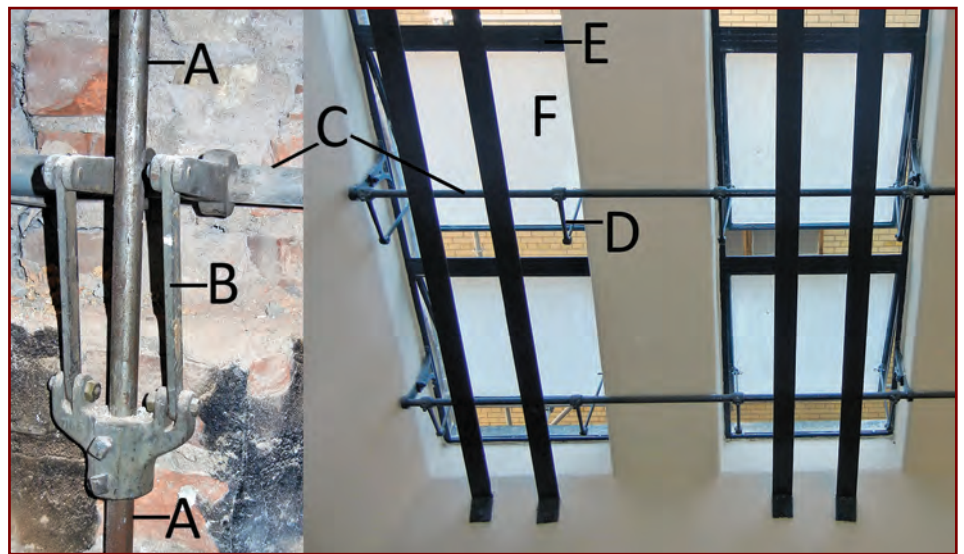

Figure 1 – Typical continuous window at Yale University's Payne Whitney Gym. The mechanism at the left is buried within a cavity in the exterior wall. Section "A" is a continuous vertical rod that is connected to all of the horizontal rods ("C") in the window. The bottom of "A" is connected to a screw mechanism that rises or falls as the operator turns a geared crank that is accessible from the interior of the building. As the crank is turned, the screw mechanism rises, causing "A" to rise. As "A" rises, the hinged lever arms at "B" transfer the upward displacement into rotational movement of "C". As "C" passes through the wall, it is connected to lever arms "D" that transfer the rotational movement of "C" into horizontal displacement of "F," the opening sash. "E" indicates the hinge location of the sash.

occurred in major U.S. cities, resulting in far-reaching and strict fire codes. Steel's exceptional strength allowed architects to design great walls of windows, adding architectural interest to the exterior while flooding the interior with light, not unlike the introduction of the flying buttress, which had allowed medieval masters to greatly enlarge the stained-glass windows of ancient cathedrals.

At first, steel windows mimicked those of wood design, including double-hung and casement windows. Additional designs, enabled by steel's strength and thin profile sections, came onto the market. These included center pivot, hopper, or projecting windows, as well as austral windows, in which an upper section projects out while the lower section projects into the building. In factories and large institutional buildings, long banks of projecting windows were tied together with common, crank-type operating systems, often referred to as

continuous windows. This would allow the ventilation of large spaces quite easily.

At the continuous window installation seen in *Figure 1* at the Payne Whitney Gym at Yale University, one operator can open 45 sashes at one time by operating one geared crank. These systems often fall into disrepair due to lack of maintenance. Any corrosion that develops in the lever arm connections restricts operability. With a good understanding of the system, however, they can be successfully returned to full and easy operation.

TO RESTORE OR REPLACE

The first order of business is to determine if the windows should be restored or replaced. Engage with a preservation professional who is knowledgeable about the style and period of construction of your building. Determine if the steel windows are a defining design element such that their loss would denigrate the architectural esthetic

of the building or confuse the viewer as to its original design intent. Major differences between historical steel windows and new aluminum replacements include the scale and dimension of the individual window members (i.e., stiles, muntins, mullions, shadow lines). Even if the primary use of the building changes (such as manufacturing facility to residential), if the windows are central to the historical character and feel of the building, they should be retained and restored.

Surface rust always looks worse than it is; oxidized steel occupies seven times the thickness of new steel. Unless severe corrosion has resulted in extreme loss of material and/or

complete loss of frame and sash members, or rust jacking of the subframe has dramatically displaced the window, restoration can often be quite successful and economical.

DEVELOP SCOPE AND MAGNITUDE

The next step in the process is to assess the condition of the windows. This will determine if the overall project is feasible and if the windows can be restored in situ or if they must be removed to the shop. Develop a logical and comprehensive numbering system for the windows to be addressed on a floor plan or elevation drawings, to include identifiers for the disparate parts that may have to be disassembled. Complete an initial window survey and develop a window schedule with attendant photographs that indicate the types and extent of problems found on a window-by-window basis. Moisture/standing water resulting in corrosion is the prime enemy of steel windows. This effect is exacerbated if the windows are not properly maintained or if the moisture is trapped at certain areas of the windows.

The level of corrosion is the primary factor that will determine if the work can be completed in situ. On most projects, there is a mix of minor, moderate, and severe corrosion. The extent of the corrosion is often determined by the elevation at which the window is found, the design of the window, and what section of the window is subject to standing water. Corrosion may be categorized thus:

- **Minor corrosion:** primarily on the surface of the metal
- **Moderate corrosion:** reaches deeper into the metal, resulting in a rough, bubbling surface but no rust jacking. (This is the displacement of steel window members due to the expansive force of rusting—the formation of iron oxide.)
- **Severe corrosion:** Rust has eaten deeply into the metal, resulting in structural damage and/or rust-jacking of the members.

During inspection, determine if the design or installation of surrounding building elements is allowing the infiltration of damaging water. Assess the original design details to determine if water shedding is encouraged throughout the system. Check to see if the metal sections are bowing or are twisted and inhibiting operation of the window. Inspect the condition of hardware, such as latches, hinges, hold-opens, fasten-



Figure 2 – William J. Nealon Federal Courthouse in Scranton, Pennsylvania.

ers, and the window glass and glazing (putty or sealant).

The next step is to dismantle a window to reveal how it is put together and installed. Myriad profiles, styles, and methods of installing steel windows have been employed. Due to the great strength of steel, the windows were often installed into the building as it was being built, rather than into a framed-out rough opening later in the building process. The subframes of these built-in windows are so integrated into the building fabric that too much damage and added cost may result when trying to completely remove them. In this case, it may be possible to restore the sash and frames off-site, but the primary subframe must be addressed in the field. This was the condition at the Nealon Courthouse project.

The 284 steel windows of the Nealon Courthouse in Scranton, Pennsylvania (Figure 2), were restored by Femenella & Associates, Inc. working in concert with C&D Waterproofing. The project included 34 monumental windows that span the third and fourth floors and include cast-iron ornament and marble spandrel panels.

Numerous upgrades were made to the windows during the project to increase energy efficiency and ensure proper water drainage and resistance to corrosion (Figure 3).

REMOVAL PROCESS

As part of the Nealon project, drawings were developed indicating which sections of the window were removable and which sections would have to be addressed in situ (see Figure 4). These drawings are for the monumental upper windows with cast iron ornament and marble spandrel panels.

The operable and fixed sashes were removed first. This allowed access to hidden fasteners that were securing the frames. Due to inaccessibility or severe corrosion, many of the fasteners had to be cut out. All fasteners used during the reassembly were stainless steel.

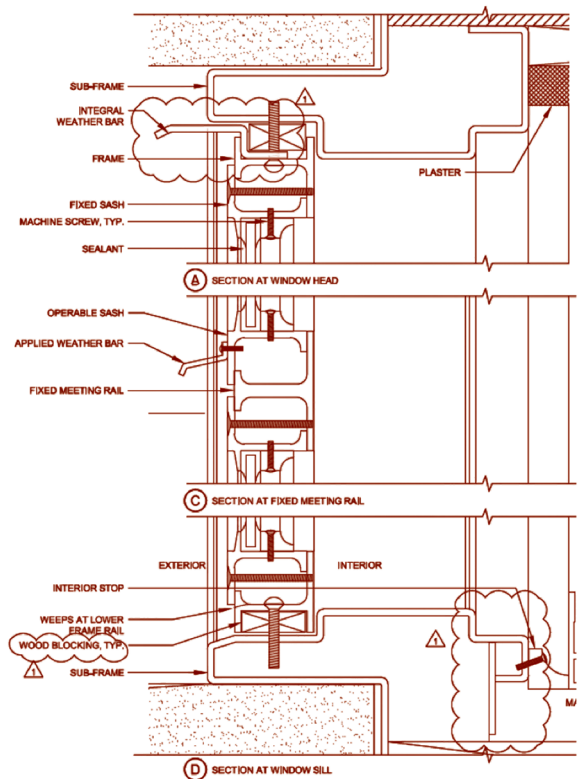

Figure 3 – Typical window details prepared for the Nealon Courthouse.



PREPARE FOR STORM SEASON WITH OUR LIGHTNING PROTECTION SYSTEM

- UL Listed
- INTEGRATED - Fits over our Existing Systems
- Allows access to the entire roof structure
- Cost Efficient





PRR
PREMIER RAIL SYSTEMS

WWW.LEADINGEDGESAFETY.NET

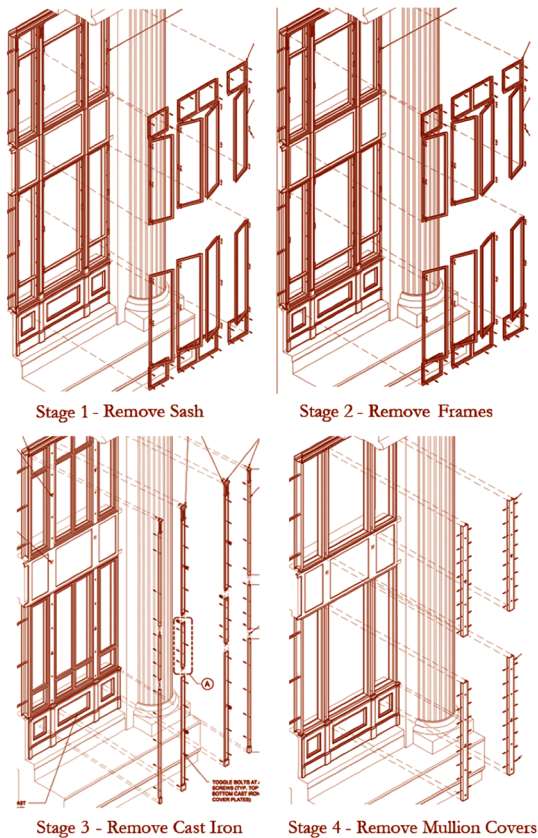

Figure 4 - Removal sequence drawings.

The cast-iron columns, capitals, and pedestals were removed; they were attached with plain steel toggle bolts through holes in the mullion covers. The mullion covers were removed next; they are structural in design and function. The larger cast-iron base spandrel and base moldings were restored in situ; they were attached from the interior and would have required substantial demolition in order to obtain access to the fasteners. The stone spandrels found between the upper and lower sash were removed.

In the original survey, many of the stone panels were slated for replacement due to surface deterioration. C&D Waterproofing, the general contractor and masonry contractor for the project, proposed polishing the back sides of the stones and installing them with the newly polished side facing out. This approach saved a great deal of original historical fabric and is emblematic of the constant analysis and scope adjustment that is

critical to the success of large steel window restoration projects.

RESTORATION PROCESS

Once the window has been dismantled, it is time to address the problems. On most projects, conditions vary from elevation to elevation and even between similar windows on the same elevation. As mentioned before, water is the enemy, and wherever water is allowed to collect or breaches the paint film, corrosion will occur. Take special note of areas where water collects, and ensure that design changes are made during the restoration to facilitate the rapid shedding of water in these areas. The following will discuss specific steps for the restoration process.

MINOR CORROSION

If the windows exhibit minor corrosion (see Figure 5), no rust jacking, and the paint is in fairly good condition, repairs can typically be completed in situ. For remediating minor corrosion and damage, complete the following:

1. Establish if lead paint or other hazardous materials will be disturbed during the repair process, and take appropriate steps to isolate the work area. Ensure that the owner and all workers are aware of the possible hazard. Lead paint can only be removed by contractors who are certified under the Environmental Protection Agency's (EPA's) Lead-Safe Certification Program.
2. Remove loose and flaking paint and all corrosion. This can be accomplished with hand tools. With proper protection of surrounding materials, power tools with wire wheels may be employed. For more experienced craftsmen, a pneumatic needle scaler may be used. Removal of paint with chemical strippers can also be appropriate. Ensure all surfaces are neutralized prior to application of paint. Clean all bare metal surfaces with a solvent such as denatured alcohol, or follow paint manufacturers' instructions. Prime with a rust-inhibiting primer immediately after cleaning to prevent continued corrosion.
3. Inspect all hinges, fasteners, hold-opens, latches, and other hardware. Replace all missing elements. Lubricate and repair all hardware

LOOKING FOR A FEW GOOD PICTURES

Like to see a picture of your company's project gracing the cover of *Interface*? Give your company industry-wide exposure!

We are looking for attractive, four-color, high-resolution, vertically oriented shots to illustrate our monthly themes.

Submit original photograph or digital file (300 dpi, 8.5 x 11 in.) to:

Kristen Ammerman, RCI, 1500 Sunday Drive, Suite 204, Raleigh, NC 27607
E-mail: kammerman@rci-online.org • Phone: 800-828-1902



that does not operate properly. Missing elements are often available from online restoration hardware supply houses.

4. Often, operating hardware is bronze or architectural brass. Remove from the window, strip paint off, and polish before re-installing.
5. Replace all broken or missing glass, and inspect setting compounds. Be cognizant of the character of the glass in the window. Window glass made before WWII tends to have some distortion due to the older manufacturing process. This can be a distinctive feature of the windows and should be maintained. Replacement glass can be salvaged from old windows. We have used Restoration Glass® provided by S. A. Bendheim of Passaic, NJ. If the setting compound needs to be replaced, consider using a setting tape/tooled caulk system rather than the old hard-setting putty.
6. Finish-paint the complete window, frame, and subframe.
7. Investigate possible thermal upgrades through the addition of weather-stripping. The use of adhesive-backed foam tapes is not recommended; they typically fail after a short duty life. On many steel windows, there may not be sufficient clearance to install metal or plastic weather-stripping. A



Figure 5 – Example of minor corrosion of the steel sash.

custom gasket can be made in situ, employing a bond-break tape and silicone caulk. Apply the bond-break tape to the surface of the operable sash that closes against the frame rebate. Apply a small bead of caulk to the rebate and close the window. It works best if the sash can be secured in a position just short of full closure. Allow the silicone to cure, open the sash, and remove the bond-break tape. The silicone will slightly compress when the sash is closed.

8. Remove and replace sealant at the intersection of the subframe and surrounding building materials,



Figure 6 – Example of moderate corrosion of the steel sash.



Turn roof tops into beautiful deck areas

The PAVE-EL® Pedestal System

- Transforms flat roofs into attractive, maintenance-free, paver stone terraces.
- Elevates paver stones for perfect drainage.
- Levels paver stones and ensures their uniform spacing for an ideal roof terrace surface.
- A perfect solution for laying mechanical walkways for use by maintenance personnel.
- Ideal for laying paver walkways in roof gardens.



PAVE-EL®
ENVIROSPEC INCORPORATED

716-689-8548 • www.envirospecinc.com



Figure 7 – Example of severe corrosion of the steel sash.

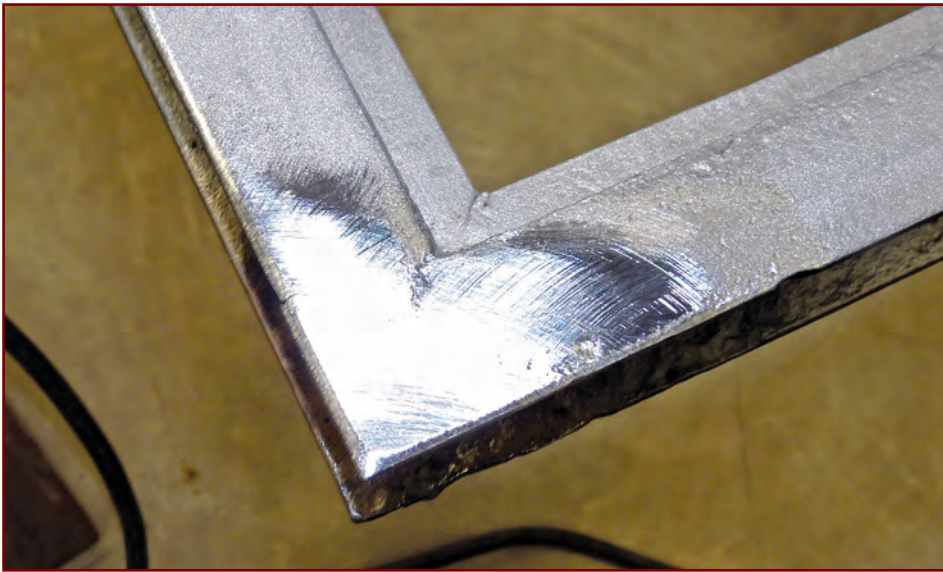

Figure 8 – Repair of severe corrosion. After removal of corroded material, an oversized new steel piece is welded in place. Repair patch is then ground down to match original profile.

employing appropriate primers, backer rod, and bond-breaking tape.

9. Check surrounding building fabric to ensure that water is being directed away from the windows and the building.

MODERATE CORROSION

For windows with moderate corrosion (see Figure 6), the above steps are followed as well. In addition, minor straightening of the sash or frame may be required.

1. To straighten the sash in situ, remove the glass and glazing. Using a wood or metal member to distribute the load, use clamps or an improvised come-along to exert pressure on the affected window member. Often, due to “metal memory,” the section has to be forced slightly beyond the ultimate desired plane to create a good fit. The frame can be returned to plane in a similar manner.
2. Corrosion may be so great that the proper closing of the sash is not possible. In these conditions, grind the uneven portion of the frame or sash back to its original design plane.
3. Moderate corrosion may result in divots or uneven surfaces once the corrosion is removed. These can be filled with special epoxies impregnated with steel filaments that are designed for these repairs. We have used Ferrobond® products by Abatron, Inc. to good effect.

SEVERE CORROSION

Windows exhibiting severe corrosion (see Figure 7) can often be economically and effectively restored by qualified craftsmen with extensive field experience. Severe corrosion is evidenced by sections of the sash or frames that are corroded to the point they have no structural integrity, have severely deformed or misaligned frames or sash, or are missing metal sections. Again, all of the methods discussed to solve minor and moderate corrosion should be employed first.

1. Window sash and frames that exhibit severe corrosion typically must be repaired in the shop. As mentioned above, determine how much of the window can be economically dismantled and treated off-site.
2. Once in the shop, abrasive blasting is the best way to remove paint and corrosion. This allows a very clean surface for welding patches or applying steel-filled epoxy.
3. Severe corrosion as pictured in Figure 7 can be repaired by cutting away material back to the solid metal. New metal is then welded to the old and ground down to the original profile. The result can be seen in Figure 8.
4. Deflected or misaligned sashes and frames can be effectively straightened in the shop employing vises, clamps, come-alongs, and use of heat.

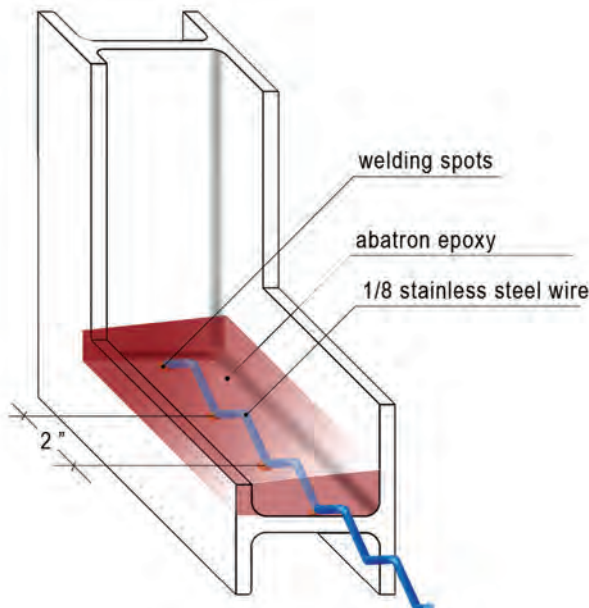

Figure 9 – Augmenting water-shedding capabilities.

5. Check all tapped fastening points. If corroded, weld shut, redrill, and tap if the fastening location cannot be moved.
6. Check initial documentation, and note where standing water occurred and corrosion was most severe. At Nealon, we found that all of the lower sections of the frames were severely corroded. This was due to the design that created a water trap. Our repair to these sections corrected this original design flaw. We filled the trough of this section with epoxy filler that was pitched to the exterior. We reinforced this repair with stainless steel $\frac{1}{8}$ -in. wire that was welded to the steel frame (see *Figure 9*).
7. Cast-iron ornamentation was one of the distinguishing features of the windows at Nealon; it was decorative and not part of the supporting structure. Many of the sections were damaged or had missing segments. It is imperative to retain as much of the original fabric as possible. We

cast iron repair

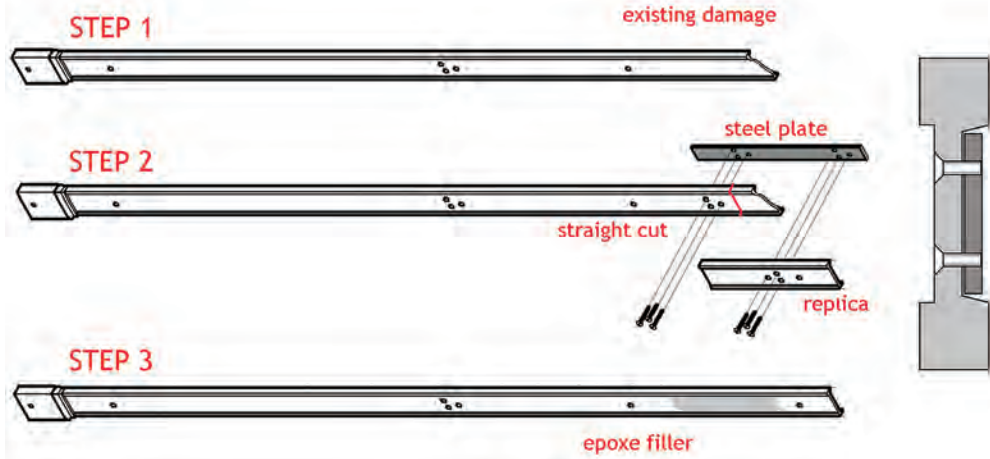

Figure 10 – Cast iron repair.

had runs of the different profiles cast. We cut the damaged sections from the cast iron and cut pieces of the new iron to fit, attaching them with stainless-steel splints (see *Figure 10*). We also made a number of tungsten inert gas (TIG) weld repairs to the cast iron, employing a silicon bronze rod.

8. The subframe assembly at Nealon had to be repaired in situ. This involved the cutting out and replacement of sills and headers. We had runs of the various profiles fabricated. At the site, damaged sections were cut away, leaving plumb and straight edges. New sections were cut and welded in place. After tack



Figure 11 – Sub-frame repair in process. Replacement section tack-welded in. There is a steel backing plate that spans the joint. Welds will be made continuous along the joint and ground flat to the profile. Where required, epoxy patch material will be added.

weld, the full bead was welded, ground flat, and filled with epoxy putty (see Figure 11).

9. When all repairs are complete, the finished steel is given a light blasting to clean away any corrosion that has formed during the shop work. The metal should be immediately painted with a rust-inhibitive primer. It is important that the complete paint system come from a single manufacturer. We chose Tnemec and used a Series 1 Omnithane primer for all plain steel and cast iron, the Hi-Build Epoxoline II primer for stainless steel, and the Flouranor satin as a top coat.

CONCLUSION

Steel window fenestration is often a defining feature of a historical building. If so, all reasonable attempts should be made to restore and preserve the windows. If the windows have not suffered extensive, severe corrosion and rust jacking, the cost of restoration can often be competitive with replacement with new windows. Proper sealing of

the windows and the addition of weather-stripping can greatly reduce air infiltration, the primary cause of heat loss in windows. Thermal efficiency can be further enhanced by the addition of interior storms. If properly maintained, steel windows can offer a very long service life. Beyond the as-found conditions of the windows, it is imperative to put together a knowledgeable and experienced team of preservation professionals to ensure a successful project. 

BIBLIOGRAPHY

Peter Clement. "Metal Windows." *www.buildingconservation.com*. Cathedral Communications Limited. 1998. <http://www.buildingconservation.com/articles/metalwin/metalw.htm>. This article is reproduced from *The Building Conservation Directory*, 1997.

Eleni Makri. "Wrought Iron and Steel Windows." Cathedral Communications Limited. 2012. <http://www.buildingconservation.com/articles/iron-steel-windows/iron-steel-windows.htm>.

Sharon C. Park, AIA. "Preservation Brief 13: The Repair and Thermal Upgrading of Historic Steel Windows." 1984. U.S. Department of the Interior, National Park Service, Cultural Resources.



Arthur J. Femenella Sr.

Arthur Femenella Sr. has over 45 years of experience in the field of window restoration. He is the president of Femenella & Associates, Inc., a full-service stained glass, historical wood, and steel window conservation studio he founded in 1993.

Femenella has published over 50 articles about window restoration and lectured extensively both in the U.S. and abroad. He is active in many preservation groups. The firm is an approved provider of AIA/CES learning credits.

NRCA Implements Career Center

The Bureau of Labor Statistics (BLS) projects an 18% increase in the need for roofing workers by 2020. The Latino roofing workforce has reached an all-time high of 58.1%, according to February 2015 data from the BLS. To address the issue of a labor shortage in the industry, the National Roofing Contractors Association (NRCA) has implemented a new online career center.