

Changes to FM Global Data Sheets Related to Wind and Roofing

By Richard J. Davis, PE, FSFPE

This article summarizes revisions that have either recently been made or are in the process of being made to FM Global Property Loss Prevention Data Sheets (data sheets) related to wind or roofing. As is the case with all data sheets, significant changes are listed in Section 1.0 of each document. Data sheets are available free of charge at www.fmglobalsheets.com. The revision cycle varies depending on how dynamic the subject matter is, but generally ranges from two to five years. The website should be checked periodically for updated data sheets.

DATA SHEET 1-28, "WIND DESIGN"

This document was revised and published in October 2015. Significant changes include the following:

1. Optional guidance was added for tornado-resistant design. This information can be found in Appendix D and is provided for property loss prevention purposes only. Recommended design wind speeds are noted for the United States. Criteria for determining the wind design pressure are included, and the use of windborne debris-resistant windows (among other things) is recommended. Readers are referred to the Federal Emergency Management Association's FEMA P-320 and FEMA P-361 for guidance regarding the design of tornado shelters.
2. An explanation of differences in the design criteria between Data Sheet 1-28 (based on the American Society

of Civil Engineers' ASCE 7-05 and on allowable strength design or ASD) and ASCE 7-10 (which is based on ultimate wind speed design) was added. This is discussed in

Sections 2.7 and 3.10, including an example. Changes were not made to Data Sheet 1-28 to comply with ASCE 7-10 at this time, as additional changes will be made in ASCE 7-16, which is to be published later this year. Revisions to Data Sheet 1-28 are planned in the not-too-distant future to reflect changes in ASCE 7-16. For example, there will be significant changes in ASCE 7-16 related to low-slope ($\leq 7^\circ$), gabled roofs, which are commonly used for a very significant percentage of large industrial and commercial buildings. The target date for changes to be made to Data Sheet 1-28 is shortly after the publication of the

2018 revision of the International Building Code (IBC-2018).

3. Additional guidance was added in Section 3.4 for less common roof shapes, such as mono-slope ($> 3^\circ$);

1-28

Page 28

Wind Design

FM Global Property Loss Prevention Data Sheets

B. For saw-tooth roofs with roof slopes of more than 10° , multiply the basic wind pressures in Tables 3, 4, or 5 in Section 3.3 by their respective normalized pressure coefficients in Table 3.4.2a. See Fig. 3.4.2a for Zone dimensions. Define "a" as the lesser of 10% of the lesser plan dimension or 40% of the roof height, but not less than 4% of the least horizontal dimension or 3 ft (0.9 m). As the roof slope is more than 10° , use h = the mean roof height.

Note that Zone 3, where the peak occurs, is rectangular with dimensions $2a \times a$, with the long dimension running along the roof peak (see Fig. 3.4.2b) and that the Zone 3 pressures are higher for the first saw-tooth (Span A) than for the remaining ones (Spans B, C, D, etc.).

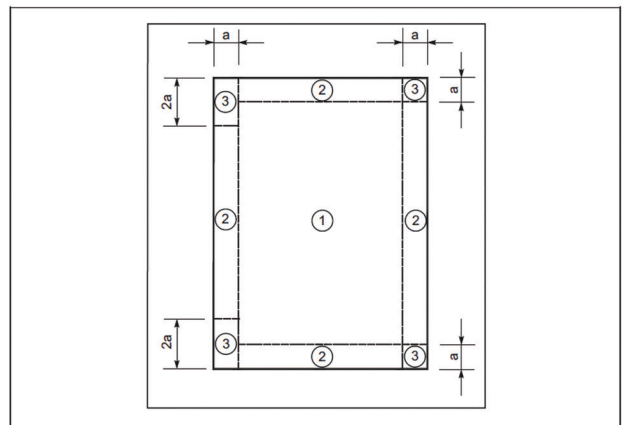

Fig. 3.4.2a. Zone 2 and 3 dimensions for saw-tooth roofs with slopes of more than 10°

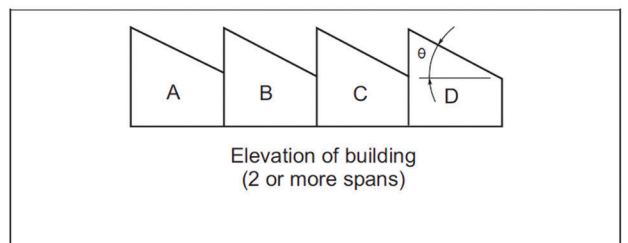

Fig. 3.4.2b. Elevation view for saw-tooth roofs with slopes of more than 10°

Figure 1 – Revisions to Data Sheet 1-28 discuss sawtooth roofs and wind pressures. © FM Global. Reprinted with permission.

sawtooth; steep-slope, multigabled, arched roofs; and domes. Guidance is based on the pressure coefficients in ASCE 7, but is presented in a simpler format. (See *Figure 1.*)

4. Additional guidance on topographic factors (K_{zt}) was added, with reference to Data Sheet 1-8, "Antenna Towers and Signs," which covers that subject in more detail. For relatively flat terrain (ground slope $<10^\circ$), K_{zt} may be assumed to be 1.0, thus not increasing the design wind pressure. Similar guidance as it relates to the New Zealand wind code was also expanded.
5. Additional wind speed information was added for the islands of Australia, and the wind map for Western Mexico was updated.
6. The formula for estimating the travel distance of potential small wind-borne debris (roof aggregate) was revised. This can be used to determine the needed separation between an existing source building and new construction to determine where

protection is needed for exposed windows, or to justify the removal of existing roof aggregate from the source building.

7. Guidance related to ground roughness and roof overhangs was clarified. The use of ground roughness D is now recommended in all coastal areas, regardless of the design wind speed. This is now consistent with current guidance in ASCE 7 (2010 and 2016). Previously, the use of ground roughness C was accepted in coastal regions when the design wind speed (V) was ≥ 120 mph (54 m/s).
8. The minimum elevation difference recommended to treat abutting buildings as separate buildings (with regard to perimeter and corner wind design enhancements) was increased from 3 ft. (0.9 m) to 10 ft. (3 m) for consistency with ASCE 7 (2010 and 2016).
9. Guidance for structural engineers for the anchorage of roof-mounted equipment was updated to reflect

very recent test data that were not available in time for consideration in the ASCE 7-16 cycle.

10. Additional guidance was added related to emergency power generating systems.

DATA SHEET 1-29, "ROOF DECK SECUREMENT AND ABOVE-DECK ROOF COMPONENTS"

This document was revised in January 2016, and further editorial changes were made in April 2016. Significant changes include the following:

1. The document was reformatted and simplified.
2. Several tables were added to facilitate the determination of proper steel deck spans for various wind design pressures. Tables are now provided for both uniformly applied wind loads and concentrated wind loads. Uniform wind loads include adhered roof covers and mechanically fastened roof covers (MFRC) where the distances between rows of roof covers are no more than half the deck

SPRINGLOK FLASHING SYSTEM

PROTECT THE INTEGRITY OF YOUR ROOFING ASSEMBLY

Fry Reglet's "Reglet & Springlok™ Flashing System" provides the ultimate in roof protection from moisture intrusion and wind uplift. (Per ASTM D3161 Class F 110MPH Test)

For stucco finishes, our "STX Reglet" with a 3 1/2" attachment flange provides the perfect amount of space for WRB's without additional accessories.

Specify Fry Reglet Today.

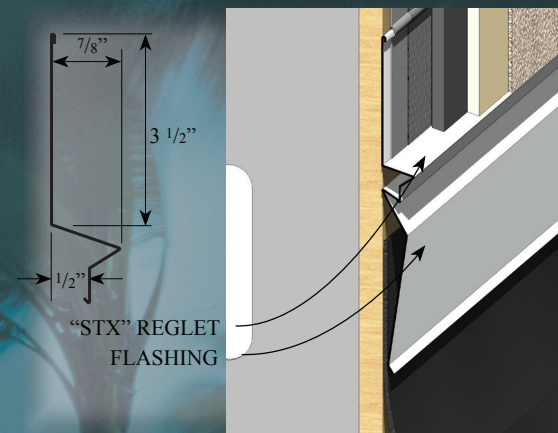

span. Concentrated wind loads include MFRC where the distance between rows of roof cover fasteners is greater than half the deck span. The steel deck span tables cover the range of steel deck thicknesses normally found, including 22-, 20-, and 18-gauge. (See Figure 2.)

- Guidance for steel deck securement was modified.
- Guidance regarding preliminary insulation or cover board securement used with MFRC was expanded considerably, resulting in reduced fastener requirements in some cases where vapor retarders are used.

DATA SHEET 1-28R/1-29R, "ROOF SYSTEMS"

This data sheet is a reference document that provides supporting information for Data Sheets 1-28 and 1-29, and was revised in January 2016. Changes were mostly editorial in nature, and updates were made to the table listing mechanical properties of various steel decks.

DATA SHEET 1-31, "PANEL ROOF SYSTEMS"

This document was revised and published in July 2016. Significant changes include the following:

- The title was changed from "Metal Roof Systems" to "Panel Roof Systems" to include the wind design of FM Approved plastic panels and composite panels, such as insulated roof panels with a metal bottom facer and a thermoplastic roof cover on top of the insulation core. These systems are tested and FM Approved in accordance with FM 4471.
- Guidance was added regarding the use of external seam clamps (ESCs) to increase the wind resistance of

Table 1C. Maximum Steel Deck Span (ft) for 1½ in. (38 mm) Deep, Wide Rib (Type B) Steel Deck with an Adhered Roof Cover, for Wind Ratings from 60 to 225 psf (2.9 to 10.8 kPa)

(NOTE: Use this table when the distance between rows of roof cover fasteners is one-half the deck span or less. Green font indicates that deflection governs over bending stress.)

Yield Stress psi	Deck Gauge	Ultimate Wind Rating per RoofNav (psf)											
		Maximum Span (ft)											
		60	75	90	105	120	135	150	165	180	195	210	225
33,000	22	7.10	7.10	7.10	7.10	7.07	6.67	6.33	6.03	5.78	5.55	5.35	5.17
	20	7.78	7.78	7.78	7.78	7.78	7.43	7.05	6.72	6.44	6.18	5.96	5.76
	18	9.08	9.08	9.08	9.08	9.08	8.66	8.22	7.84	7.50	7.21	6.95	6.71
	16	10.36	10.36	10.36	10.36	10.36	9.89	9.38	8.94	8.56	8.23	7.93	7.66
40,000	22	7.10	7.10	7.10	7.10	7.10	7.10	6.96	6.64	6.35	6.10	5.88	5.68
	20	7.78	7.78	7.78	7.78	7.78	7.78	7.76	7.40	7.08	6.80	6.56	6.33
	18	9.08	9.08	9.08	9.08	9.08	9.08	9.04	8.62	8.25	7.93	7.64	7.38
	16	10.36	10.36	10.36	10.36	10.36	10.36	10.32	9.84	9.42	9.05	8.72	8.43
45,000	22	7.10	7.10	7.10	7.10	7.10	7.10	7.10	7.04	6.74	6.48	6.24	6.03
	20	7.78	7.78	7.78	7.78	7.78	7.78	7.78	7.78	7.51	7.22	6.95	6.72
	18	9.08	9.08	9.08	9.08	9.08	9.08	9.08	9.08	8.76	8.41	8.11	7.83
	16	10.36	10.36	10.36	10.36	10.36	10.36	10.36	10.36	9.99	9.60	9.25	8.94
50,000	22	7.10	7.10	7.10	7.10	7.10	7.10	7.10	7.10	6.93	6.66	6.42	6.20
	20	7.78	7.78	7.78	7.78	7.78	7.78	7.78	7.78	7.72	7.42	7.15	6.91
	18	9.08	9.08	9.08	9.08	9.08	9.08	9.08	9.08	9.00	8.65	8.33	8.05
	16	10.36	10.36	10.36	10.36	10.36	10.36	10.36	10.36	10.28	9.87	9.51	9.19
55,000	22	7.10	7.10	7.10	7.10	7.10	7.10	7.10	7.10	7.10	7.10	7.10	6.97
	20	7.78	7.78	7.78	7.78	7.78	7.78	7.78	7.78	7.78	7.78	7.78	7.69
	18	9.08	9.08	9.08	9.08	9.08	9.08	9.08	9.08	9.08	9.08	9.08	8.97
	16	10.36	10.36	10.36	10.36	10.36	10.36	10.36	10.36	10.36	10.36	10.36	10.24
60,000 +	22	7.10	7.10	7.10	7.10	7.10	7.10	7.10	7.10	7.10	7.10	7.10	7.10
	20	7.78	7.78	7.78	7.78	7.78	7.78	7.78	7.78	7.78	7.78	7.78	7.77
	18	9.08	9.08	9.08	9.08	9.08	9.08	9.08	9.08	9.08	9.08	9.08	9.06
	16	10.36	10.36	10.36	10.36	10.36	10.36	10.36	10.36	10.36	10.36	10.36	10.34

Green font indicates that deflection governs over bending stress.

Figure 2 – Revisions to Data Sheet I-29 include proper deck spans for various wind design pressures.

standing-seam metal roofs (SSRs). Prescriptive alternatives for perimeter and corner enhancements were revised to recommend the use of ESC in corner areas (where the field-of-roof design wind pressures are >90 psf) and in the perimeter and corner areas (where the field-of-roof design wind pressures are >135 psf). The importance of using ESCs that properly fit the particular SSR seam was emphasized. Also discussed were methods to install ESC without restricting the normal accommodation for thermal expansion that is provided with SSR.

DATA SHEET 1-34, "HAIL DAMAGE"

This document was revised in October 2014. Significant changes include the following:

- A Very Severe Hail (VSH) region was added to the hail map for the United

States. This region includes North Texas, Oklahoma, and Kansas. Counties considered to be in North Texas for design and analysis purposes are shown in a table. FM 4470 is being revised to address VSH region testing for single-ply and multi-ply roof covers, and new listings are expected in the near future.

- Information on hail test standards was added.
- Emphasis was put on the use of FM Approved products that are properly hail-rated for the region in which they are located.

DATA SHEET 1-49, "PERIMETER FLASHING"

This document is currently being revised, with publication planned for October 2016. Significant changes include the following:

- Guidance will be added to facilitate the selection of FM Approved flash-

- ing systems.
- Prescriptive guidance for the design and installation of perimeter flashing systems will be deleted.
 - Guidance for the securement of perimeter wood nailers will be expanded and will include installations where the field-of-roof wind design pressure exceeds 90 psf.

**DATA SHEET 1-26,
“STEEP-SLOPE ROOFS”**

This is a new data sheet that is currently being developed, with publication planned for April 2017. It will address roofs that are typically used with slopes $\geq 10^\circ$. This document will provide the following information:

- Wind-related guidance for asphalt shingles, concrete and clay tile, and slate. These products are (or can be) FM Approved in accordance with FM 4475. The wind component of that standard is based on ASTM D3161. Unlike other wind tests and ratings, which are based on wind pressure, these tests and listings are based on wind speed. Wind maps only reflect conditions at roof heights of 33 ft. (10 m) and open terrains (ground roughness C). Roof height and ground roughness exposure will also be considered in tables that simplify the selection of the properly wind-rated shingles or tiles.
- Guidance will be given on how to select the appropriate steep-slope roofing material with the needed hail rating.

**DATA SHEET 1-33,
“SAFEGUARDING TORCH-APPLIED
ROOF INSTALLATIONS”**

This document is currently being revised, with publication planned for sometime in 2017. The revision is intended to update training requirements for torch-applied roof installers. 

REFERENCES

**FM Global Property Loss Prevention
Data Sheets**

- 1-8, “Antenna Towers and Signs.” July 2011.
- 1-28, “Wind Design.” October 2015.
- 1-29, “Roof Deck Securement and Above-Deck Roof Components.” April 2016.
- 1-28R/1-29R, “Roof Systems.” January 2016.
- 1-33, “Safeguarding Torch-Applied Roof

- Installations.” January 2000.
- 1-34, “Hail Damage.” October 2014.
- 1-49, “Perimeter Flashing.” October 2016.

FM Approval Standards

- FM 4470, “Single-Ply, Polymer-Modified Bitumen Sheet, Built-Up Roof (BUR) and Liquid Applied Roof Assemblies for Use in Class 1 and Noncombustible Roof Deck Construction.” June 2012.
- FM 4471, “Class 1 Panel Roofs.” March 2010.
- FM 4473, “Specification Test Standard for Impact Resistance Testing of Rigid Roofing Materials by Impacting with Freezer Ice Balls.” July 2005.
- FM 4475, “Approval Standard for Class 1 Steep-Slope Roofs.” August 2015.

American Iron and Steel Institute (AISI)

AISI S100, *North American Specification for the Cold Formed Steel Structural Members.* 2012.

**AMERICAN SOCIETY FOR TESTING
AND MATERIALS (ASTM)**

- ASTM D3161, *Standard Test Method for Wind Resistance of Steep-Slope Roofing Products (Fan-Induced Method).*
- FEMA P-320, “Taking Shelter from the Storm: Building a Safe Room for Your Home or Small Business.”
- FEMA P-361, “Design and Construction Guidance for Community Safe Rooms.”



Richard Davis,
PE, FSFPE

Richard Davis is a senior engineering technical specialist with FM Global’s Engineering Standards Division in Norwood, MA, for which he has worked for 42 years. He earned a bachelor’s degree from Lowell Technological Institute and a master’s from Worcester Polytechnic Institute. Davis is a past president and a fellow of the Society of Fire Protection Engineers (SFPE), and also past president of its New England Chapter. He is a member of the International Code Council and is active with the National Fire Protection Association.

Wind Load Tested Retrofit by

ROOF HUGGER®





MEMBER OF

- Specified by RCI members nationwide
- Fully-engineered to meet new codes
- Strengthens existing purlins
- CAD details & editable specifications
- Free design and budget estimates



800-771-1711
www.roofhugger.com

*Celebrating 25 Years with
70 Million Square Feet!*