

Using Rubber Extrusion to Drive Quality in EPDM Manufacture



By Rick Gustin

Figure 1 – EPDM pellets dropping into the extruder.

Since it was first introduced to the industry in the late 1970s, roof consultants have come to recognize the advantages of EPDM single-ply membrane for low-slope commercial roofs. The technical term for this highly durable and weather-resistant material is “ethylene propylene diene monomer.” However, it is typically known by its acronym: EPDM.

Johns Manville (JM) has manufactured roofing materials since 1858, and it began selling and marketing EPDM in 1982.

CALENDERING: A TRADITIONAL MANUFACTURING TECHNIQUE

The process of using a “calender” to flatten rubber into thin sheets has been around for more than a century. In this process, heat-softened rubber polymer is forced through two or more rollers to create a sheet, and the resulting roof membrane—the EPDM—is then rolled, cured, packaged, and transported to project sites for installation (Figures 2 and 3). While this technique

and the resulting membrane were acceptable for the construction industry for many years, over time, limitations inherent to the calendaring process have become evident.

According to the online research site *Appropedia*, “To begin the process, the polymer must go through blending and fluxing before it goes through the calender. Blending is a process that creates the desired polymer and fluxing heats, and works the blended polymer to make it a consistency easier for the calender to handle. The polymer is then sent through the calender, and its thickness is dependent on the gap between the last two rollers.”

Though the calendaring equipment has improved since the introduction of EPDM, the process does produce inconsistencies

Figure 2 – Simplified diagrams showing traditional calendaring (above) with a rolling bank and material under pressure in a roller-die extruder (below).

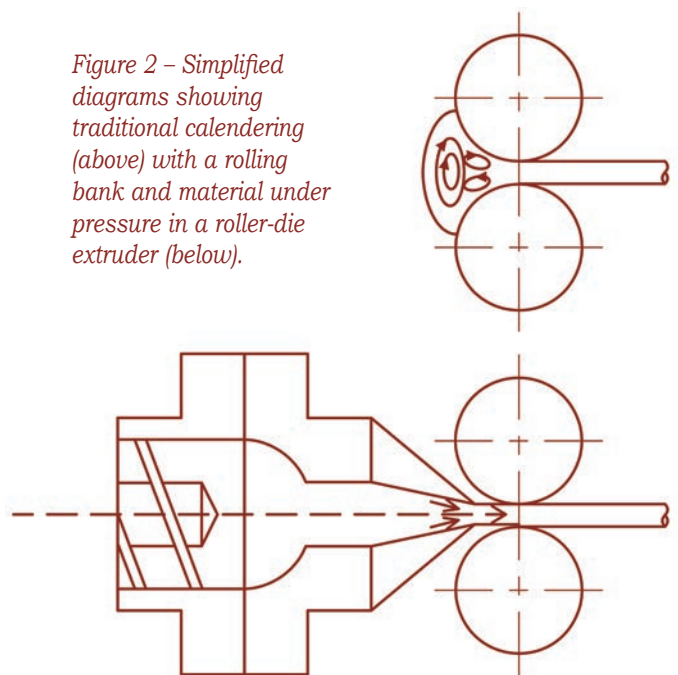
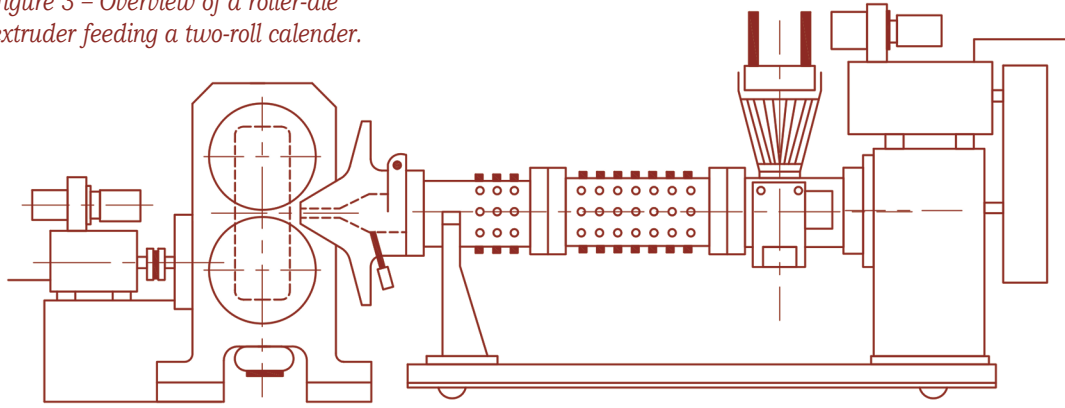

Figure 3 – Overview of a roller-die extruder feeding a two-roll calender.



in the finished sheets, especially in very thick and very thin gauges. According to the aforementioned article, “If the thickness is below 0.006 inches, then there is a tendency for pinholes and voids to appear in the sheets. If the thickness is greater than about 0.06 inches, though, there is a risk of air entrapment in the sheet.”

EXTRUSION: MODERNIZING THE PROCESS

In 2012, JM opened its own manufacturing facility for EPDM in Milan, Ohio, which is still the newest wide-sheet facility in the world. Instead of traditional calendaring, the plant uses state-of-the-art roller die extrusion equipment.

This technique has been tested and recalibrated many times in order to ensure the highest standards of membrane quality. There are, indeed, calender rolls on an extrusion line, but they are post-blending. For the purpose of this paper, “calendering” is used when describing how the polymer and formulation are blended prior to moving to the sheeting process.

The process starts by creating the formulation from raw materials. Once the various ingredients are mixed together into uncured rubber, it is ready to be processed into uncured sheets. EPDM is often made by producing two thinner sheets that are cured together to make one; this redundancy creates a higher-quality product. During this process, two separate extruders are used

(Figure 4).

After mixing, the hoppers at the extruders are loaded with material that can be in the form of pellets or slab. From there, the material enters the feed throat of the extruder and goes through a scraper that removes any material that sticks to the screw or starts to reverse. Inside the screw itself, there are multiple rows of pins that are spaced throughout the extruder. The pins are used to combine and masticate the material together and can be configured to adjust where the most intense mixing occurs.

This point of the process is controlled using temperature control units (TCUs) on the screw in the extruder, as well on the walls along the various zones in the extruder barrel. The

JM Employs Approximately 100 at Its EPDM Facility in Milan, Ohio.

Milan Plant Is the Newest Wide-Sheet Facility in the World

The JM EPDM manufacturing facility opened in May 2012 in Milan, Ohio, employing roughly 100 people. “It was a tremendous investment for us, as EPDM is extremely capital-intensive,” said Director of Single-Ply Marketing Jennifer Ford-Smith. Ford-Smith noted, “The support from the organization’s leadership and the commitment from every employee involved was what led the successful implementation.”



Director of Operations Brian Olson said, “The company had tremendous support of the local Milan community. We were able to build on our established reputation in the state of Ohio because of our success with our other manufacturing locations in Defiance and Waterville, Ohio.”



Figure 4 – Extruder in an EPDM roofing plant. Two extruders are utilized—each making a separate sheet that will become one homogenous membrane.

TCUs are used to maintain a temperature at which the rubber flows without adding unnecessary heat to the mix. The goal is to blend the material together while avoiding curing it. In addition, there is a differential temperature between the wall and the screw to aid in the material flow process. The material then passes over a temperature sensor at the end of the extruder that monitors the rubber temperature as it is leaving the screw and entering the die. The die is configured with temperature control on the top and bottom, again to avoid curing and to maintain flow.

At this point in the process, the material is fully blended, and



Figure 5 – EPDM material exiting the lip of the die.

LIQUID FLASH

APOC
Permanent
DETAIL
SEALANT



The Original and Best Performing Liquid Flashing

- ▶ Fast Install with up to 50% Labor Savings
- ▶ Ideal for Roofing, Waterproofing & Building Envelope Applications
- ▶ Solid Monolithic & Waterproof Configuration
- ▶ Use on Vertical or Horizontal Applications
- ▶ Available in Multiple Sizes & Containers



APOC
The Choice of Top Professionals®

www.apoc.com • (800)562-5669



Figure 6 – Extruded membrane prior to entering the doubling roll that will combine two layers into one membrane.

the goal is to use the die to expand the compound in preparation to make a sheet. As the material leaves the die (Figure 5), it goes through a set of lips that set the shape of the material before the final sheeting (post-blending calender) step of the process. The die lip design influences that particular compound's flow characteristics. The screw speed can be adjusted in order to maintain a constant feed rate—which, in turn, maintains a more consistent thickness profile, eliminating surging (common with traditional calendering).



Figure 7 – Extruded membranes have exceptional surface finish and consistency.

The material leaving the extruder is kept to a one-to-one ratio with the adjacent sheeting rolls (aka calender rolls), which eliminates a rolling material bank. It is simply pushed out through the die in the form required. Traditional calendering requires a large rolling material bank behind the rollers to keep the sheet from having voids or run-outs. The downside of this approach is that it can potentially

create a significant number of pockmarks or entrapped air. In addition, rolling banks increase unnecessary head cycles to the material, resulting in hot spots and/or scorching. Because the material may not turnover into the nip of the rolls, inconsistencies or cured lumps in the calendered sheet can result. Also, a calender is typically fed by one or more mills, which are used to

heat up the rubber by working it between two large rollers. The mills also entrap air in the rubber as it is processed. Adding extra temperature cycles and/or overworking the rubber material can cause premature heat aging, which potentially reduces the service life of the finished product. Calendered material also relies on operator involvement in blending the rubber, which introduces

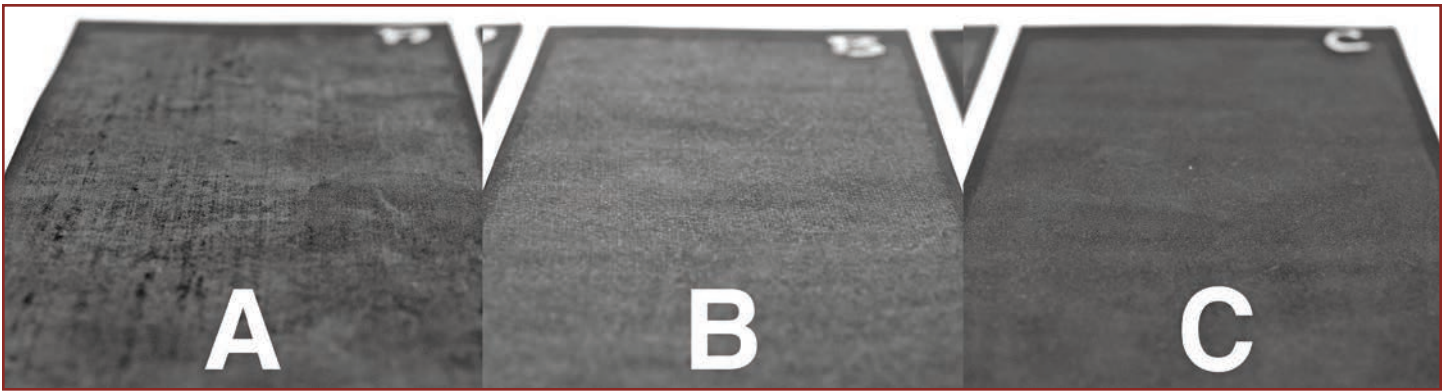

Figure 8 – Traditional calendered EPDM (A and B) alongside an extruded sheet (C).

other variables as a result of individuals' varying techniques.

A main advantage of the extrusion process is that it eliminates air gaps in the sheet (pockmarks) and minimizes precured lumps. It also allows for better temperature control of the uncured EPDM. The extruder has multiple areas of temperature control: screw, feed throat area, end of screw area, and die (top and bottom). All of these areas can be heated or cooled as necessary to minimize scorching of the material, thereby reducing cured lumps. That is not easily done with traditional warm-up mills.

The calender rolls are also fitted with temperature control to cool the rubber quickly and to minimize the rubber sticking to the rollers. The material is trimmed to width after it goes through the calender rolls and is processed through a doubling roll that combines the two half-mill sheets (Figure 6). This roller is kept at a fixed temperature and pressure to ensure consistent lamination. Throughout the remainder of the process, the rubber is kept in nearly constant contact with a surface, with the goal of minimizing stretching and deformation. The sheet is monitored via thickness gauges. These gauges blow air on the sheet and monitor the backpressure and distance between the axes of the rollers to calculate the thickness. The sheet is also monitored with a grayscale visual defect system. The system works by looking at the sheet and taking a reference image to compare against every five minutes. If a difference is noticed on the sheet, it will alert the operator to the issue. As a result, extrusion delivers tighter uniformity of thickness across the sheet to provide a subtle but critical difference from calendering. This difference leads to enhanced seam performance and increased longevity of the membrane.

I'M SMALL ...
BUT HAVE A BIG APPETITE

ARE ELECTRICITY PEAK DEMAND CHARGES TAKING A BITE OUT OF YOUR BUDGET?

With 1,440 minutes in a day, how can usage from just 15 peak-use minutes account for a third of your energy bill? Utilities charge a much higher rate for that interval than for the other 99% of the day. Find out how peak demand charges are computed. Then spend 15 minutes checking out roof reflectivity's role in reducing your energy bill.

PUT DEMAND CHARGES ON A DIET.
LEARN MORE AT VINYLROOFS.ORG/PEAK-ENERGY-DEMAND

LESS LABOR WITH HIGHER QUALITY

Since the finished material is more uniform and has little or no surface porosity or air pockets within the EPDM, less backing material or parting agent is needed to keep the sheets on the rolls from sticking together during the vulcanizing process. This means there is less employee time required to prepare the membrane for installation, and the contractor has a much better chance of getting a stronger seam, removing some margin of error. Less time spent preparing the membrane means potentially lower labor costs.

During a time when the building trades—especially roofing—are experiencing a critical shortage of labor, having a membrane that is easier and quicker to install and allows a crew to do more work in less time is of paramount importance to a contractor's bottom line.

GREATER CONSISTENCY FOR LONGER LIFE

Along with seam performance, a loss in mil thickness over time, which leads to thin spots or holes, is the most common failure

mode for an EPDM membrane. As previously noted, extruded sheets exhibit a more consistent, smoother surface—free of pockmarks, voids, or entrapped air, and yielding the full thickness consistently across the sheet (Figure 7).

Once exposed to the tough rooftop stresses of an ever-changing environment, any voids or pockmarks where there is a loss in thickness will be the most likely place for a failure to begin. Ultimately, this will result in a leak. By ensuring a consistent thickness across the sheet, an extruded membrane eliminates these potential problems, helping to extend the life of the roof system.

Furthermore, the consistent thickness results in a smoother sheet, leading to better lay-flat qualities. This enables easier installation on adhered systems, and appearance is enhanced due to lack of wrinkles or “waviness.” In comparing extruded sheets (C in Figure 8) to more traditional calendered products, the Milan-produced membrane was found to have 40% less thickness variation across the width.

With building owners' maintenance budgets constantly under pressure, using a membrane with fewer surface defects on the day of installation can lead to a longer service life and lower lifecycle costs. 



Rick Gustin

Rick Gustin became the EPDM product manager for Johns Manville in 2013 and played a pivotal role in developing their pretaped FIT product. Rick started his career in the contractor community before coming to Johns Manville in 1998,

where he held various roles, including Six Sigma Black Belt and application engineer before assuming responsibility as manager of Guarantee Services. Rick graduated from Rensselaer Polytechnic Institute in 1996 and holds a degree in mechanical engineering.



www.rci-e-learning.org



*At your own pace,
on your own time, at your fingertips ...*

- Roof Drainage Design
- Roof System Thermal and Moisture Design
- Roofing Basics
- Roofing Technology and Science I
- Roofing Technology and Science II
- Rooftop Quality Assurance
- Wind Design for Low-Slope Roofs - Part I: Understanding ASCE 7-05 Wind Load Calculations for Members
- Wind Design for Low-Slope Roofs - Part I: Understanding ASCE 7-10 Wind Load Calculations
- Wind Design for Low-Slope Roofs - Part II: FM Global Guidelines and Best Practice Considerations

Online Educational Programs