

A Case History Review of ETFE on Today's Current Projects

By Lee Durston and Shawn Robinson

This article is republished from the proceedings of RCI's Building Envelope Technology Symposium, held October 17-18, 2016, in Houston, Texas.

ABSTRACT

ETFE, the fluorocarbon-based polymer ethylene tetrafluoroethylene, is quickly gaining popularity in North America and being used on some of the continent's most prominent projects. ETFE was developed for architectural purposes in the 1970s, and since that time, mainstream use of ETFE in construction projects has been largely limited to Europe. The material has many attractive attributes that provide not only a new aesthetic quality, but also potential cost savings. Weighing in at roughly one percent of the weight of glass, significant reductions in structural costs are made possible by employing ETFE. Despite these great potential benefits, the material is not an equal substitution to glass or other roofing systems in many respects. Through review of material characteristics, performance modeling, and multiple case studies of current ETFE installations, the authors will discuss lessons learned, limitations, and the benefits of the material from the perspective of building science implications.

ETFE History

In the late 1940s, DuPont developed ETFE and worked to define an appropriate end use for the material. Not surprisingly, architecture did not get the first look. One

of the first explored applications was insulation material for electrical wire, which needed to be resistant to friction and abrasion and immune to hostile environments such as radiation exposure and extreme temperatures. The product also found a specialized use in greenhouse applications and proved itself as a robust and stable material, resistant to tear and puncture, as well as the negative effects of UV, while transmitting the needed spectrum of light for plant growth.

In the 1980s, Stephan Lehnert, a mechanical engineer by trade, first investigated the use of the material as a ship sail material. After determining the ETFE foil was not an improvement to sail technology of the time, he explored its use as an architectural cladding and roofing material. Lehnert later went on to found Vector Foiltec in 1982, a design-build provider of ETFE systems worldwide. The first project with ETFE was a pavilion at a zoo located in Arnhem, Holland.

ETFE is considered to be in the family, or at least a distant relative, of tensile fabrics used in tensioned fabric structures. Unlike its tensile fabric cousins, it is neither a coated fabric nor a mesh fabric, but lends itself to many of the same design considerations. In the late 1950s, a man from New York by the name of Walter Bird formed a company called Birdair and began his pursuit of designing and constructing some of the world's most impressive tensioned fabric structures. As ETFE became

a relevant material, it was quickly adapted into Birdair's wheelhouse, and Birdair has continued to grow, with subsidiaries around the world.

Today, Vector Foiltec and Birdair are considered two of the largest ETFE design-build specialty contractors in the world. With ETFE increasingly being specified on a wide range of projects—from schools and offices to government buildings and sports facilities—the number of other competitors is rapidly proliferating. This increased competition has affected the manufacturing of the material, as well, and DuPont is no longer the only manufacturer of ETFE. The most well-known brand names of ETFE include Tefzel® by DuPont, Fluon® by Asahi Glass Company, and Neoflon® ETFE by Daikin, among others.

Foils to Cushion

ETFE has changed considerably from its first use as an electrical insulator material and takes on a much more eye-catching form in architectural settings. To make the material useful architecturally, the ETFE is extruded into thin sheets, referred to as foils. The thicknesses of individual foils can vary, but are typically between 2 and 12 mils (0.002 to 0.012 in.), depending on the performance requirements for given loading conditions. In multilayered applications, individual foils are perimeter-welded together and inflated to become a cushion. The most common applications in North America have included two- and three-foil

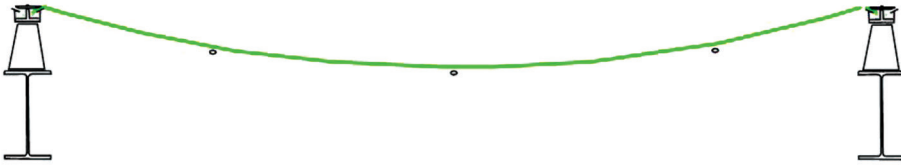

Figure 1 – A sketch diagram of a one-foil, cable-supported ETFE system.

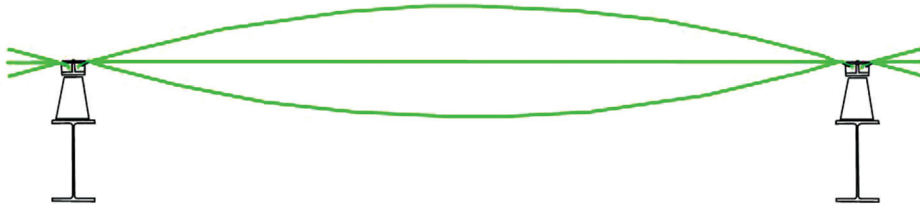

Figure 2 – A sketch diagram of a three-foil ETFE cushion.

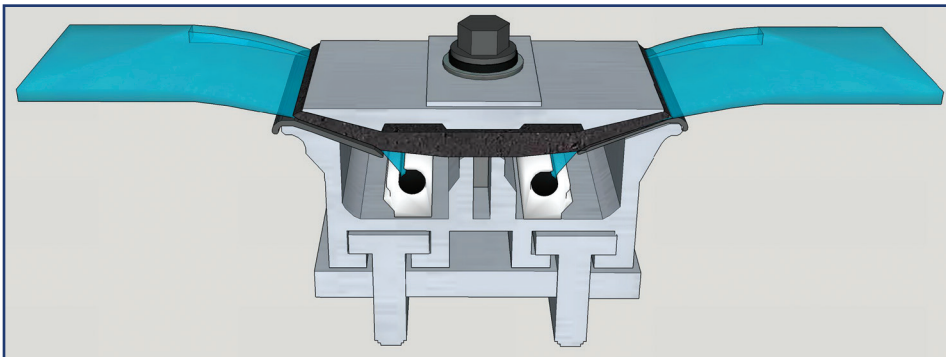

Figure 3 – 3-D model of generic ETFE rail and cushion system.

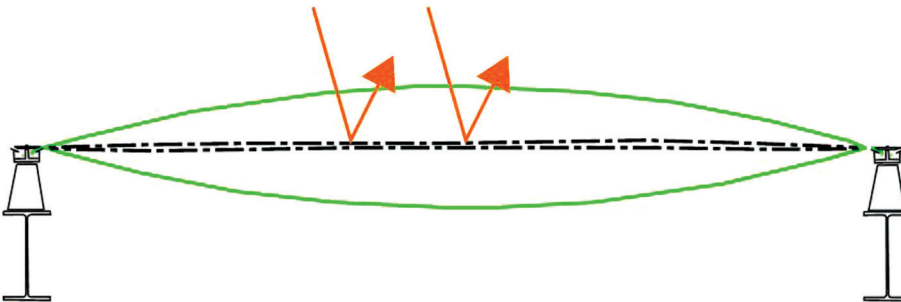

Figure 4 – Diagram sketch of a four-foil ETFE cushion (fritted foils shown as dashed lines) with lower pressurization between the second and third foil, closing the frit pattern and limiting solar access during the summer months.

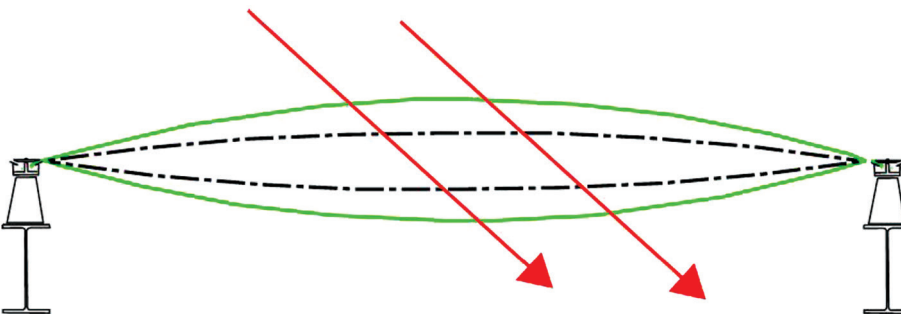

Figure 5 – Diagram sketch of a four-foil ETFE cushion (fritted foils shown as dashed lines) with higher pressurization between the second and third foil opening the frit pattern, allowing solar access during the winter months.

cushions, but single-layer installations do exist as well as high performance systems with up to five foils (Figures 1, 2, and 3). For a simplified comparison, the number of foils can be loosely compared to single-, double-, and triple-lite glazing units. In fact, ETFE systems are very similar in performance to glazed systems and are serving as an alternative option for these systems.

Insulation

Much like a glazed system, increased thermal performance is possible with a multilayered approach. When foils are formed into cushions, the pressurized air serves to stabilize the film and provides structural performance in addition to the thermal performance of the system. In a single-layered application, ETFE will achieve an approximate R-value of less than 1. A two-layer system will reach approximately R-2.0, and a three-layer ETFE system will have an R-value of approximately 2.9.

Transparency

ETFE films can be up to 95% transparent and allow for the passing of ultraviolet light, which is responsible for promotion of photosynthesis and facilitating plant growth. The amount of solar shading and transparency can be changed by adjusting the translucency, density, and number of layers, as well as the use of frit patterns. While colors can be introduced to provide a unique look for the ETFE, the ETFE is generally left transparent, with only a slight gray or white hue. In the end, it is no wonder why this material was first used as a greenhouse enclosure. With this new attribute, the potential for stadiums to be fully enclosed but have stationary natural turf becomes much more feasible.

Solar Control

ETFE foil systems can incorporate a number of frit patterns on one or multiple layers to alter their solar transmission performance. To achieve this effect, foils are printed with various standard or custom patterns and can provide varied levels of solar transmission or reflection. Depending on the angle of the sun (seasonal change), more or less solar gain can be planned (Figures 4 and 5). Much like solar shading outside of a glazed window system, the heat gain can be suppressed in the summer months and allowed in the winter months. In more advanced systems, pressurization of chambers can be raised and lowered

in order to move the internal foils, which essentially opens or closes the frit patterns based on operational needs.

Weight

Arguably the most economically desirable property of an ETFE foil system is its weight. Although you can barely measure the thickness of a single ETFE foil without a specialized instrument, when the material is built into a cushion, it expands to create a structural barrier several feet in depth. Weighing in at roughly 1% of the weight of glass, it can reduce the cost of the structural support system significantly. Even with the addition of the extra foil layers to produce an inflated cushion, aluminum extruded components, flashings, and an inflation tubing system, roof weights are often reported to be considerably lighter when compared to a glazed system.

Fire

Like many of the other plastic-type building materials, there is always a concern for how the material will behave in the event of a fire. The National Fire Protection Association's NFPA 285 has literally changed the direction of many projects, limiting material and system selections based on flame spread and surface burning characteristics. ETFE has undergone the full gamut of testing and has been rated under different national and international standards as self-extinguishing, with no melting or dripping of molten, burning material. When exposed to fire or temperatures above 500°F, the film simply melts away. The ETFE material is classified under several standards:

- ASTM E84, *Standard Test Method for Surface Burning Characteristics of Building Materials, Class A*
- UL 94VTM, *Tests for Flammability of Plastic Materials for Parts in Devices and Appliances—Thin Material Burning Test, Class 0*
- EN 13501-1, *Fire Classification of Construction Products and Building Elements—Part 1: Classification Using Data From Reaction to Fire Tests, Class B-s1-d0*
- NFPA 701, *Standard Methods of Fire Tests for Flame Propagation of Textiles and Films*

When ETFE is exposed to fire, it only melts and pulls away in locations where flame is in direct contact, which reduces the

risk of a fire spreading across the material or to other adjacent materials. In an atrium space, rather than containing and feeding a fire like a traditional roof system or even a glazed system, ETFE has the unique ability to self-vent the products of combustion to the atmosphere. Under fire conditions, any hot gases impinging on the cushions will cause the foil to soften, lose strength, and melt. In sample tests, it was observed that when exposed to flame, the ETFE will shrink back from the plume and disinte-

grate, venting the fire to the atmosphere. As the quantity of material used in the roof is so small and the ETFE is self-extinguishing, any material that falls from the roof or is swept upward will not burn occupants, first responders, or other materials, should it come into contact with them. This self-venting and self-extinguishing feature of ETFE prevents the buildup of high temperatures under the roof and can prevent catastrophic structural collapse of the primary structure.



I'M SMALL ...

BUT HAVE A
BIG APPETITE

ARE ELECTRICITY PEAK DEMAND CHARGES TAKING A BITE OUT OF YOUR BUDGET?

With 1,440 minutes in a day, how can usage from just 15 peak-use minutes account for a third of your energy bill? Utilities charge a much higher rate for that interval than for the other 99% of the day. Find out how peak demand charges are computed. Then spend 15 minutes checking out roof reflectivity's role in reducing your energy bill.

PUT DEMAND CHARGES ON A DIET.

LEARN MORE AT VINYLROOFS.ORG/PEAK-ENERGY-DEMAND

Acoustics

ETFE film also has about 70% acoustic transmission, making it ideal for projects in which loud noises are expected. During design development, sound transmission should be considered, as it will indeed transmit sound beyond the ETFE system and to the exterior of the building. Additionally, any sounds originating outside of the structure can be translated inward. In the case of rain on the roof ETFE assembly, it has the potential to sound more like a metal roof than a fabric roof.

Safety/Security

ETFE has a high resistance to deformation, but when that resistance is overcome, it has a high elasticity, which makes it an ideal building component where sudden extreme loads, such as earthquakes or blasts, could occur. Much like safety films that are placed on glazing, the ETFE is itself a standalone film that cannot shatter. The worst possible damage that could occur to ETFE under a shock-load situation would be a tear or a hole. ETFE will either deflect under load or—in the case of tearing—is unlikely to cause any major damage to other building components, property, or people.

In laboratory testing, ETFE has proven to be surprisingly puncture resistant. Projectile and “missile” testing of a three-foil cushion showed that a 2- x 4-in. stud traveling at 60 miles per hour rarely penetrated completely through after being shot at the cushion by an air cannon. Despite excellent performance under these conditions, ETFE is not overly resistant to being cut, and it is not recommended as vertical railing and should not be used at street or pedestrian levels, as it cannot prevent intrusion.

Additionally, any ETFE installation has the potential for damage and, like any roof, will need general ongoing maintenance. Access, repair, and maintenance are not routine, due to the unique characteristics and damage risks of the ETFE system. Because of this, the specialty design-build contractor will usually sign on for an extended warranty/maintenance period in order to perform this work.

Design Process

ETFE structures are generally specified as design-build projects or a subcontracted portion of a design-build project (delegated design) due to the unique characteristics of the system and the need for highly specialized and experienced designers. Throughout the design-build process, coordination is critical to the system’s overall aesthetics and performance. In general, the basic enclosure performance of the ETFE system is much like a curtainwall glazing system.

Performance: Air and Liquid Moisture

From a building science perspective, technical performance of materials, assemblies, and systems is mainly concerned with the control of four elements: 1) heat, 2) air, 3) moisture liquid, and 4) moisture vapor (known within the building science community as HAMM).

With today’s typical ETFE cushion and rail systems, much like a curtainwall glazed system, the main strategy for management of liquid moisture and air is a pressure seal created by the extruded cap plate and silicone gasket placed between ETFE cushions. In laboratory testing, as well as in-field testing, this general assembly has proven to be effective in creating an effective barrier for

air and water (moisture liquid). As with all systems of this type, workmanship is paramount for performance.

Performance: Heat

In general, the thermal performance of an ETFE system can be simplified to be approximately as good as assemblies used in similar situations. A cushion system with three layers of ETFE foil will achieve approximately R-2.9, while a five-layer system will achieve approximately R-4.8. This is similar to a thermally broken, glazed system; however, some key differences do exist. In a typical glazed system, the lites remain parallel and are accepted by the frame carrying the same R-value to the perimeter of the unit. In the ETFE system, the cushion is most thermally efficient at the center of the cushion and less thermally efficient closer to the edge of the cushion. As the cushion pinches into the extruded frame, the air space between the foils becomes smaller and smaller, until eventually, the separation between exterior and interior is simply the thickness of the number of foils included in the cushion. Without the air between the foils, the R-value for the system is minimal.

3-D thermal modeling was performed on a generic ETFE system to better understand the risk of interior condensation when utilizing a three-foil cushion in northern climates at various temperatures that could be experienced across the United States and Canada. (See *Figure 6*.) As noted, the least thermally insulating part of an ETFE assembly is near the cushion-to-frame interface, which corresponds to the location of highest condensation risk. As such, the team chose to model a typical section cut through a cushion-to-frame interface near a corner. The modelled section covers the intermediate mullion between ETFE cushions and the transition to the traditional single-ply roofing system.

Modeling was performed using the Nx software package from Siemens, which is a general-purpose computer-aided design (CAD) and finite-element analysis (FEA) package. The thermal solver and modeling procedures used for this study were extensively calibrated and validated for ASHRAE Research Project 1365-RP, “Thermal Performance of Building Envelope Details for Mid- and High-Rise Construction (1365-RP)” and guarded hotbox measurements. The thermal analysis utilized steady-state conditions and published thermal properties of materials. Glazing air cavities

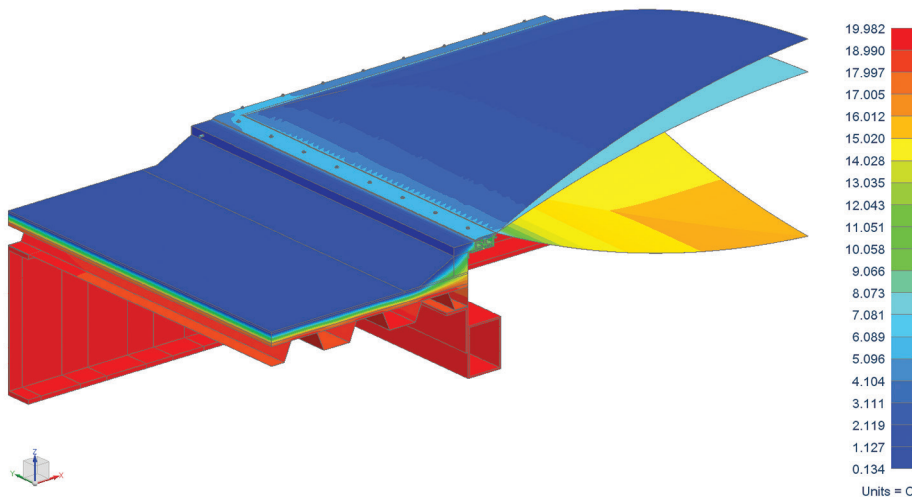

Figure 6 – Cross section of rail and cushion showing thermal gradient.

and film coefficients were based on ISO 10077-2:2003 (E), "Thermal Performance of Windows, Doors and Shutters – Calculation of Thermal Transmittance – Part 2: Numerical Method for Frames." Boundary conditions were modeled using heat transfer coefficients for convection (i.e., film coefficients). Radiation, to the interior and exterior, was directly simulated using assumed view factors and emissivity for the system.

The model was analyzed for four different exterior temperatures: 32°F, 14°F, 0°F, and -22°F (0°C, -10°C, -17.8°C, and -30°C). The interior temperature modeled was 68.9°F (20.5°C), which represents a conservative air temperature. For all temperature conditions, the exterior wind speed was modeled at 15 mph and set to nighttime conditions. This was taken as a "typical worst-case" set of wintertime conditions that do not include any influence from solar heating.

Performance: Moisture Vapor

The materials that are used in the ETFE cushion assembly are designated as Class I Vapor Retarders—essentially impermeable to vapor. Simply put, they have the potential to drastically slow vapor movement, and if the

temperature of the material reaches the dew point, condensation may occur. To understand the potential for condensation due to surface temperatures, the average steady-state conductive heat flow in three dimensions was analyzed.

It must be recognized that the objective of this analysis was not to predict in-service surface temperatures subject to variable conditions and/or heating systems. In-service surface temperatures of glazing systems are highly dependent on variable surface resistances and, as such, will vary from system to system. In contrast, the condensation risk was evaluated by determining surface temperatures subject to standard constant surface resistances for steady-state conditions.

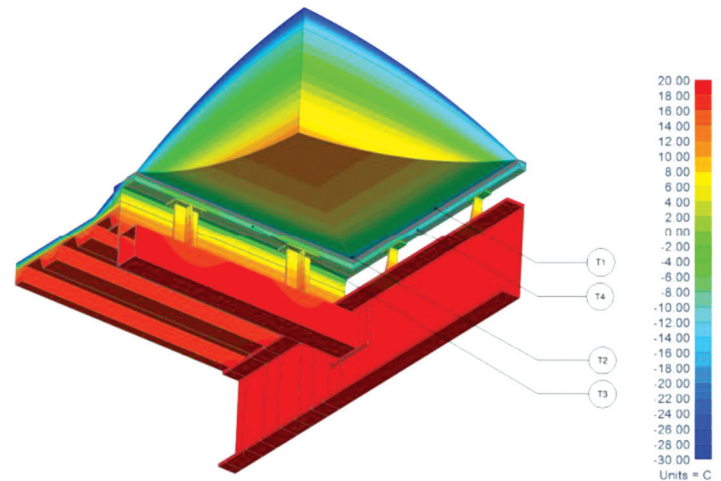

Figure 7 – 3-D thermal model of three-foil ETFE cushion in a northern climate at -22°F (-30°C).

Interior surface temperatures at key areas for evaluating the risk of condensation are highlighted in Figure 7. These areas include the coldest surface temperatures and locations with the greatest risk of condensation. The color isothermal plots illustrate the variation of the temperature viewed from the interior. T1 and T3 are along the intermediate mullion section, between two ETFE pillows, while T2 and

20 years of vegetated roof experience... brought to life in one app.



American Hydrotech introduces the Garden Roof® Planning Guide mobile app, a first-of-its-kind digital brochure that helps design professionals take a vegetated roof from initial concept to completion.

Packed with photography, technical information and videos, design professionals can explore assembly options and components, growing media and vegetation, and learn about topics such as design considerations, economic and sustainable benefits, installation and maintenance, and much more.

Download your copy today at hydrotechusa.com/GRPG



American Hydrotech, Inc.
303 East Ohio | Chicago, IL 60611 | 800.877.6125 | www.hydrotechusa.com

© 2016 Garden Roof is a registered trademark of American Hydrotech, Inc.

Exterior Temp (°F) (Celsius)	Location							
	T1 – Bottom ETFE Sheet Edges		T2 – Bottom ETFE Sheet Corner		T3 - Extrusion frame by SBS		T4 – Extrusion frame perp to SBS	
	Surface Temp (°F)	Max Allowable RH %	Surface Temp (°F)	Max Allowable RH %	Surface Temp (°F)	Max Allowable RH %	Surface Temp (°F)	Max Allowable RH %
32 (0)	44.4	43%	44.1	42%	48.9	50%	45.3	44%
14 (-10)	32.4	27%	32.0	26%	39.4	35%	33.8	28%
-0.4 (-18)	23.4	17%	22.5	17%	31.6	26%	24.8	19%
-22 (-30)	8.6	8%	7.7	8%	20.3	15%	11.3	10%

Figure 8 – Simulated surface temperatures at key locations.

T4 are at the transition between the ETFE and the metal deck roofing. T1 and T2 temperatures were taken directly on the ETFE pillow, 1 in. away from the framing.

Figure 8 summarizes the simulated surface temperatures at key locations for varying exterior temperatures that could be experienced in multiple locations and indicates the indoor relative humidity (RH) level at which condensation may occur (“Max Allowable RH%”). The table contains all the temperature scenario conditions described in the modelling procedures.

Morrison Hershfield (MH) found that in northern climates across North America, the likelihood of condensation occurring exists with a generic three-foil ETFE cushion system but will depend on not only what the expected interior humidity and heating conditions are but also convective or forced airflow patterns. During winter conditions, the humidity contribution from the exterior air used for interior ventilation may be low if there is not any additional moisture generation (humidification or occupant load). In this generic scenario, if the internal conditions for the ETFE atrium space are at or above 25% RH (depending on the expected moisture generation from occupancy), there may be some risks of interior frost formation when the exterior temperatures are below 14°F (-10°C). The extent of this formation will also depend on the length of time the exterior temperatures remain below 14°F.



Figure 9 – Manual removal of snow from an ETFE system. Photo credit: SurfaceDesign.

MH also found the adjacent assembly can impact the ETFE system’s ability to resist condensation, and this should be addressed on a case-by-case basis. As with many low R-value fenestration options, there are several strategies that could be further explored to reduce the risk of condensation, including using additional insulation to increase surface temperatures, increasing airflow at the ETFE system level using blowers, or using radiant heaters.

Wind, Rain, and Snow Management

As with any roof, a formal review of wind loads or wind study specific to the case roof’s geometries should be completed. The strength of the ETFE system will be designed and built appropriately to handle design pressures, but the structural support system must also be carefully designed. In many cases, the support system has been fine-tuned for weight consideration, and this must be balanced with the given loads



Figure 10 – An ETFE system in a deflated state, supported by snow cables, with snow load. Photo by SurfaceDesign.

for each area of the roof.

The roofing or cladding system needs not only to deflect the rain (and in some climate zones, snow), but the runoff or accumulation also needs to be managed. In typical roofing scenarios, perimeter drains or in-roof drains are often used. However, in ETFE systems, water drainage and management strategies are often much more complicated, as drains are unable to be hidden within the structure,

and transitions to gutters can present challenges.

In the case of a northern climate, certain complications exist with the formation of ice and accumulation of snow on the roof (Figure 9). While the cushions are pressurized according to the assumed design loads, in extreme snow and ice accumulation events, many times the design weight can overwhelm the cushion pressurization, and localized cushion deflation can occur. Due to this fact, the major manufacturers of ETFE systems have incorporated snow cables as a structural backup plan (Figure 10). These cables are designed into the system based on load potential at any given location, and are intended to support the intact but partially deflated cushion if the structural air within the system becomes overwhelmed. In the event of such a partial deflation, a second safety mechanism begins to take effect. While snow and ice can build up in a bowl-shaped, deflated

cushion, as the cushion deflates, it loses its thickness, structural air, and insulating value, and the interior heat of the building will begin to melt the ice or snow. Once melted, water will simply run off at the rim or low end of the perimeter extrusion. In this way, the system can react to localized areas of ice and snow buildup by lowering its R-value and melting the snow. The water is then easily drained, or a thin film of water beneath will better mobilize ice and snow off the roof. However, a heated interior and loss of heat are required for this mechanism to be effective. Once the high loads are relieved, the system automatically reinflates any affected cushions, restoring the system's insulating value.

Project-Specific Detailing and Holistic Process

In all cases, ETFE systems should be considered custom design-build aspects of the project. While the major manufacturers, designers, and contractors are beginning to understand efficiencies of reusing similar rail and cushion systems, the ETFE only serves as a portion of the enclosure; interfaces with adjoining materials, assemblies, and systems will always occur. To date, this proves to be the biggest hurdle to overcome when working with an ETFE system. Whether the ETFE is interfacing with a membrane roofing system, a curtainwall glazed system, metal panels, or even a brick veneer, the continuity of barriers needs to be maintained. In the case of an aluminum extrusion rail with a pressure cap, the adjacent material may lend itself to be fed directly under the cap plate of the system (for example, a single-ply roof membrane). In other cases, a more elaborate transition assembly may need to be developed in order to allow for movement and provide a traffic walkway. These interface details need to be fully coordinated with the complete team to minimize the risk potential.

Project-specific detailing will need to be approached in schematic design (SD), design development (DD), in the production of final contract documents (CD), and in shop drawings. As early as the SD phase, a formal wind study (and snow and ice, if in a northern climate) should be completed to understand the feasibility of ETFE roofing/cladding on the project, as well as to help guide project-specific detailing. Also in SD, the functional performance of the proposed ETFE assembly should be reviewed and tested, if warranted. Often, laboratory test-

ing (air, water, wind, condensation, blast, missile, etc.) of the proposed system has been completed in the past, and the results can be applied to a new project with review of laboratory testing reports. In the case of a custom fit, full assembly mock-ups should be constructed in order to demonstrate performance in laboratory testing. Ideally, any issues or concerns defined at this stage should allow ample time for adjustments or a significant change to assemblies. By the DD phase, the final ETFE assembly selection should be finalized, as well as

the adjacent systems to which the ETFE will interface. Once involved with CDs, it is recommended that the design team—often in conjunction with an enclosure consultant familiar with ETFE—bring the project-specific details to a final point, taking into account all of the conditions where the ETFE will interface with other assemblies. When CD detailing is not coordinated, the various trades' shop drawings often differ in means and methods, resulting in incompatible connections and/or scope gaps. In the absence of good detailing ahead of

It's a Roof Hatch... It's a Skylight... It's a Bilco.

Type GS Roof Hatch

All the security and convenience of a roof hatch with the added benefits of a skylight.

- Clear polycarbonate dome cover coated for UV resistance
- Translucent and double domes available when specified
- Fully gasketed design ensures weathertightness
- The safe and reliable operation that you have come to expect from a Bilco roof hatch



The natural daylight is ideal for ladder access roof hatches located in stairwells or closets.

Also offered in sizes for staircase access and special sizes are available for unique access requirements.

To learn more, visit www.bilco.com or call 800.366.6530



The Worldwide Source for Specialty Access Products



Figure 11 – ETFE roof spanning the playing field.

Figure 12 – A blend of synthetic and natural turf.



time, coordination efforts increase dramatically as construction gets underway, resulting in requests for information (RFIs) and change orders that could have been avoided.

Once the coordination of the ETFE system is as complete as possible, it is recommended that on-site visual and performance standalone mock-ups be constructed that incorporate the interface conditions (already-completed laboratory mock-ups may suffice). These mock-ups help to further define coordination and sequencing issues, as this often-unfamiliar system is tied together with more typical systems. On-site mock-ups should include the exact materials that will be installed in the field, and should be installed by the same subcontractor personnel who will be working on the project. Performance testing should also be completed at this stage, primarily focused on air leakage and water penetration. To better permit testing and detailed visual review, standalone mock-ups are recommended instead of in-situ mock-ups, as access is usually very limited in the locations ETFE systems are installed.

Lastly, it is highly recommended that a careful quality control (QC) program be implemented by the design-build contractor and the third-party enclosure consultant while the ETFE assembly is installed. Well-implemented and understood QC programs have been shown to have substantial positive impacts on workmanship quality.



CASE STUDIES

Forsyth Barr Stadium

Known locally as the “Glass House,” the giant roof of the Forsyth Barr Stadium in Dunedin, New Zealand, is the world’s first stadium with a nonoperable roof to boast a stationary blended natural and synthetic turf (Figure 11). This is only possible due to the high transparency of ETFE in all light wavelengths used for photosynthesis. A total of 220,660 sq. ft. of transparent ETFE cover the field area. Supporting the nearly 300 double-layered cushions are five external arch trusses that span 345 ft. from the tops of stadium seats. Though the roof system has an internal clearance of 121 ft. and a maximum height of 154 ft., its light weight makes it possible to be supported by only 33-ft.-tall external arch trusses. Between each of the arches is a series of flat trusses that support four long, inflated ETFE cushions. Although the turf is buffered with a synthetic component to assist with the heavy impact traffic, it is still highly sought after for its natural feel and play (Figure 12).

ETFE: Vector Foiltec

Architect: Populous - Jasmax

Owner: Carisbrook Stadium Trust

Engineer: Grayson Engineering Ltd.

General Contractor: Hawkins Construction

Completion Date: 2011

Center Parcs

Center Parcs, in Vienne, France, is a waterpark that is open to the public all year long, thanks to its ETFE roof (Figure 13). The ETFE roof covers 63,000 sq. ft., with three-foil ETFE cushions. This project emphasizes the unparalleled design flexibility with its unique shapes and artistic form (Figures 14 and 15). Additionally, the occupants, including the plant life, are treated to the full spectrum of needed light with the ETFE being permeable to both natural light and UV rays (Figure 16).



Figure 13 – Indoor aquatic park. Photo by Birdair.



Figure 16 – ETFE roof system from interior. Photo by Birdair.



Figure 15 – Installation of ETFE cushion. Photo by Birdair.

U.S. Bank Stadium

The new U.S. Bank Stadium in Minneapolis, Minnesota, is one of the first major sporting venues in the United States to incorporate ETFE (Figure 17). The roof

of the new home for the NFL's Minnesota Vikings is fixed, but 60% of it was constructed using 240,000 sq. ft. of ETFE. The ETFE roof is comprised of 75 cushions, the longest measuring over 300 ft. in length (Figures 18 and 19). To date, U.S. Bank Stadium is the largest

ETFE installation in North America and is the only stadium in the nation with a clear ETFE roof. However, the decision was still made to proceed with an artificial field turf instead of a natural one, due to the multiple event venues that the stadium will host.

Because of the slopes of the roof, ETFE

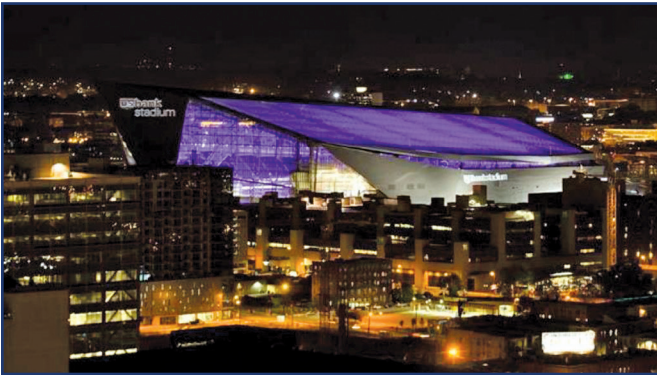

Figure 17 – Stadium at night with interior lighting coloring the ETFE and curtainwall assemblies. Photo by www.Vikings.com

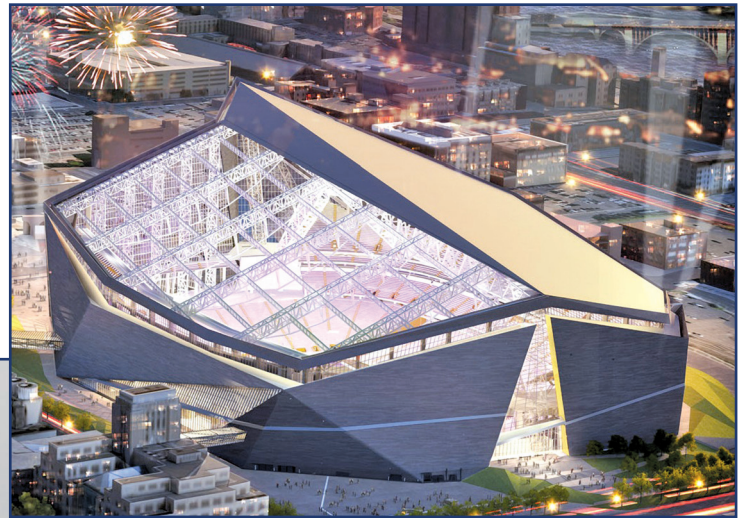

Figure 18 – View of ETFE roof system (left) and single-ply membrane (right).



Figure 19 – Installation of ETFE cushions.

material on the south side makes up 60% of the entire roof, while a traditional single-ply roof over metal decking accounts for the remaining 40% on the north side where the solar exposure benefits are reduced (Figure 20). Though the ETFE doesn't cover the entire field, the angle of the roof allows sunlight over its entirety (Figure 21). Even on a cloudy day, the interior of the stadium is well lit without the assistance of artificial lighting. Rain and snow are managed with a sloped roof strategy that empties into a large snow gutter system encircling the building. In the case of snow, this gutter has an ice/snow melt system that will melt and drain it away. Having already been in place through one winter season while under construction, the ETFE roof was observed to shed snow better than the single-ply membrane roof on the opposing slope.



Figure 20 – Installation of ETFE cushions.

ETFE: Vector Foiltec
Architect: HKS
Owner: Minnesota Sports Authority
Owners Rep: Hammes Co.

Engineer: Thornton Tomasetti
General Contractor: Mortenson – Thor JV
Completion Date: 2016

Mercedes Benz Stadium
 The NFL Atlanta Falcons will enjoy ETFE accents on their new \$1.8 billion stadium, slated for completion in 2017

Introducing the *RCI Interface* Gift Subscription

- Demonstrate to your clients the value of working with you — an RCI member.
- Show your commitment to education and integrity with a gifted subscription to *RCI Interface*, technical journal.



RCI members can now give clients or colleagues an *RCI Interface* Gift Subscription for only \$35 a year (U.S. only).

The recipient's first issue will be accompanied by a letter detailing the benefactor of the gift subscription.

At the end of the year, the subscriber will be contacted to become a member or to renew the subscription at the regular annual subscription rate.

RCI, Inc. 800.828.1902 rci-online.org

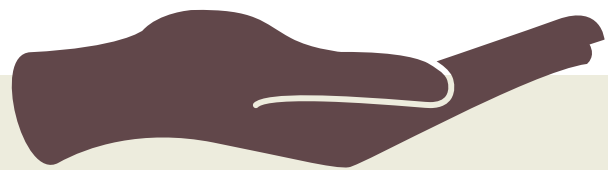

Give the Gift of *RCI Interface* today!

To purchase, login to your Member Account and search the Online Store for *RCI Gift Subscription*.



Figure 22 – Rendering of the Mercedes Benz Stadium showing ETFE roof system and ETFE cladding system. Photo by HOK.

(Figures 22 and 23). The stadium’s operable roof consists of three-layered ETFE cushions on eight “petals” that retract radially, similar to a camera’s aperture diaphragm. Additionally, the façade will feature a single-foil ETFE skin supported by a cable net system. The design requires approximately 135,000 sq. ft. of triple-layered ETFE pillows with an air inflation system for the roof, and approximately 165,000 sq. ft. of vertical, single-layered ETFE film and cable net for the vertical portion. Even when closed, the combination of the ETFE roof and wall areas will create an outdoor feel, allowing in natural sunlight when the weather is clear, and protecting players and fans during inclement weather.

In addition to the transparency benefits, ETFE was a good match for the operable mechanisms employed in the center portion of the roof as opposed to a glazed assembly. It became clear during the design process that the stresses of operational movement posed a risk of broken glazed units and negative impacts on the seals if

the team went with a traditional glazed system. With the lightweight and flexible nature of the ETFE petals, the Atlanta Falcons’ operable roof is expected to be an engineering marvel.

- ETFE:** Birdair
- Architect:** HOK & tvsdesign
- Owner:** AMB Sports & Entertainment
- Owners Rep:** Darden and Company
- Engineer:** Buro Happold
- General Contractor:** Holder/Hunt/Russell/Moody – a joint venture
- Completion Date:** 2017

Detroit Entertainment and Event Center

The main roof area of the new Detroit Entertainment and Event Center, home to the NHL’s Red Wings, and currently under



Figure 23 – Current construction of stadium. Photo by www.11Alive.com.

construction (Figure 24), will be built using traditional low-sloped roof assemblies. The street-like walkway between the arena and surrounding structures, however, referred to as the “Via,” will be covered with a three-foil ETFE cushion system (Figure 25). This lightweight and translucent structure will provide a cost-effective and aesthetically pleasing enclosure for a space that is designed to feel like an outdoor street year-round. Even as visitors enter from the exterior and through the perimeter building into the Via, they will be able to look up and see the impressive arena rising overhead while in the comfort of an indoor environment.

ETFE: Vector Foiltec
Architect: HOK
Owner: The District Detroit
Owners Rep: Hines
Engineer: Magnusson Klemencic Associates
General Contractor: Barton Malow – Hunt – White JV
Completion Date: 2017



Figure 24 – Rendering of the Detroit Entertainment and Event Center. Photo by the District Detroit/HOK.

Figure 25 – Current construction of arena and surrounding structures.



CONCLUSION

ETFE has made an impressive impact around the world and recently in the North American building community, and with some of the pinnacle structures of this generation being crowned by the unique material, its popularity is sure to grow. The attributes of being lightweight, durable, and transparent set ETFE apart from other industry-standard materials and assemblies. Add to that the aesthetic factor of providing a near invisible separation from the exterior, letting in almost uninhibited natural light, and ETFE becomes a very attractive solution.

As with all systems, there remain potential risks. The potential for condensation under certain interior conditioning loads in northern climates needs to be carefully analyzed and addressed to minimize risk. Interfaces with surrounding materials and systems must be carefully designed and diligently coordinated during construction to ensure total enclosure performance. The unique characteristics of this material and the assemblies in which it is used are a clear example of the importance of employing a holistic process of design, construc-

tion, and performance testing to ensure success. 



Lee Durston

Lee Durston is a senior building science consultant with Morrison Hershfield's St. Paul, Minnesota, office with over 16 years of building science experience. He holds a BS in microbiology from North Park University and is a member of the National Institute of Building Sciences and the Air Barrier Association of America. Durston holds a certification in Building Science Thermography (CBST). His current work includes many prominent ETFE installations, including the largest installation of ETFE in North America.



Shawn Robinson

Shawn Robinson, a department manager and senior building science consultant at Morrison Hershfield's Atlanta office, has over ten years' experience with a variety of project types, including sporting venues, high-rise, military/government, higher education, data centers, hospitality, and medical facilities. Robinson's experience includes project management, building envelope design, field review assignments, and condition assessments. Robinson recently received certification as a Building Envelope Commissioning Process Provider (BECxP).

Overtime Wage Increase Fought

The U.S. House of Representatives voted September 29 to stall the Labor Department's overtime rule that would increase wages for an estimated 4.2 million Americans, set to take effect December 1. The House vote comes on the heels of a lawsuit by 21 states against the Obama administration, claiming the overtime rule would place a heavy burden on state budgets and force layoffs. The Associated Builders and Contractors (ABC), along with a coalition of other groups, also filed a federal lawsuit seeking to overturn the rule.

Labor Secretary Thomas Perez has claimed the legal challenges are attempts to deprive workers of fair pay. "The same interests that have stood in the way of middle-class Americans getting paid when they work extra are continuing their obstructionist tactics," he told *Bloomberg*. President Barack Obama has said he would veto the measure, which passed the House 246 to 177, if it was presented to him.

Overtime protections require employers to pay one-and-a-half times an employee's regular rate of pay for any work past 40 hours a week. The final rule raises the salary threshold for overtime eligibility from \$455 per week (\$23,660 per year) to \$913 per week (\$47,476 per year). The new rule also updates the total annual compensation level above which workers are ineligible for overtime from the current level of \$100,000 per year to \$134,004 per year. The salary thresholds will automatically update every three years under the new rule.