

# ON THE EDGE: Sheet Metal Edge Flashings

By Karl Schaack, RRC, PE

Sheet metal flashings installed along perimeters of roofs typically include metal edge/gravel guards, fascias, coping caps, and gutters. The proper design, fabrication, and installation of the components can be critical to successful performance of an overall roof system in both low-sloped and steep-sloped applications. The purpose of this article is to review various conditions and details that have been observed on various projects by the author and to provide optional ideas to enhance or provide improvement to installations.

## METAL EDGE FLASHINGS

This type of fabrication has historically been referred to as a “gravel guard” or “gravel stop,” based on use in aggregate-surfaced, built-up roof assemblies. It often features a knuckle (or “kick”) at the top edge of the fascia to provide a dam or guard to prevent bitumen running over the face and to retain aggregate on the roof. The Sheet Metal and Air Conditioning Contractors National Association (SMACNA) long ago defined the recommended guidelines for dimensions and the securement of this type of fabrication. The horizontal nailing flange has traditionally been 4 in. wide and secured with fasteners (nails) spaced 3 in. on center (o.c.) and staggered, positioned  $\frac{3}{4}$  in. from the knuckle and 1 in. from the edge of the flange (Figure 1).<sup>1</sup>

The joints of adjoining sections of the metal edge flashing can be formed by either overlapping the sections (minimum 4 in.) or by butting adjacent sections with a  $\frac{1}{4}$ -in. gap between butt ends, and then installing either backup or cover plates positioned at butt joints. Cover plates would be secured

with fasteners positioned through the butt joint between adjoining sections of metal edge.

The author has experienced instances in which sheet metal fabricators crimp the outer edges of sheet metal used to form cover plates prior to forming the shape so

that the cover plate will conform or lay flat on the fascia. But these crimps also extend to the flange of the metal edge and protrude upward. Subsequently, installers will commonly place nails alongside of cover plates with the nail head overlapping onto the cover plate to hold it down (Figure 2).

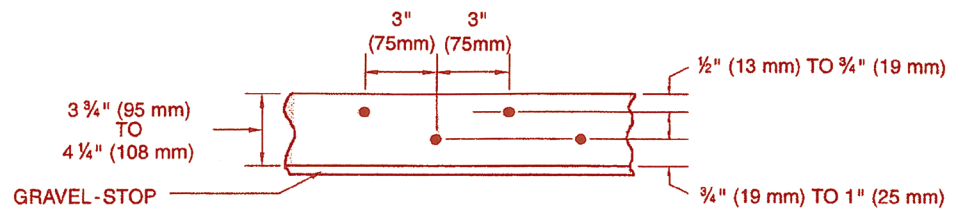

BASIC FLANGE NAILING PATTERN

Figure 1 – Basic flange nailing pattern.

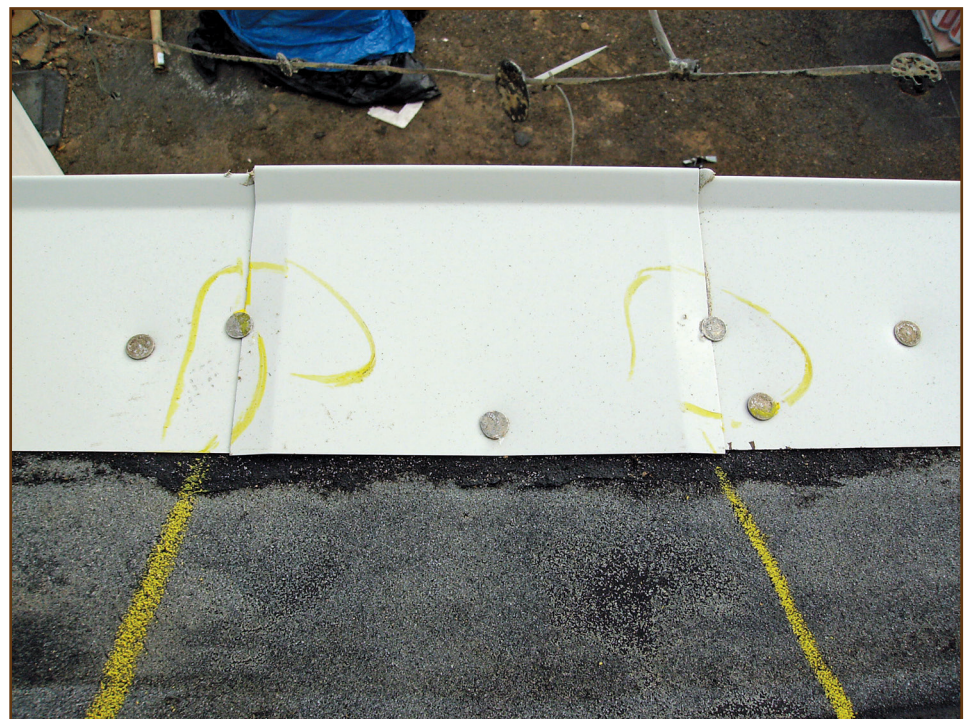
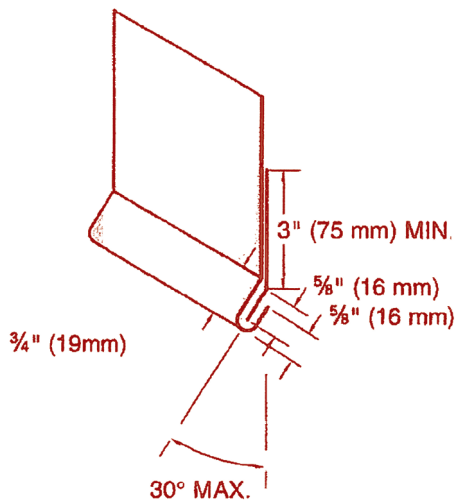

Figure 2 – Nails installed at sides of cover plate.



**DETAIL 1**

**Figure 3 – Cleats are secured as low as possible on the vertical leg.**

Consequently, the placement of these nails would restrict differential and thermal movement that would be anticipated between adjoining sections of metal edge flashings and cover plates. SMACNA recommends corrosion-resistant nails with a barbed shank. The author recommends the use of either stainless steel or double hot-dipped galvanized ring-shank nails with a minimum 3/8-in. diameter head and long enough to achieve a minimum 1 1/4-in. embedment into underlying wood nailers. Pre-drilling nail holes in the horizontal flange of metal edge flashings not only allows for installation of nails without dimpling the flange but also provides an installer with a predetermined spacing, eliminating the need for field measuring, and reducing possible inaccuracies.

The knuckle height of a metal edge for gravel-surfaced built-up roofs will vary slightly compared to modified-bitumen roof



**Figure 4 – Metal edge, strip-in, and cap sheet.**

assemblies. This height can be an important factor, particularly if the roof is sloped toward the perimeter and drainage is directed over the edge. Metal edges with traditional knuckle heights installed on drainage edges for modified-bitumen roofs will be too tall and result in ponding water along the roof edge.

For bituminous built-up roof systems, the nailing flange has traditionally been set in a bed of plastic roof cement on top of the membrane. An asphaltic primer is typically applied to the bottom surface of the flange prior to embedding the flange into cement. This practice has also translated over into installations of metal edge systems on modified-bitumen roof systems. While plastic cement is suitable for styrene butadiene styrene (SBS) modified-bitumen materials, some types of these cements can be detrimental to atactic polypropylene (APP) materials due to somewhat higher solvent content. Consequently, APP sheets can be softened with a handheld torch or hot-



**Figure 6 – Tooling sealant.**

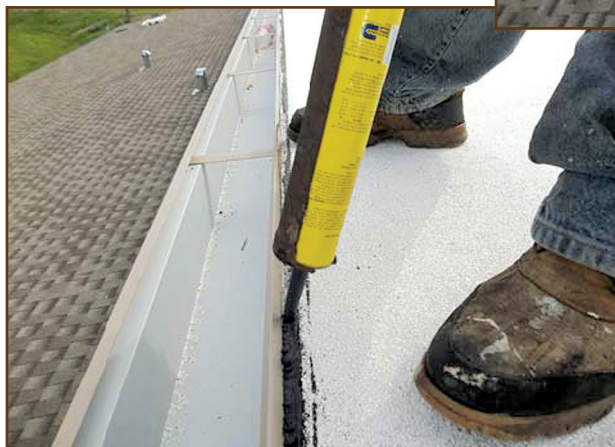

**Figure 5 – Applying edge sealant.**



**Figure 7 – Granules embedded in sealant.**

air gun prior to placement of primed metal edges.

Cleats depicted in the SMACNA manual are fabricated with drip edges at specified angles and then secured as low as possible on the vertical leg (Figure 3).

Contractors commonly fabricate cleats with a horizontal leg at the top edge so that this flange can be placed on the roof surface for ease of maintaining a constant level or straight line of the cleat without requiring the need to field-position each individual section along a placed chalk line. Often, installers will secure the cleat with nails placed in this horizontal leg and not place additional fasteners in the vertical leg, consequently reducing wind uplift resistance of the fabrication.

On bituminous roof assemblies, strip-ping in horizontal nailing flanges is accomplished with felt plies (commonly two) or modified-bitumen sheets. Again, asphaltic primer is applied on the top surface of the flange to receive strip-in. Abrading or roughing up the top surface of prefinished sheet metal to provide a suitable surface in order to apply primer is a common practice and recommendation in order to achieve an optimum bond. Some manufacturers recommend placing the metal edge on top of a granule-surfaced cap sheet and then applying strip-in. However, for a draining edge, this method of strip-in would result in a lap seam that bucks water.

The author feels that metal edge flashings should be installed on top of the smooth-surfaced base ply, stripped in with another layer of smooth-surfaced base ply, and then the cap sheet should be installed (Figure 4). Installing the cap sheet in a picture-frame fashion results in fewer laps in the cap sheet occurring along the perimeter, which is advantageous along a draining edge.

After the cap sheet is applied along the metal edge, the author recommends the application of a modified-bitumen-based or elastomeric plastic roof cement along the cap sheet termination and knuckle to fill in this space. Granules could then be embedded into the edge sealant to provide ultraviolet (UV) protection and create monolithic surface color (Figures 5, 6, and 7). This type of material is commonly available in tubes so that it can be readily gunned into the subject space and tooled flush with the top of the cap sheet.

The author has seen the use of polyurethane sealant for this purpose; however, this type of sealant is not compatible with bituminous-based materials and will readily develop bituminous stains and become disbonded (Figure 8).

**Figure 8 – Urethane sealant disbonded along edge of cap sheet.**



# Bil-Guard® 2.0

## Hatch Safety Railing System



*Bil-Guard 2.0 shown on Type S-20 3'0" x 2'6" roof hatch*

**Stronger. Simpler. Better.**

Now Featuring Corrosion-Resistant Aluminum Rails

### Product Features

- Meets and exceeds OSHA 29 CFR 1910.23
- Non-penetrating attachments; quick and simple installation with standard tools
- Corrosion-resistant aluminum rails and mounting brackets, along with stainless steel hardware, are ideal for any climate
- Safety yellow powder coat paint finish
- Self-closing and locking gate
- Fits all brands of roof hatches with capflashing
- Available in standard and custom sizes



Stainless steel spring hinges and self-closing gate



Automatic gate latch with interior and exterior release patent pending



Pivoting post mounting brackets



For more information, call (800) 366-6530 or visit [www.bilco.com](http://www.bilco.com)

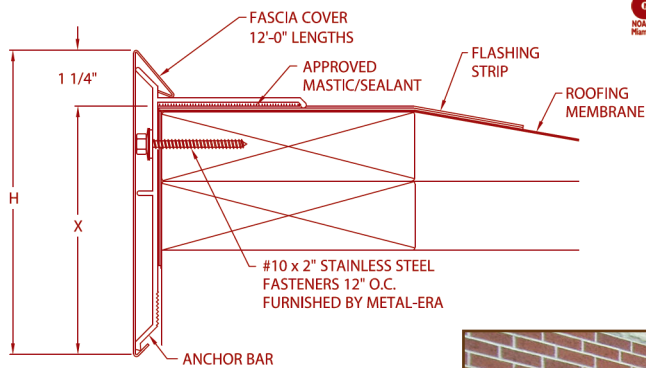

**Figure 9 – Water under single-ply strip-in at edge of cover plate.**

Polyether sealants have been reported to provide better bond and compatibility with bituminous products and may prove to be suitable for this type of application. Without the use of edge sealant, a void or trough will typically be present between the edge of the cap sheet and the knuckle of the metal edge, which can allow water to collect. Embedded granules will provide weathering protection for the edge sealant material. Cracks have commonly been observed in bleed-out (mopping asphalt or exuded molten modified bitumen) at this location after weathering. These cracks or fissures may extend under the cap sheet and provide avenues for moisture migration.

Installation of metal edge flashings for single-ply membrane roof systems is somewhat different in that the fasteners are typically specified by manufacturers to be spaced 4 in. o.c. and positioned on the flange so that a 1½-in.-wide welded or bond surface beyond the fasteners can be achieved with a strip-in membrane. Recently, self-adhering single-ply tapes have been used as strip-in flashing of

flanges of metal edge flashings. The author has found that this type of strip-in flashing membrane achieves a better bond over horizontal flanges of metal edges when back-up plates are used at butt joints compared to cover plates. If sealant is placed on top of the back-up plate to fill in the butt joint, a uniform substrate is created for bonding the self-adhering sheet. Cover plates installed over butt joints result in an uneven substrate due to the overlapping layers of sheet metal that can cause bridging of the self-adhering sheet over the edges of cover plates, creating small voids that can allow water entry (Figure 9).



**Figure 10 – Detail of termination or anchor bar set in sealant with prefinished sheet metal fascia snapped onto the bar.**



**Figure 11 – Biological growth on brick from leakage at joint in metal edge.**

Even if a hand-held roller is used during TPO or PVC application, achieving an adequate bond of strip-in at this location is very difficult due to the relative rigidity of the strip-in material. The author prefers using membrane-clad sheet metal to form fabrications to receive strip-in flashing so that strip-in membrane can be hot-air welded to the metal flange. The author recommends the application of cut-edge sealant along the outer edge of the strip-in membrane to conceal any possible minute voids or openings that may be present, particularly at overlaps in the strip-in flashing.

**PRE-ENGINEERED/  
MANUFACTURED ASSEMBLIES**

Many prefabricated/pre-engineered metal edge systems offered by manufacturers are comprised of an extruded aluminum termination/retainer bar that is installed on top of single-ply membranes and extends over the roof edge. This extrusion is commonly secured to the substrate with fasteners installed through



**Figure 12 – Deteriorated sealant at joint in metal.**

the vertical face. The termination bar is typically set in sealant on top of the single-ply membrane, and then a prefinished sheet metal fascia is snapped onto the bar (Figure 10).<sup>2</sup>

While this type of system may provide

a suitable anchorage for roof-edge flashing, the author has observed on many occasions that water can migrate under the T-bar on top of the membrane and down the exterior face of the building. Although this may not result in direct water infiltration into the



**WE TAKE THE FIRST STEP  
SO YOU DON'T TAKE YOUR LAST**



Each unit features patented GrabSafe™ handholds, providing 3-point control throughout egress and ingress. Guardrail extensions create a landing area to ensure safe operation of the self-closing gate while standing on the walking surface, not the ladder.

Designed to meet and exceed OSHA, Cal-OSHA, ANSI/ASSE and USACE standards

**ROOF HATCH GUARDRAIL**  
THE SAFEST WAY TO USE A  
ROOF HATCH

**WWW.LEADINGEDGESAFETY.NET**



**PRS**  
PREMIER RAIL SYSTEMS

**Figure 13 – Detail of prefinished sheet metal fascia snapped onto fabrication.**

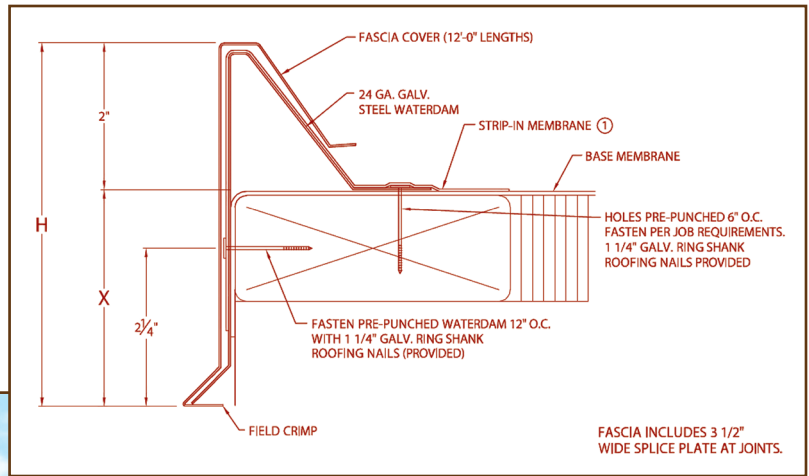

**Figure 14 – Metal snap-on fascia not engaged to cleat.**



building, staining and biological growth can occur on the exterior building finishes where water repeatedly drips (Figures 11 and 12).

The author has found that a common fabrication comprised of a canted cleat or “water-dam” profile installed over the membrane and secured on both the horizontal surface and vertical face provides a more desirable solution with similar wind-resistance performance but does not allow water migration down the building face. The strip-in flashing is extended from the roof membrane up and over the cant/water dam and down (and adhered to) the vertical face of the profile. A prefinished sheet metal fascia is then snapped onto the fabrication (Figure 13).<sup>2</sup>

## Publish in RCI Interface

RCI Interface journal is seeking submissions for the following issues. Optimum article size is 2000 to 3000 words, containing five to ten graphics. Articles may serve commercial interests but should not promote specific products. Articles on subjects that do not fit any given theme may be submitted at any time.



ISSUE	SUBJECT	SUBMISSION DEADLINE
March 2017	Trends in wall & roof design	December 15, 2016
April 2017	Air and vapor control	January 13, 2017
May/June 2017	Convention review	February 15, 2017
July 2017	Testing	April 14, 2017
August 2017	Health and safety	May 15, 2017
September 2017	Building envelope (Misc.)	June 15, 2017

Submit articles or questions to Executive Editor Kristen Ammerman at 800-828-1902 or [kammerman@rci-online.org](mailto:kammerman@rci-online.org).



**Figure 15 – Fascia of coping not engaged to cleat.**

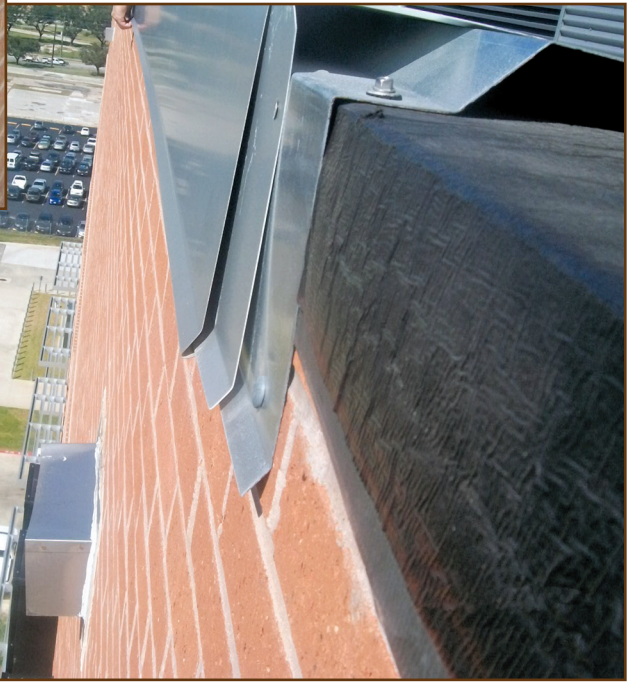

**Figure 16 – Drive pin installed in face of cleat.**

Code-enforced ANSI/SPRI ES-1 and the premanufactured tested assemblies currently on the market have improved the overall performance of metal edge flashings, particularly in high-wind zones. The commentary contained herein is not intended to be an indictment of these systems, but rather to note that some of the assemblies may have certain nuances associated with installations that could have unintended consequences.

The installation tolerances for many of these premanufactured fabrications are determined by the actual dimensions of the factory-formed sheet metal fabrications compared to existing or as-built dimensions of a building wall. Variations in building walls along lengths of installed predetermined-sized sheet metal can result in atypical placement of fasteners and clips that may not allow for adequate attachment of snap-on copings or fascias as compared to original systems tested in laboratory settings and uniformly fabricated during manufacturing processes. While installers are responsible for providing accurate dimensions to these manufacturers and achieving a proper installation, subtle variations in construction conditions may result in what may be considered substandard installations that don't meet the intent of original designs of tested assemblies (*Figure 14*).

The author has observed many instances where a snapped-on cap flashing could be readily snapped off by hand due to the cleat and cap flashing not integrating properly, as well as situations where gaps were observed when a cleat and coping assembly extended out beyond the actual width of a wall. In another instance, sections of premanufactured coping had become displaced from the top of a parapet wall during very low wind speeds. In this particular case, drive-pin fasteners had been positioned by the installer on the vertical face of the cleat and installed



**Figure 17 – Typical cleat/chair for coping.**



**Figure 18 – Metal edge flashing for steep-slope roof with 1½ -in. flange.**



**Figure 19 – Fasteners for rake flashing installed in joint between fascia cement boards.**

into a masonry substrate as an apparent attempt to have the fascia of the coping conform closer to the exterior face of the masonry. This condition caused the outer face of the cleat to be pulled tighter to the face of the building (reducing overall width of cleat) and did not allow proper or full engagement of the bottom edge of the outer fascia of the snapped-on coping (Figures 15 and 16).

Another common premanufactured system used intermittent cleats/chairs in a coping assembly that were positioned at butt joints and a mid-span of the coping segment. These chairs are commonly fabricated on an angle to create slope in the top surface of the coping. In addition, the

chairs are commonly secured to a flat/level substrate with fasteners penetrating down through the top of a parapet wall and through the underlayment applied over the horizontal substrate (Figure 17).

While the author does not have actual supporting evidence of the detrimental effects of this type of installation, installing a coping over a sloped continuous solid substrate with a suitable underlayment

and fasteners installed in vertical faces for attachment purposes intuitively lends itself to better long-term performance and fewer risks. Additionally, many manufacturers offer this type of assembly in a premanufactured option that can comply with ES-1 criteria.

#### STEEP-SLOPED APPLICATIONS

Although considered somewhat incidental or less important, the attachment of metal drip edges at low eaves or rake edges on shingle roofs is often not performed to industry standards. NRCA and ARMA recommend securing horizontal flanges of these fabrications to substrates with fasteners placed 6 to 8 in. on o.c. and enhanced in high-wind zones.

The author has witnessed this type of installation anchored in a wide variety of spacings, from 12 to 24 in. o.c. Some installers reportedly place just a few fasteners in the flange—basically to hold it in place until the felt underlayment is installed. Then cap nails are installed to secure the underlayment, positioned close to the edge of the roof in order to engage the flange of

**RCI has expanded its online presence!**

You probably already know about our new website at [rci-online.org](http://rci-online.org), but did you know we're also on:



Facebook at [facebook.com/RCIonline](https://facebook.com/RCIonline),



Twitter @RCI\_Inc, and



our LinkedIn page at [linkedin.com/company/rci-inc](https://linkedin.com/company/rci-inc).

**DON'T FORGET THE PERIOD!**

the drip edge and provide additional securement. Others attempt to secure the metal drip edge with nails into the starter courses of shingles along the eaves. However, the flanges of drip edges that are commonly available from roofing material suppliers are only 1½ to 2 in. wide (Figure 18); therefore, it is difficult for the intended supplemental fasteners to hit their mark and properly engage the nailing flange.

Another issue that has been observed with commercially available drip edges with narrow flanges is achieving proper securement when fascia boards are installed along the roof edge. Fascia boards are commonly ¾-in. thick and can consist of stair-



**Figure 20** – Gutter spacer fastened into face of drip edge; also note no visible fasteners in flange of drip edge.

## Introducing the *RCI Interface* Gift Subscription

- Demonstrate to your clients the value of working with you — an RCI member.
- Show your commitment to education and integrity with a gifted subscription to *RCI Interface*, technical journal.



RCI members can now give clients or colleagues an *RCI Interface* Gift Subscription for only \$35 a year (U.S. only).

The recipient's first issue will be accompanied by a letter detailing the benefactor of the gift subscription.

At the end of the year, the subscriber will be contacted to become a member or to renew the subscription at the regular annual subscription rate.

RCI, Inc. 800.828.1902 [rci-online.org](http://rci-online.org)

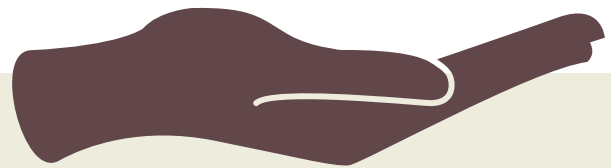

**Give the Gift of *RCI Interface* today!**

To purchase, login to your Member Account and search the Online Store for *RCI Gift Subscription*.

stepped double layers (large board and smaller board). Fasteners that are used to secure the flanges of these drip edges are positioned and installed in the joint between the fascia board and deck or will often split the fascia board, resulting in inadequate attachment. Additionally, if the fascia board is comprised of fiber-cement material commonly found in current construction, roofing nails will not penetrate into the fiber-cement board nor achieve proper embedment (Figure 19).

Another common installation issue observed in steep-slope shingle roofs is coordination between the shingle and gutter installations. Quite often during new construction, the shingles are installed by one contractor, and the gutters (quite often roll-formed on site) are installed by a different contractor. Shingles are installed and completed, and then gutters are installed. The roll-formed gutters typically do not have a tall enough vertical flange to extend behind the fascia of a drip edge, and gutters are installed on top of the fascia with screws penetrating through the drip edge fascia and

typically into an underlying fascia board (Figure 20). This can result in two problems: 1) water can migrate behind the gutter and down the fascia board, staining building finishes, and 2) inadequate anchorage of the gutter may occur if underlying fascia board is against a fiber-cement material.

Although these observations are related to residential roofing, this type of work has also been observed on large-scale, multi-family, multistory projects where quality installation of sheet metal edge flashings is a critical component—particularly in high-wind zones.

In summary, not only do perimeter edge metal flashings provide the first line of defense of a roof system during wind loading, but properly planned, fabricated, and installed sheet metal flashings can make a significant difference in the overall appearance and performance of a completed roof assembly. Utilizing special techniques, installation sequences, or taking additional time during installation of these fabrications can also provide noticeable enhancements. 

## REFERENCES

1. SMACNA *Architectural Sheet Metal Manual*, 2012.
2. Metal Era product catalog.



Karl A. Schaack,  
RRC, PE

*Karl A. Schaack is president of Price Consulting, Inc., located in Houston, Texas. He holds a bachelor's degree in civil engineering from Clemson University and is a registered professional engineer and a Registered Roof Consultant. Schaack has served on numerous RCI committees since joining in 1996. He has authored articles for RCI Interface and other industry publications. In 2007 and 2015, he was awarded RCI's Richard Horowitz Award for excellence in writing for Interface journal.*

# METAL ROOFING GAMES



At METALCON, the largest international event for the metal construction industry, sponsored by the Metal Construction Association (MCA), teams of metal roofing construction experts compete in construction challenges. This year, the Battle Stars over Baltimore was held at Baltimore Convention Center October 26-27. In the two-day competition, five teams with two contestants each competed to split \$5,000.

Each battle took 15 to 30 minutes and required speed and accuracy to win. Contests included:

- A screw gun battle, which required contestants to install 24 self-drilling screws four inches apart into 8-ft.-long steel purlins on an 8- x 8-ft. steel framework platform
- A “Hug-a-Roof” battle, in which contestants installed 40 linear feet of factory-notched, zee-shaped sub-purlins on a mock-up ribbed metal roof paneled frame
- A standing seam battle where the goal was to install a 16-in.-wide metal roof panel over factory-notched sub-purlins
- A “Seam-It-Up” battle, with contestants operating a standing seam roof seamer over 16-in-wide metal roof panel seams
- A “Let It Snow” battle, where contestants installed a mechanically attached snow retention system onto 16-in. metal roof panels

Judging was provided by the Metal Building Contractors and Erectors Association (MBCEA).

