

“Value-Engineered” Waterproofing Errors

By Lonnie Haughton, MCP, LEED AP, CDT

INTRODUCTION

In theory, “value engineering” should embody a multidisciplinary application of technical knowledge, specialized expertise, and common sense directed at identifying and eliminating unnecessary construction costs while still maintaining (or improving) the value, quality, and functionality originally intended by the designer.

In practice, strong desires to reduce construction costs can pit contractors and owners against architects and engineers who may not have sufficient time (or practical construction expertise) to fully assess all technical ramifications of a particular value-engineered proposal. Even so, ensuring performance failures can enmesh the builder and designer in a lawsuit by an aggrieved owner who blames them jointly for the resulting damage.

poorly conceived and/or insufficiently vetted value engineering proposal that was overly focused on cost-cutting to the long-term detriment of the project. This case study presents an example of this problem.

THE PROJECT

Consider a 160-unit, three-story, wood-framed residential apartment complex south of San Francisco. The upper apartments are served by the wood-framed elevated walkways seen in *Figure 1*, capped with 1½-in. engineered wood decking, a fluid- and spray-applied waterproofing/flashing system, and a concrete walking surface. The architect’s original design called for the framing to be tapered to the exterior, thereby providing positive slope-to-drain at both the waterproofing layer and at the concrete walking surface, as seen in *Figure 2*.

In the forensic arena of construction defects litigation, it is not uncommon to trace the history of a failed as-built design back to a

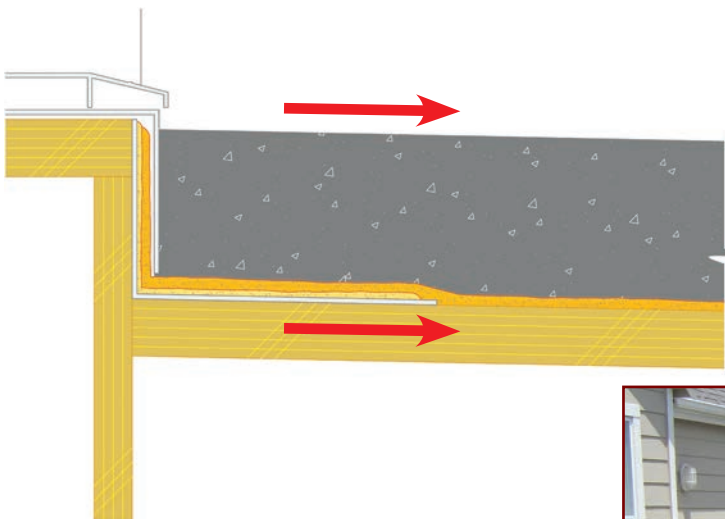

Figure 2 – The architect’s original design called for positively sloped framing, decking, waterproofing, and concrete that served to drain rainwater toward the exterior edges of these elevated walkways. (Litigation exhibit by Andrew D. Trias.)

Figure 1 – Upper-story tenants at this apartment complex are served by 3000 lineal feet of wood-framed elevated walkways.



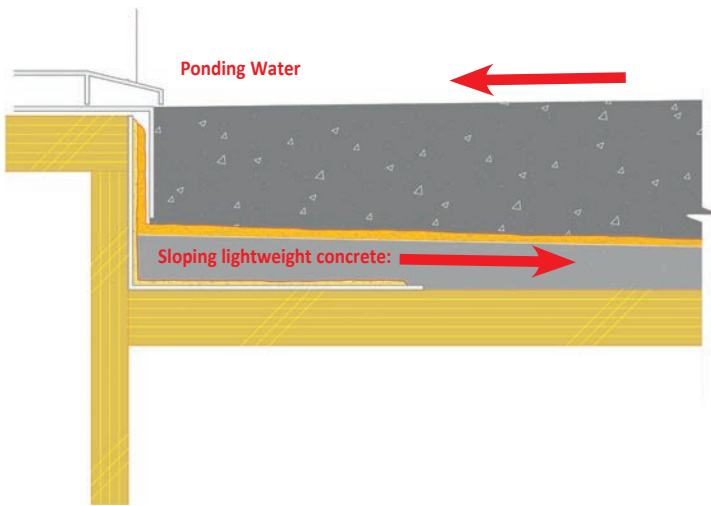

Figure 3 – The as-built proposal instead provided sloping lightweight concrete under the waterproofing membrane. However, this alternate design produced negative slope, ponding water, and locally severe framing damage below the concrete walking pad. (Litigation exhibit by Andrew D. Trias.)

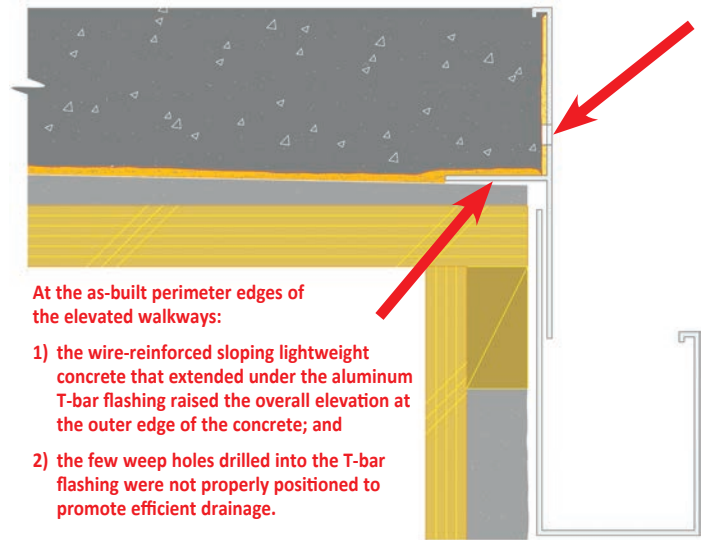

Figure 4 – Sloping lightweight concrete extending under the 2-in. aluminum T-bar flashing at the outer edge served to raise its overall height. Additionally, the relatively few weep holes drilled into this metal flashing were not properly positioned to promote efficient drainage of the waterproofing membrane. (Litigation exhibit by Andrew D. Trias.)



Figure 5 – Elevated walkway posts and beams were manufactured from glue-laminated Alaskan yellow cedar.

**VALUE ENGINEERING PROPOSAL
ACCEPTED BY ALL PARTIES**

As evidenced by Figures 1 and 5, a complex layout of elevated walkways (totaling 3,000 feet long and 19,200 square feet in area) wrapped around the 104 upper-story units at this facility. Clearly, the architect's original plan (per Figure 2: providing positive slope for walkway waterproofing drainage by individually cutting a taper into

Figure 7 – The relatively few weep holes drilled into the T-bar flashing were not properly positioned (see Figure 4) to promote efficient drainage of the waterproofing membrane.



Figure 6 – Maintenance staff had carved out numerous portions of the outer edge of the T-bar flashing and concrete in order to provide drainage relief for areas of particularly problematic ponding.



every one of the supporting wood framing members) would have been laborious and costly.

Instead, the contractor proposed installing a layer of wire-reinforced, sloping lightweight concrete (see *Figures 3 and 4*) under the fluid-applied waterproofing membrane as an alternate method of providing the positive slope sought by the architect. The value-engineered cost savings would be tremendous.

After review, all parties accepted this plan. Further, the architect contracted to provide daily, full-time, on-site inspection to actively monitor and accept all aspects of this elevated walkway waterproofing. (As further reviewed below, this close, day-to-day involvement with the actual construction process eventually proved to be very costly for the architect's insurance carrier.)

FUNDAMENTAL FLAWS IN THE ACCEPTED PROPOSAL

Unfortunately, during the entire course of construction, both the architect and the contractor failed to recognize that due to: a) the additional thickness of the lightweight concrete and b) the additional height that was inherent in not tapering the wood framing per the original plans, the outside elevations of these concrete walkways were being raised significantly in relation to the already-fixed height of the apartment entry doors (compare *Figures 3 and 4*.)

By not taking into account the predetermined elevations of these door thresholds, the architect and contractor allowed the as-built walkways to be negatively sloped toward many of these entry doorways. Later, as seen in *Figures 6 and 7*, the owner's maintenance personnel responded to interior flooding through these poorly crafted thresholds by literally grinding out portions of the outer edge of the metal T-bar flashing and concrete in order to provide drainage relief for areas of particularly troublesome rainwater ponding.

Additionally, note in these two figures (also see *Figure 4*) that the few weep holes that had been drilled (post construction) into the perimeter aluminum T-bar flashing were not properly positioned to promote efficient drainage of the waterproofing membrane; trapped water eventually leaked down through various as-constructed flashing and membrane deficiencies, attacking the heavy glue-laminated wood structural beams and columns below.

ANOTHER MAJOR OVERSIGHT BY THE CONTRACTOR AND THE ARCHITECT'S INSPECTOR

As depicted in *Figure 8*, the polymeric waterproofing membrane was fluid-applied to the top of the lightweight concrete and to the vertical leg of the underlying spray-applied flashing. (Both products had essentially the same two-component synthetic rubber mix.) Unfortunately, even though the architect's original waterproofing details had shown sheetmetal counterflashing at these walkway-to-wall transitions, none was

installed at this gap between the concrete and the fiber-cement lap siding.

Due to this oversight, the spray-applied flashing degraded at multiple locations due to direct exposure to sunlight. As can be seen in *Figure 8*, any rainwater that infiltrated through voids in the vertical flashing membrane eventually could migrate all the way down to the engineered wood decking below, further exacerbating the deterioration and structural decay found at all of the walkways. (As would be expected, the architect's failure to notice that his own counter-



LET'S JOIN FORCES.

Working hard, together.

TRUFAST®

As a commercial roofer, you're no stranger to hard work and demanding schedules. At TRUFAST, we aren't either. That's why our fastening solutions and rooftop accessories come with a hardworking team to back them up. With superior customer service, job site pull tests, five warehouse locations and over 35 sales representatives in North America, you know we're always working hard for you.

When you need commercial roofing products from a single trusted source, think TRUFAST, where our team works alongside yours.

2018 International Roofing Expo

February 6-8

Ernest N. Morial Convention Center | Halls B-D | New Orleans, LA

Trufast Booth No. 1217

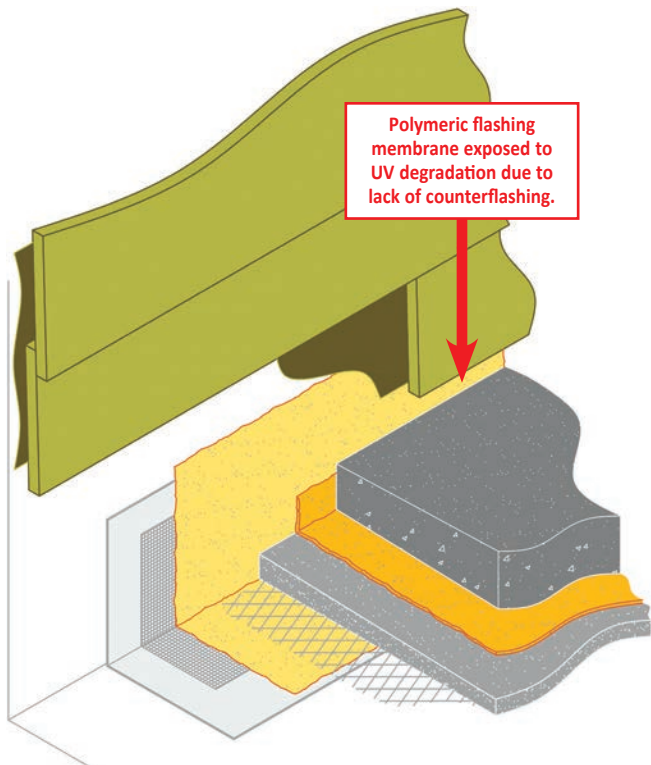

Figure 8 – In lieu of tapered wood framing, the as-built design provided sloping wire-reinforced lightweight concrete under the fluid-applied waterproofing membrane. Additionally, note that UV-resistant counterflashing was not installed to protect the exposed spray-applied flashing membrane from direct sunlight. (Litigation exhibit by Andrew D. Trias.)

flashing had not been installed was highlighted by several of the parties enmeshed in the ensuing litigation.)

DOES THE VALUE ENGINEERING PROCESS INHERENTLY INCREASE THE PROPENSITY FOR SIMILAR ERRORS?

In our experience, the general propensities for construction errors and oversights appear to increase whenever complex value-engineered redesigns are implemented. We speculate that the bright, rosy aura emanating from envisioned cost savings can distract initial reviewers from making the deep technical evaluations necessary to identify all unintended ramifications of the new plan. Later, during the course of the construction, inspectors' deference to the judgment of the originator (often, the contractor) of the alternate design may lead them to miss early warning signs that might otherwise be obvious.

To guard against such potential tendencies, prudent owners should consider investing a portion of the projected costs savings into added layers of technical inspection and evaluation that

would serve as a form of insurance against glitches in the construction process.

While such investments in what could be called "value-engineering insurance" of course would not prevent all future errors, they could add an additional pot of money to help fund necessary major repairs. At this project, while the added oversight contracted from the architect did not protect these wood-framed elevated walkways from widespread structural decay, the architect's insurance policy (and others) did help to ensure full funding for the post-litigation reconstruction. 



Lonnie Haughton, MCP, LEED AP, CDT

Lonnie Haughton, MCP, LEED AP, CDT, is a principal codes consultant with Richard Avelar & Associates in Oakland, CA. He is a licensed general contractor and one of about 800 individuals nationwide who are certified by the International Code

Council as active Master Code Professionals. Haughton's many additional ICC certifications include California Building Inspector, Building Plans Examiner, and Certified Building Code Official.

American Wood Council Notes NDS Changes to Nail Withdrawal Testing

The National Design Specification for Wood Construction (NDS®), published by the American Wood Council, has made changes with respect to the withdrawal (pullout) values of nails in wood and wood products. The International Staple, Nail, and Tool Association (ISANTA) has published an advisory on the changes. In the 2018 edition, there were five areas of change with regards to nail withdrawal:

- Terminology
- Added design values for Roof Sheathing Ring Shank nails, which were added to ASTM F1667 in 2015
- A clarification to the Post Frame Ring Shank nail withdrawal values
- A clarification in the design values for carbon steel nails
- Addition of design values for stainless steel nails



Ring shank roofing nail. Courtesy of Maze Nails.

To learn more about the particulars of the changes, visit bit.ly/2D4t85t. A presentation on the changes may also be found at: <https://www.youtube.com/watch?v=8jH5Qpgw1YA>.