



APPLICATION FOR REGISTERED ROOF OBSERVER (RRO®)

Dear RRO Applicant:

To become a Registered Roof Observer (RRO), applicants must meet specific requirements. These requirements include verifiable levels of work experience and education; high ethical standards; and a satisfactory score on an online examination.

The scope of work under this task includes your personal observations during roof construction for the assurance of the quality of work performed by another individual. In most cases, the person who performs these services would be under the direction or control of a superior, a roof consultant, an experienced roof observer, and others. In some cases, the roof observer may provide these services directly. Applicants should submit only work experiences done personally, not by a technician under the supervision of the applicant.

All applicants are encouraged to use the online interactive process to complete this application. However, applications are accepted in this traditional form. Once the application has been submitted to the International Institute of Building Enclosure Consultants (IIBEC) (email or mail is acceptable for delivery), all required information must be provided within one year or the application will expire.

The application fee is \$375 for IIBEC members and \$475 for nonmembers. Please allow 90 days for application processing. Applications will be processed within 60 days for an additional expediting fee (\$50 for members and \$100 for nonmembers),

An exam registration form will be provided after the completed application has been returned to IIBEC and approved. Once you register for the online exam, your information will be submitted to Meazure Learning, the computer-based testing company. The approved candidate will then be contacted by Meazure Learning to schedule a testing session at one of the 1,000 conveniently located testing centers.

Consult <https://www.assessments.meazurelearning.com/test-site-cities/> for the location of the testing center near you. The online exam fee is \$275 for IIBEC members and \$375 for nonmembers.

A study guide is included with this application. One must have an approved application on file at IIBEC to be eligible to take any exam. Approved applications are valid for **two** years and reapplication is required if the applicant does not earn the RRO title within that time period. **One must wait a minimum of four months to retest.**

As an organization focused on advancing the roofing, waterproofing and exterior wall professions, we look forward to receiving your application and encourage your active involvement in IIBEC.

Sincerely,

Alec Jeffries
Senior Director of Membership & Registrations

International Institute of Building Enclosure Consultants
434 Fayetteville Street Ste 2400
Raleigh, NC 27601
(T) 919-859-0742 (T) 800-828-1902
(F) 919-859-1328
www.iibec.org

APPLICATION FOR REGISTERED ROOF OBSERVER

TABLE OF CONTENTS

Please review the enclosed packet to verify that you have the following items:

Introduction.....	I-III
Sections 1 & 2	
Profile Information	1
Business Information	1
Sections 3 - 8	
Employment History	2
Personal Work History.....	2
Continuing Educational Hours	2
References	2
IIBEC Code of Ethics	2
Affidavit Authorization & Release	2
Attachment Sheet I (Employment History).....	3
Attachment Sheet II (Project Contact Register)	4
Attachment Sheet III (Continuing Educational Hours Summary)	5
Attachment Sheet IV (Reference Summary).....	6
Attachment Sheet V (Reference Form)	7
Attachment Sheet VI (Code of Ethics)	8-9
Attachment Sheet VII (Affidavit Form)	10
Payment Form	11
Checklist.....	12

INTRODUCTION

REGISTERED ROOF OBSERVER PROGRAM

PURPOSE

1. Establish a high standard for the profession of roof quality assurance observation.
2. Provide education, both primary and advanced, for the QA observer.
3. Encourage members to participate in the educational programs to maintain prescribed standard.
4. Advance the dignity and professionalism of the QA observer and discourage unethical practices.
5. Enlighten the construction industry and the public in general, regarding the value of qualified, knowledgeable quality assurance roof observers.
6. Promote cooperation between related trades to provide for a high level of construction standards.
7. Recognize those QA observers who have obtained a high level of proficiency and knowledge by granting them the title Registered Roof Observer (RRO).

THE EXAMINATION

The examination will be given at Measure Learning computer-based testing centers. The candidate must achieve a satisfactory score on the exam, which tests knowledge regarding the following types of roofing systems: single-ply, asphalt shingle, modified bitumen, built-up, wood, sprayed polyurethane foam, tile, metal, and slate.

Although not required, the following IIBEC courses are recommended for those pursuing this designation: Rooftop Quality Assurance, Building Envelope Quality Assurance and Roofing Technology and Science I and II.

EXAM ELIGIBILITY REQUIREMENTS

1. Applicant must read and write in English in order to sit for the exam.
2. Applicant must qualify in one of the following categories:
 - a. Employment as a QA inspector/ consultant in roofing for a cumulative period of 2 years.
 - b. Experience as a Registered Architect/Professional Engineer, Building Inspector/Official, and/or Facilities/Maintenance/Property Manager for a cumulative period of 2 years.
 - c. Experience in roof construction for a period of 2 years, as a roofer, roof foreman, roof superintendent, etc.
 - d. Employment as a roofing manufacturer's technical or sales representative for a period of 4 years.

The table below outlines related job titles and the responsibilities individuals in those occupations would perform related to the RRO.

<i>Job Position</i>	<i>Job Responsibilities as Related to RRO</i>
Architect/Professional Engineer	Knowledge of different roofing materials, and roof systems and installations when reviewing, specifying and inspecting construction projects
General/Roofing Contractor	Knowledge of different roofing materials, and roof systems and installations when reviewing, selecting, and inspecting construction projects.
Facilities/Maintenance/Property Manager	Knowledge of different roofing materials, and roof systems and installations when maintaining facilities.
Building Inspector/Official	Knowledge of different roofing materials, and roof systems and installations when reviewing and inspecting construction projects.
Roof Consultants	Knowledge of different roofing materials, and roof systems and installations when reviewing, specifying and inspecting construction projects. Provide technical support and advice during the roof system selection process.
Quality Assurance Observer	Knowledge of different roofing materials, and roof systems and installations when performing the duties of on-site roof observations at construction projects.
Material Manufacturers Sales/Technical Representative	Knowledge of different roofing materials, roof systems and installations when providing technical support before, during and after roof system selection and roof installations.

3. Applicant must accumulate a minimum of 12 Continuing Educational Hours (CEHs) by attending a minimum of 3 roofing-related seminars (see section 5). The applicant also agrees to continue his/her training and education by earning CEHs or in accordance with the operating procedures established by IIBEC. IIBEC's Roofing Technology and Science I and II, and the Rooftop Quality Assurance and Building Envelope Quality Assurance Courses are highly recommended for those taking the RRO Exam.
4. Applicant must establish that he/she has met certain minimum requirements regarding communication skills, personal work experience and other matters regarding character and ethics.
5. Applicant must complete and submit an RRO application to IIBEC headquarters allowing 90 days for processing prior to the exam along with the appropriate application processing fee.
6. Applicant shall have a strong moral and ethical character demonstrated by his/her references, experiences and professionalism.
7. Applicant shall always be totally objective, unbiased and impartial in his/her observations, recommendations and in all of his/her actions.
8. Applicant shall never have a conflict of interest or permit him/her to be placed in a position that would allow for a potential conflict of interest. Conflict of interest shall be defined as any activity or employment in which the applicant has any significant financial benefit or other interest, or acceptance of any contribution or benefit that could reasonably appear that such activity, employment, interest or contribution could compromise the individual's professional judgment or prevent the individual from serving in the best interest of the client or employer.

MAINTAINING STATUS

The Registered Roof Observer must continue his/her activities as a QA observer or in a job requiring the skills of a QA observer and renew his/her registration every year. Requirements include an annual renewal fee and the provision of information regarding continuing educational hours in accordance with the registration renewal procedures established by IIBEC. Registration renewal is the responsibility of the RRO.

Once the applicant has been registered as a QA observer, he/she must maintain his/her employment as outlined above. In the event the QA observer discontinues employment in the construction industry or takes employment with a firm that provides services that cause a conflict of interest, then he/she will forfeit his/her registration. Registration granted by IIBEC shall remain its property.

Note:

The intention of the RRO Registration Program is to provide a system that can withstand the scrutiny and criticism of the public sector and of governmental agencies. Registration must be meaningful and comprehensive to identify those observers with exemplary knowledge and skills for the betterment of the industry.



APPLICATION FOR REGISTERED ROOF OBSERVER

International Institute of Building Enclosure Consultants
 434 Fayetteville Street Ste 2400
 Raleigh, NC 27601
 (800) 828-1902 or (919) 859-0742
 Fax (919) 859-1328

Date _____

Type or Print Legibly Using Black Ink Pen

SECTION 1: PROFILE INFORMATION				
Full Name	First	Middle	Last	
Home Address	Street Number	Apt	Box	Road/Rural Route
	City	Country	State	Zip
Email				
Birth	Date	City	State	Citizenship
Have you ever applied for IIBEC Registered Roof Observer classification before? <input type="checkbox"/> Yes <input type="checkbox"/> No If yes, please give date of application:				
Are you a Contractor or employed by one? <input type="checkbox"/> Yes <input type="checkbox"/> No Type: <input type="checkbox"/> General <input type="checkbox"/> Roofing State and license number for each:				
Are you employed by or own a company that manufactures, distributes, or sells roofing products or materials? <input type="checkbox"/> Yes <input type="checkbox"/> No Identify:				
Do you derive your principal income as a roof consultant or quality assurance observer? <input type="checkbox"/> Yes <input type="checkbox"/> No If no, what percent of your income do you derive as a consultant? _____% QA observer _____%				
Do you have any conflict of interest (see page II, item 8 for definition), or do you work for, own, or have interest in any company having such conflicts? <input type="checkbox"/> Yes <input type="checkbox"/> No				
SECTION 2: BUSINESS INFORMATION				
Firm employed by: <input type="checkbox"/> Consulting <input type="checkbox"/> Architectural <input type="checkbox"/> Engineering <input type="checkbox"/> Contractor <input type="checkbox"/> Manufacturer <input type="checkbox"/> Distributor <input type="checkbox"/> Other				
Name of business:				
Business Street Address: _____ City: _____ State: _____ Zip: _____ Telephone: _____				
Organization: <input type="checkbox"/> Individual <input type="checkbox"/> Individual Proprietorship <input type="checkbox"/> Partnership <input type="checkbox"/> Corporation <input type="checkbox"/> Other (please specify): _____				

SECTION 3: EMPLOYMENT HISTORY

On Attachment Sheet I, provide information regarding your personal work history background and **experience directly related to roofing. Do not include employment in non-related fields.**

SECTION 4: PERSONAL WORK HISTORY

On Attachment Sheet II (with the major heading "PROJECT CONTACT REGISTER"), **list 7 or more projects** for which you claim personal work experience. The items below refer to services rendered or tasks performed by you, not by someone under your direction. YOUR experience as a roof quality assurance observer, or other position as specified on page I, is being evaluated, not your management ability or the experience of your company or your subordinates. Please verify phone numbers are correct before listing.

SECTION 5: CONTINUING EDUCATIONAL HOURS EARNED

On Attachment Sheet III, provide information regarding continuing educational hours earned through your attendance at seminars directly related to roofing. Attendance at a minimum of three programs (i.e.: IIBEC, AIA, CSI, BURSI or other approved educational courses) is required and documentation of such attendance must be provided. Programs must be technical in nature (not sales or product oriented). Online programs meeting these requirements are acceptable. Documentation should be in the form of a certificate or letter from the sponsoring organization stating the name of the course, date course was held, and number of credit hours awarded. A minimum of 12 credit hours from a minimum of 3 roofing-related seminars is required (credit hours must be earned within the last 10 years). There is a maximum of 16 hours accepted per program.

SECTION 6: REFERENCES

On Attachment Sheet IV, give names and addresses of five references, at least one of which is a Registered Roof Consultant, IIBEC Consultant Member, Registered Architect or Registered Engineer. References may not be related to the applicant. In addition, **only one** reference may be from a current employer or fellow employee. Each reference listed must have direct personal knowledge of your character, ethics, professional reputation and competence. Complete the top portion of the Reference Form (page 7) and make a copy of the form for each person listed on Attachment Sheet IV. Send the form to each person with instructions to return the completed form directly back to IIBEC. References can be e-mailed to: spatterson@iibec.org.

SECTION 7: CODE OF ETHICS FOR IIBEC

The Code of Ethics for IIBEC is included in this application. It outlines the obligations of the quality assurance observer to the public, the client or employer, the profession and the building industry. The Registered Roof Observer is required to promote and conform to these standards.

SECTION 8: AFFIDAVIT CERTIFICATION, AUTHORIZATION AND RELEASE

Please complete Attachment Sheet VII in the presence of a notary and submit to IIBEC with the application.

IMPORTANT: PLEASE MAKE A COPY OF THE ENTIRE COMPLETED APPLICATION BEFORE SENDING IT TO IIBEC. DO NOT DOUBLE SIDE THE ORIGINAL.

SECTION 3: EMPLOYMENT HISTORY

Name _____

Date _____

List in order, beginning with the first employer, your work history directly related to roofing. Do not include employment in non-related fields or employment. Add additional sheets as necessary.

DATE		(1) Company Name (2) Address (3) City, State, Zip (4) Title/Position	Description of Experience (Briefly in space provided)
From	To*		
		(1) (2) (3) (4)	
		(1) (2) (3) (4)	
		(1) (2) (3) (4)	
		(1) (2) (3) (4)	

* Type "Present" in this column to indicate your current employer. Include month(s) and year(s).

Name _____

Date _____

SECTION 4: PROJECT CONTACT REGISTER

Please complete this page with information indicative of the required years of experience.
Copy this page as additional space is needed.

Quality Assurance Observation

1. Project Name: _____
 Project Location: _____
 Project Contact: _____ Telephone: _____
 Date of Project: _____
2. Project Name: _____
 Project Location: _____
 Project Contact: _____ Telephone: _____
 Date of Project: _____
3. Project Name: _____
 Project Location: _____
 Project Contact: _____ Telephone: _____
 Date of Project: _____
4. Project Name: _____
 Project Location: _____
 Project Contact: _____ Telephone: _____
 Date of Project: _____
5. Project Name: _____
 Project Location: _____
 Project Contact: _____ Telephone: _____
 Date of Project: _____
6. Project Name: _____
 Project Location: _____
 Project Contact: _____ Telephone: _____
 Date of Project: _____
7. Project Name: _____
 Project Location: _____
 Project Contact: _____ Telephone: _____
 Date of Project: _____

***Include month(s) and year(s) Please list 7 project for which you claim personal work experience**

SECTION 5: CONTINUING EDUCATIONAL HOURS EARNED

Name _____

Date _____

Course Name	Presented By	Dates	Hours
		Total #	

Note: Certificates stating the name of the course, date, and number of technical hours must accompany this form to substantiate all points claimed. Acceptable programs must be technical in nature (not sales or product oriented). Continuing Educational Hours (CEHs) can be no older than 10 years. There is a maximum of 16 credit hours accepted per program. A minimum of 12 credit hours from a minimum of 3 roofing-related seminars is required. **Please list your continuing educational courses in chronological order!**

SECTION 6: REFERENCE SUMMARY

Name _____

Date _____

Name & Company	Address/City, State, Zip	Telephone and Position/Title

Note: Please complete the top portion of the reference form for each person listed above. Send directly to each reference, who will then send the form directly back to IIBEC.



REFERENCE FORM

Date _____

Dear _____ : (Print reference's name)

An application for Registered Roof Observer has been filed with the International Institute of Building Enclosure Consultants (IIBEC) by

_____ of _____, _____
(Applicant) (Company) (City/state)

Will you kindly give the information requested below, if known, and make any comments that may be of value in passing upon the applicant's qualifications.

Information secured from references is for the confidential use of IIBEC and the source and character of the information will not be divulged, except in special cases when required by law.

Both the applicant and the Association appreciate your cooperation in promptly furnishing the information requested.

GENERAL INFORMATION

- 1. Applicant's present position _____
- 2. Number of years known _____
- 3. Applicant's moral character, professional ethics and personal reputation are _____
- 4. How long has the applicant been engaged in actual roof observation work? _____
- 5. In your opinion is the applicant competent as a roof observer? _____
- 6. Are you related to the applicant? _____ If yes, how related _____

Remarks:

Signed _____	Are you a legally registered engineer? _____
Position _____	Are you a legally registered architect? _____
Business _____	Are you an IIBEC Consultant member? _____
Date _____	Are you a Registered Roof Consultant? _____
E-mail Address _____	

If, for some reason, you do not desire to serve as a reference for the applicant, please return this form to us with a comment to that effect.

PLEASE RETURN REFERENCE FORM DIRECTLY TO:

International Institute of Building Enclosure Consultants
434 Fayetteville Street Ste 2400
Raleigh, NC 27601
(T) 800-828-1902 or 919-859-0742 (F) 919-859-1328
E-mail: spatterson@iibec.org

CODE OF ETHICS
International Institute of Building Enclosure Consultants
Adopted July 17, 2001
Revised March 28, 2006
Revised September 19, 2015

Introduction: The International Institute of Building Enclosure Consultants (IIBEC) is dedicated to the highest standards of professionalism, integrity, and competence. The standards contained in this Code of Ethics (Code) are statements of ethical principles by which the professional conduct and obligations of all IIBEC members and registrants shall be guided.

Under the IIBEC Bylaws, all IIBEC members and registrants are required to comply with the Code of Ethics and to report any observed violations. Adherence to this Code must be above reproach and beyond the influence of competing interests. Even the appearance of a conflict of interest shall be avoided.

The standards contained in this Code of Ethics are statements of ethical principles having broad applicability to members and registrants of IIBEC.

Members and registrants of IIBEC shall recognize that their profession and their practice may be governed by various laws and regulations regarding professional registration and the conduct of trade. It is their responsibility, therefore, to be familiar with those laws and regulations and to conduct themselves accordingly.

General Obligations: Members and registrants shall maintain and further their knowledge of the science in which they practice, and shall maintain the highest possible standard of professional judgment and conduct. Members and registrants shall conduct their practice honestly and impartially, serving with integrity their clients, employers, and/or the public. Learned and uncompromised professional judgment should take precedence over any other motive.

Obligation to the Public: Members and registrants shall uphold the letter and spirit of the ethical standards governing their professional affairs and shall consider the full impact of their actions on the community at large.

Fundamental Canons

Members and registrants of IIBEC, in the performance of their duties, shall:

1. Hold paramount the safety, health, and welfare of the public;
2. Uphold the letter and spirit of the ethical standards governing their professional affairs, considering the full impact of their actions on the community at large and conducting themselves in a fashion that brings credit to themselves, their employers, their peers, and their profession; and
3. Recognize the value and contributions of others engaged in all aspects of consultation, design, and construction.

Rules of Practice

1. Members and registrants shall hold paramount the safety, health, and welfare of the public in the performance of their duties.
 - a. If a member's or registrant's judgment is overruled under circumstances that, in the opinion and best professional judgment of the member or registrant, endanger life or property, the member or registrant shall:
 - i. Advise his or her employer and/or client about the decision,
 - ii. Refuse to consent to the decision, and
 - iii. Notify the appropriate building authority charged with the enforcement of the applicable laws or regulations.
 - b. Members or registrants who have knowledge of any alleged violations of this Code shall report them to the appropriate public authorities and IIBEC, and shall cooperate with appropriate public authorities and RCI in providing such information as may be applicable.
2. Members and registrants shall not permit the use of their names or firms nor associate in business ventures with any person or firm that they have reason to believe is engaged in fraudulent or dishonest business or professional practices.
3. Members and registrants shall uphold the letter and spirit of the ethical standards governing their professional affairs, consider the full impact of their actions on the community at large, and conduct themselves in a fashion that brings credit to themselves, their employers, and their profession by:
 - a. Engaging only in accurate, appropriate, and truthful promotion of their practice;
 - b. Being respectful of the rights of others in obtaining work or employment;
 - c. Making only accurate, truthful, and appropriate statements or claims about their qualifications, experiences, or performance;

- d. Being objective and truthful in reports, statements, testimony, and on social media;
 - e. Preserving the confidentiality of their clients and employers and serving each in a professional and competent manner;
 - f. Exercising unprejudiced and unbiased judgment and conduct when performing all services;
 - g. Undertaking assignments only when qualified by education and experience in the specific technical fields involved;
 - h. Declining any activity or employment, avoiding any financial or other interest, and refusing any contribution if it would reasonably appear that such activity, employment, interest, or contribution could compromise their judgment or conduct or prevent them from serving the best interests of their clients or employers, without making full disclosure to the client and obtaining the client's consent thereto; and
 - i. Neither offering nor making any payment or gift to any public official, private client, or industry representative with the intent of influencing that person's judgment or decision in connection with an existing or prospective project in which the member/registrant is interested.
4. Members and registrants shall recognize the value and contributions of others engaged in all aspects of consultation, design, and construction. This means they shall:
 - a. Refrain from making false statements about the work of others and shall not maliciously injure or attempt to injure the prospects, practice, or employment position of others;
 - b. Encourage professional education and research, as well as the development and dissemination of information related to all aspects of consultation, design, and construction of roofing, waterproofing, and exterior wall systems; and
 - c. Take into account applicable laws and regulations and may rely on the advice of other competent and qualified persons as to the intent and meaning of such applicable laws and regulations.
 5. Members and registrants shall not accept compensation—financial or otherwise—from more than one party for services on the same project, or for services pertaining to the same project, unless the circumstances are fully disclosed.
 6. Members and registrants shall not intentionally or recklessly mislead existing or prospective clients about the results that can be achieved through the use of the members' or registrants' services or products, nor shall the members or registrants state that they can achieve results by means that violate applicable law or the Code.
 7. Members and registrants having substantial information leading to a reasonable belief that another member or registrant has committed a violation of this Code that raises a serious question as to the honesty, trustworthiness, or fitness of the other member or registrant shall file a complaint with the IIBEC Ethics Committee.
 8. Members and registrants shall maintain and further their knowledge of the science, principles, and ethics of their profession.
 9. Members and registrants shall be scrupulously honest in their control and spending of monies, and promote effective use of resources through open, honest, and impartial service with fidelity to the public, employers, associates, and clients.
 10. Members and registrants shall approve or issue only those documents reviewed or prepared under their direct control and supervision that are determined to be safe for public health and welfare, in conformity with accepted industry standards and applicable laws.
 11. Certain practices are not in themselves unethical, unprofessional, or contrary to any policy of IIBEC, and IIBEC members and registrants are free to decide for themselves whether to engage in any of these practices, unless in violation of an applicable law. These may include the following:
 - a. Contributing his/her services or anything of value to those endeavors that the member deems worthy;
 - b. Participating in the political process and contributing time and money to political campaigns;
 - c. Submitting competitive bids or price quotations, including in circumstances where price is the sole or principal consideration in the selection of a consultant;
 - d. Providing discounts; or
 - e. Providing pro bono services.

Enforcement and Amendment

1. Enforcement of the Code of Ethics is administered through the IIBEC Ethics Committee, appointed by the IIBEC Board of Directors, and as set forth in the *IIBEC Ethics Administrative Procedures*.
2. The IIBEC Code of Ethics may be amended by the IIBEC Board of Directors upon a two-thirds vote of the Board.

AFFIDAVIT REGISTRATION AUTHORIZATION AND RELEASE (to be notarized)

State of _____

County of _____

_____, being first duly sworn, deposes and says:

(Applicant's Name)

I, the Applicant named above, have read the contents hereof, and to the best of my knowledge and belief the statements contained in this application are true in substance and effect and are made in good faith. I hereby subscribe to and agree to conform to the Code of Ethics for the International Institute of Building Enclosure Consultants (IIBEC). I shall endeavor never to place myself in a conflict of interest or permit myself to be placed in a position that would allow for a potential conflict of interest. Conflict of interest shall be defined as any activity or employment having any significant financial or other interest, or acceptance of any contribution if it would reasonably appear that such activity, employment, interest or contribution could compromise my professional and objective judgment as a Registered Roof Observer or prevent me from serving the best interest of my client.

I also hereby authorize any individual, company or institution with whom I have been associated to furnish IIBEC with any information concerning my qualifications for Registered Roof Observer which they have on record or otherwise, and do hereby release the individual, company or institution and all individuals connected therewith from all liability for any damage whatsoever incurred by me as a result of their furnishing such information.

Subscribed and sworn to before me this _____ day of _____, 20____

(Signature of Applicant)

(SEAL)
My Commission expires _____

(Signature of Notary Public)



Application for Registered Roof Observer Payment Form

Enclosed is a check in the amount of: \$375.00 member fee \$475.00 nonmember fee

Expediting fee: \$50.00 member fee \$100.00 nonmember

Charge my VISA MasterCard American Express Discover for:

\$375.00 member fee \$475.00 nonmember fee

\$50.00 member expediting fee \$100.00 nonmember expediting
fee

Name _____ Telephone _____

Account Number _____ Expiration Date _____

3- or 4-Digit Verification Value Code _____

Signature _____ Date _____

Bill to Address: (If different from what is listed on the application)

Address: _____

City: _____ State: _____ Zip code: _____

Please return the completed single-sided application along with payment in US dollars to: (email delivery is preferred). *Please allow 90 days for application processing. Applications will be processed within 60 days for the expediting fee listed above. Once the application is submitted, all outstanding information must be received within 1 year or the application will become null and void.

**International Institute of Building Enclosure Consultants
434 Fayetteville Street, Ste 2400
Raleigh, NC 27601
(T) 919-859-0742 or 800-828-1902 (F) 919-859-1328
Email: spatterson@iibec.org**

CHECKLIST TO ACCOMPANY REGISTERED ROOF OBSERVER APPLICATION

Applicant's Name _____

Date _____

A check or initial in the block at the right indicates that you have completed that requirement of the application.

1. Application fee enclosed (\$375.00 members/\$475.00 nonmembers).....
2. Completed Sections 1 and 2 of the application.....
3. Section 3 of the application - Attachment Sheet I:
 - a. All dates are listed.....
 - b. All employers' names and addresses are listed.....
 - c. Brief description of experience under each employer is listed.....
4. Section 4 of application - Attachment Sheet II:
 - a. Each project for which I claim experience is listed on Attachment Sheet II.....
 - b. All names, addresses, telephone numbers and dates of projects listed
 - c. All projects listed represent my experience (not someone under my direction).....
 - d. All projects claimed truly reflect worthy experience under the appropriate heading.....
5. Section 5 of application - Attachment Sheet III:
 - a. All course names, sponsoring organization, dates and credit hours claimed listed
 - b. I have attended a minimum of 3 roofing seminars (12 hours) dealing with roofing technology.....
6. Section 6 of application:
 - a. Listed on Attachment Sheet IV are five references, one of whom is a Registered Roof Consultant, IIBEC Consultant Member, Registered Architect, or Professional Engineer.....
 - b. None of the references is a relative.....
 - c. No more than one of these references is a present employer or fellow employee from current firm.....
 - d. Made copies of Attachment Sheet V for EACH reference. Completed top part only for each.....
 - e. Reference forms sent directly to each reference.....
7. Section 7 of application: Attachment Sheet VI
I have read and agree to abide by the IIBEC Code of Ethics
8. Section 8 of application: Attachment Sheet VII
 - a. Affidavit has been executed and notarized
9. Once an application has been submitted to IIBEC, the time limit to provide all outstanding information is one year.

When complete and all spaces are checked, sign below, enclose this checklist, and send the completed application form to IIBEC (do not fold or double side, please). Allow 90 days for processing. **MAKE A COPY OF YOUR COMPLETED APPLICATION BEFORE SENDING TO IIBEC** for your own protection.

I have completed the application as required by the Association, have checked all details and entries, and hereby submit said application for registration. I understand that registration is contingent upon meeting the requirements of IIBEC and successful completion of the required examination.

Signature of Applicant



STUDY GUIDE
For the
REGISTERED ROOF OBSERVER (RRO®) EXAM

Prepared By
RRO Examination Development Task Force

International Institute of Building Enclosure Consultants

434 Fayetteville Street Ste 2400

Raleigh, NC 27601

800-828-1902 919-859-0742

RRO Study Guide

Table of Contents

	Page(s)
Introduction	1
References	2
Test Objectives	3
Sample Questions.....	4-9
Exhibits.....	10-11
Answers to Sample Questions.....	13



STUDY GUIDE RRO EXAMINATION

International Institute of Building Enclosure Consultants (IIBEC)

INTRODUCTION

One early goal of IIBEC was to develop a recognized and highly regarded registration program for Roof Quality Assurance Observers. The registration program was authorized by the IIBEC Board of Directors in 1989 and implemented in 1992. The primary beneficiaries of this program are the public, the roofing industry, and those who become registered.

IIBEC offers its RRO Program to all applicants, members and non-members. Registration is a two-part program based on an application process along with satisfactory performance on a comprehensive computer-based examination.

This study guide outlines subjects that are addressed in the examination; however, it is not intended to be an inclusive listing of every topic. This document is strictly a guide.

The latest RRO exam revision was completed in December 2017 in compliance with the Standard for the Accreditation of Certification Programs as published by the National Commission for Certifying Agencies (NCCA). A committee of subject matter experts followed a rigorous psychometric process in its development.

The examination is not tailored to any one particular area of roof observation, or to the design and construction practices unique to any geographic area. It deals primarily with roof observations in general. It may include all phases of roof observations (methodology and construction), both steep and low-slope roofing, and all systems (shingle, tile, slate, single-ply, modified bitumen, built-up, wood, metal and spray applied systems).

In order to receive a passing score on the examination, the examinee must be thoroughly familiar with the basic methodology of Q.A.O. and have a broad knowledge of: basic roof science, documentation and reporting, field testing observation, construction documents, roles, responsibilities and ethics, and roof systems and materials. Preparation for the exam is essential and is unique to each individual depending on one's experience.

The exam is offered online by Meazure Learning, a computer-based testing company. It consists of 75 choice questions and is up to three hours in duration. It is a multiple choice exam.

Consult <https://www.assessments.meazurelearning.com/test-site-cities/> for a conveniently located testing site near you.

Approved applications have a two-year shelf life; and once the application has expired, reapplication will be required. **Candidates who do not initially pass an exam will have the option to retry every four months**

Although not required, the following IIBEC education programs may be useful for anyone pursuing this designation: Roof Technology and Science I, Roof Technology and Science II, Reroofing, Rooftop Quality Assurance, Roof Warranties and Failures.

References*

A sample of documents/references that were used to develop the RRO exam is as follows:

<i>Title</i>	<i>Author</i>	<i>Publication Date</i>
1. Construction Specifications Principles and Applications	H. Meier/D. Wyatt	2008
2. Manual of Low-Slope Roof Systems – Fourth Edition	C.W. Griffin & R.L. Fricklas	2006
3. NRCA Roofing Manual: Architectural Metal Flashings	NRCA	2018
4. NRCA Roofing Manual: Membrane Roof Systems	NRCA	2019
5. NRCA Roofing Manual: Metal Panel & SPF Roof Systems	NRCA	2016
6. NRCA Steep-Slope Roofing Systems	NRCA	2017
7. IIBEC Code of Ethics	IIBEC	2012
8. RCI Manual of Practice	RCI (now IIBEC)	2010
9. The Project Resource Manual : CSI Manual of Practice, 5 th Edition	CSI	2005

*The references listed above are only some of the many that were used in the development of this exam. This is meant to serve as a guide to illustrate the types of references used; this is not a recommendation or suggestion to purchase all of the publications listed. The most useful tool in preparation for the exam is the following list of skills, knowledge and responsibilities identified by the task force as those associated with acceptable performance within the quality assurance observer profession. It is recommended that the applicant review this list as it relates to one’s experience/skill set and then prepare accordingly with the courses and/or publications which may be helpful to the individual.

As part of the exam revision process, the committee of subject matter experts systematically compiled a list of objectives that relate to the responsibilities, knowledge, and skills associated with acceptable performance within the quality assurance observer profession. This list provided the organizational framework for the exam and is attached below.

Sections	Section/Objective Title	Percentage of questions from section on exam
Section 1	Basic Roof Science	8%
Objective 1.1	Describe a basic understanding of thermal moisture, drainage and wind principles related to roof construction.	
Section 2	Documentation and Reporting	9%
Objective 2.1	Describe the monitoring, recording and reporting of roof installation.	
Objective 2.2	Demonstrate basic math operations as related to roof construction.	
Section 3	Field Testing Observation	5%
Objective 3.1	Describe field testing procedures.	
Section 4	Construction Documents	11%
Objective 4.1	Describe standards and construction documents.	
Section 5	Roles, Responsibilities and Ethics	19%
Objective 5.1	Describe the roles and responsibilities of the RRO.	
Objective 5.2	Demonstrate project-specific roles.	
Objective 5.3	Demonstrate ethics governing the behavior of the RRO.	
Objective 5.4	Demonstrate appropriate PPE, personal safety requirements and job site hazards.	
Section 6	Roof Systems and Materials	48%
Objective 6.1	Describe low-slope roofing systems	
Objective 6.2	Describe steep-slope roof systems	
Objective 6.3	Describe metal roof systems	
Objective 6.4	Describe liquid membranes	
Objective 6.5	Describe sheet metal flashings	
Objective 6.6	Describe roof accessories	
Objective 6.7	Describe roof insulation	
Objective 6.8	Describe roof deck types	

RRO Exam Sample Questions

Refer to Exhibit #1.

1. Which two materials would be appropriate for item A shown in the exhibit? (Choose two.)
 - A. glass fiber insulation
 - B. polyisocyanurate insulation
 - C. polyurethane insulation
 - D. mineral wool insulation

2. When is it appropriate for a change directive to be issued?
 - A. When total agreement on the terms of the change order cannot be reached in a timely manner.
 - B. When the owner and contractor have agreed on the change in contract amount and time after discovery of an unforeseen condition.
 - C. When change in the work exceeds 10% of the contract amount.
 - D. When the RRO submits a statement of non-compliance.

Refer to Exhibit #2

3. Referring to the exhibit, which total percent of the project is complete?
 - A. 34%
 - B. 56%
 - C. 63%
 - D. 72%

4. Who controls the delivery, storage, and handling required for project materials?
 - A. the designer of record
 - B. the roof observer
 - C. the building owner
 - D. the contractor

5. Who is responsible for providing the RRO with personal protection equipment?
 - A. project manager
 - B. contractor
 - C. RRO's employer
 - D. building owner

6. A contractor is installing an SPF roof.

At a minimum, how many degrees should the ambient temperature be above the dew point for this roof?

- A. 2 degrees F [1.1 degrees C]
- B. 5 degrees F [2.8 degrees C]
- C. 7 degrees F [3.9 degrees C]
- D. 10 degrees F [5.5 degrees C]

8. A coating is being applied over an existing metal roof.

Which instrument will measure the thickness of the coating during application?

- A. optical comparator
- B. wet-and-dry-bulb psychrometer
- C. wet-mil gauge
- D. loupe

8. According to NRCA, which two metals are solderable? (Choose two.)

- A. prefinished aluminum
- B. galvanized steel
- C. galvalume
- D. stainless steel

9. When installing fire- and pressure-treated wood shake and shingles, which nail must be used?

- A. copper
- B. 316 stainless steel
- C. electro-galvanized steel
- D. hot-dipped galvanized steel

10. Which two deck types are considered nailable? (Choose two.)

- A. precast concrete
- B. steel deck
- C. light-weight insulating concrete
- D. channel slabs

11. The RRO is observing the Contractor install a 1/2" (13 mm) wood fiber cover board over the base layer of insulation; however the Construction Documents state that a 3/4" (19 mm) perlite cover board is to be installed. What should the RRO do?
- A. Assume that the 1/2" (13 mm) wood fiber was approved.
 - B. Assume that the Contractor is not installing the correct material.
 - C. Contact the Owner immediately.
 - D. Notify the Contractor, record the deviation and contact the Designer Authority.
12. How would a change to the Specifications be made prior to the submittal of bids?
- a. Change Order
 - b. Change Directive
 - c. Purchase Order
 - d. Addendum
13. Which of the following seaming procedures is appropriate for TPO membranes?
- A. Hot-air welding
 - B. Solvent-welding
 - C. Liquid-applied adhesive
 - D. Mastic-applied
14. The RRO observes that the temperature of the roofing asphalt at the point of application is too low. How should the RRO determine what the proper asphalt temperature at the point of application is?
- A. Review the flash point of the asphalt.
 - B. Review the finish blowing temperature of the asphalt.
 - C. Review the EVT of the asphalt.
 - D. Review the temperature gauge at the asphalt kettle.
15. Which of the following could be a cause of blistering on an SBS roof?
- A. Voids in the interply moppings
 - B. Excessive amounts of asphalt
 - C. Incorrect type of asphalt
 - D. Improper installation of the underlayment
16. Which of the following surface textures are acceptable for SPF?
- A. Smooth, orange peel, coarse orange peel, or popcorn
 - B. Smooth, orange peel, coarse orange peel, or treebark
 - C. Smooth, orange peel, popcorn or verge of popcorn
 - D. Smooth, orange peel, coarse orange peel, or verge of popcorn

17. Per OSHA, what is the proper distance from the wall that the base of a ladder should be placed?
- A. One-fifth of the working height
 - B. One-fourth of the working height
 - C. One-third of the working height
 - D. One-half of the working height
18. The RRO would be involved in which of the following tasks:
- A. Direct construction means and methods
 - B. Document and quantify unforeseen conditions
 - C. Accept material substitutions
 - D. Help enforce project schedule
19. The RRO is reviewing the installation of a roof system over a steel deck. The RRO observes that the deck has been modified in order to accommodate the installation of piping with an opening between 8 in. to 13 in. (200 mm to 325 mm) in diameter. The RRO is concerned about the integrity of the deck around this opening. What action should the RRO take?
- A. Tell the Roofing Contractor to remove the piping and repair the deck opening.
 - B. Inform the Roofing Contractor that plate reinforcement is required over the top of the deck due to the size of the opening.
 - C. Inform the Roofing Contractor that plate reinforcement is required on the underside of the deck due to the size of the opening.
 - D. Document the condition and contact the Designer of Record for direction.
20. A roof is 85 squares in area. The Contractor has $\frac{1}{8}$ th of the total roof left to complete. What area has been completed so far?
- A. 10 squares
 - B. 70 squares
 - C. 1,063 sq. ft. (99 sq. m.)
 - D. 7,438 sq. ft. (691 sq. m.)
21. When installing asphalt shingle on a plywood deck, what is the MINIMUM depth the nails should penetrate through the plywood deck?
- A. $\frac{1}{8}$ " (3 mm)
 - B. $\frac{1}{4}$ " (6 mm)
 - C. $\frac{1}{2}$ " (13 mm)
 - D. $\frac{3}{4}$ " (19 mm)

22. According to the NRCA Roofing Manual, how often should a termination bar be fastened on single-ply base flashings?
- A. 6" (150 mm)
 - B. 8" (200 mm)
 - C. 12" (300 mm)
 - D. 18" (450 mm)
23. What is the MAXIMUM roof slope recommended for the application of a coal-tar roof?
- A. Less than $\frac{1}{4}$ inch per foot
 - B. Less than $\frac{1}{2}$ inch per foot
 - C. Less than $\frac{3}{4}$ inch per foot
 - D. Less than 1 inch per foot
24. Proper documentation of Contractor manpower, crew size, weather conditions, and weather related work stoppages can be used to determine which of the following?
- A. If the Contractor's crews are being efficient with the installation of the material
 - B. If the Contractor should be paid for the work completed
 - C. If the RRO should direct the contractor to add manpower
 - D. If contract time extensions are granted, or if financial penalties are imposed
25. ASTM D312 - Standard Specification for Asphalt Used in Roofing lists four types of roofing asphalt based on resistance to flow. The preferred type of asphalt for a built-up membrane being installed on a roof having a slope greater than 1:12 is:
- A. Type I Asphalt.
 - B. Type II Asphalt.
 - C. Type III Asphalt.
 - D. Type IV Asphalt.
26. What information should be contained in the RRO's daily report?
- A. Work activities, installation procedures, and the RRO's opinion of Contractor performance
 - B. Work activities, materials being used, and installation procedures
 - C. Work activities, equipment being used, and number of apprentices on the job
 - D. Work activities, Contractor break times, and weather conditions

27. In what Division in the CSI Specification Format would the RRO expect to find criteria for thermal roof insulation?
- A. Division 6
 - B. Division 7
 - C. Division 8
 - D. Division 9
28. NRCA recommends that the board size of polyisocyanurate roof insulation in adhered application not exceed:
- A. 2' x 4' (600 x 1200 mm)
 - B. 3' x 4' (900 x 1200 mm)
 - C. 4' x 4' (1200 x 1200 mm)
 - D. 4' x 8' (1200 x 2400 mm)
29. The RRO is observing the installation of a slate roof system with a pitch of 10:12. What is the recommended head lap for 12" x 24" (300 mm x 600 mm) slate?
- A. 2" (50 mm) head lap
 - B. 3" (75 mm) head lap
 - C. 4" (100 mm) head lap
 - D. 6" (150 mm) head lap
30. When on site, the RRO observes the Contractor is not properly storing material on a daily basis. What is the appropriate action the RRO should take?
- A. Record observations in the field report and report the condition to the Contractor and Design Authority.
 - B. Inform the Contractor of the discrepancy and give the Contractor the opportunity to correct the problem.
 - C. Inform the Owner that the Contractor is not complying with the Specifications.
 - D. Assist the Contractor with correcting the discrepancy.

Exhibit #1

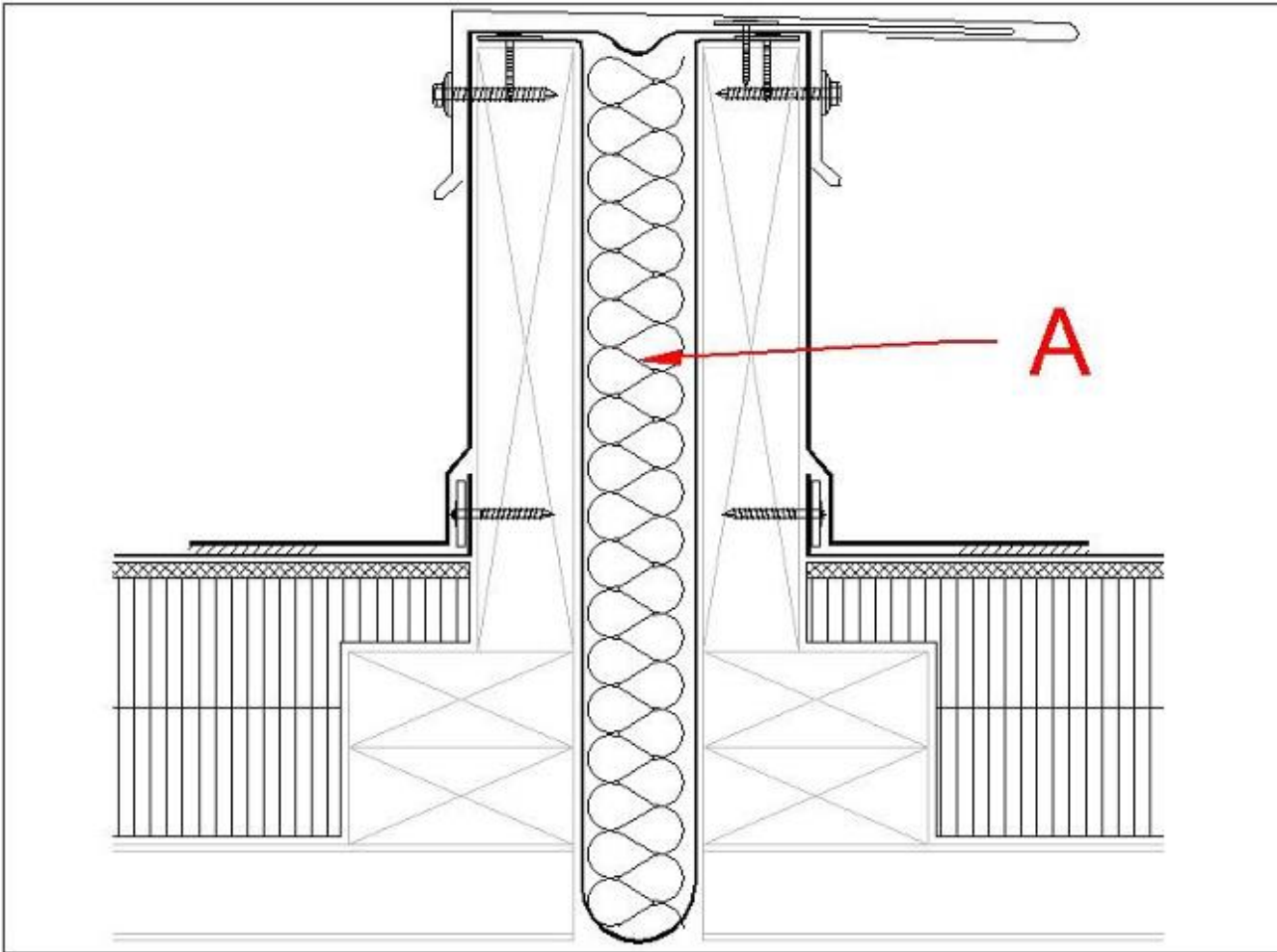
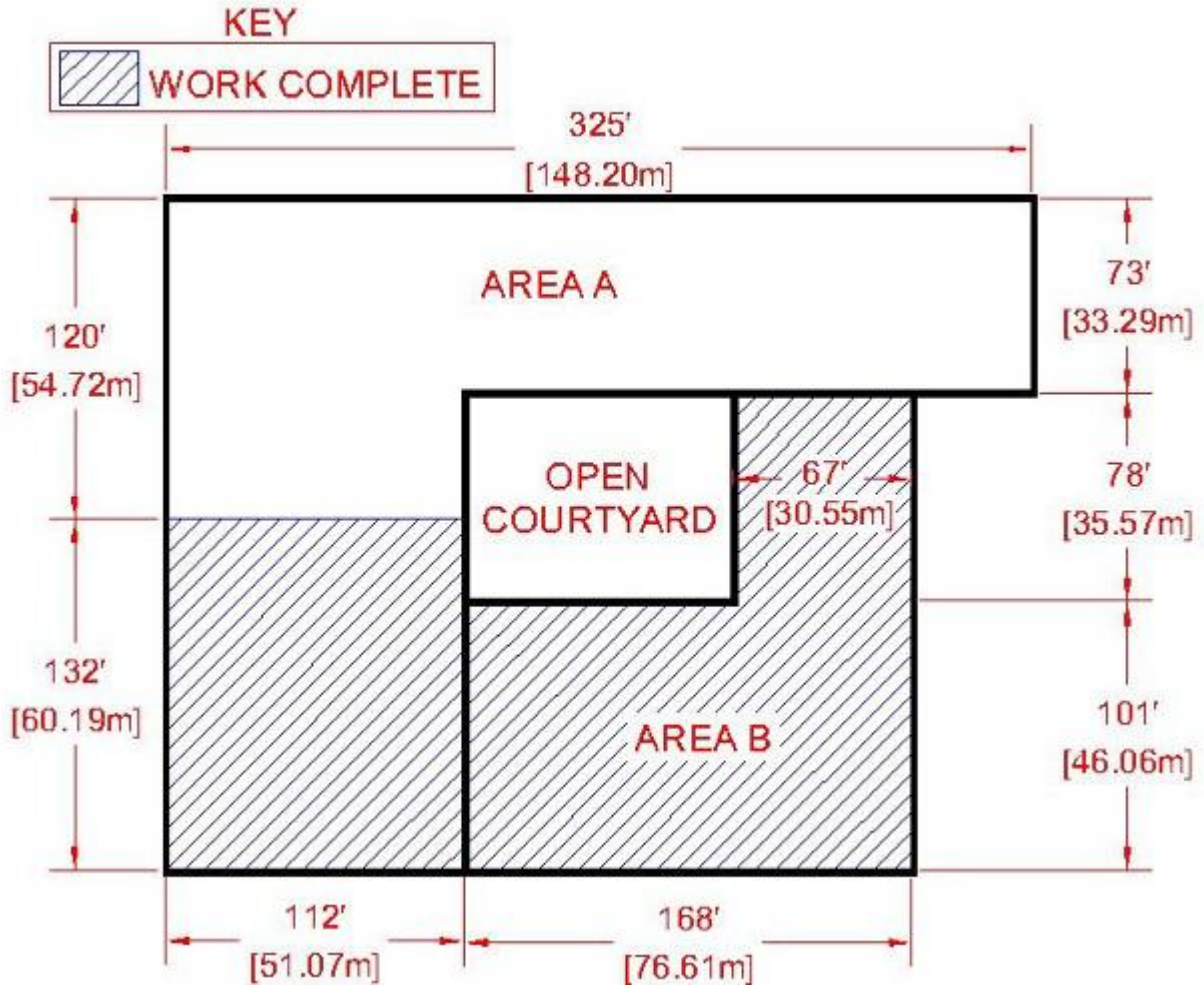

Exhibit #2



Answers to Sample Questions

Note your answers. Review the appropriate document(s) in those areas to better understand the rationale behind the indicated correct answer.

The following courses/course manuals provided by IIBEC are highly recommended for those pursuing the RRO designation: **Reroofing, Roofing Technology and Science I and II, Rooftop Quality Assurance, Roof Warranties and Failures.**

1. A & D
2. A
3. B
4. D
5. C
6. B
7. C
8. B & D
9. B
10. B & C
11. D
12. D
13. A
14. C
15. A
16. D
17. B
18. B
19. D
20. D
21. A
22. C
23. A
24. D
25. D
26. B
27. B
28. C
29. B
30. A