

BUILDING ENVELOPE TECHNOLOGY SYMPOSIUM

A FLASH IN THE PAN: A FIELD GUIDE FOR WINDOWS AND DOORS

ROBERT BATEMAN, AIA

SIMPSON, GUMPERTZ, AND HEGER, INC., SAN FRANCISCO, CA



RCI, Inc.®

ABSTRACT

This article will review the many varieties of flashing for windows and doorsills and answer why some forms can perform better and what materials are available. The presentation will refer to and review the latest ASTM E 2112-07 provisions recommending sill pans for windows and doors and presenting dimensions and configurations. This session will introduce a new system of classification used to identify and differentiate various sill pan flashings. This knowledge will assist designers, specifiers, and builders in the selection of effective details for waterproofing windows and doors.

SPEAKER

ROBERT BATEMAN

ROBERT BATEMAN has worked 25 years for several A/E firms as an architect and currently practices as a staff consultant specializing in waterproofing the exterior building envelope. He has been involved in the forensic investigation and repair design for residential, multifamily, commercial, and institutional buildings, including litigation support and expert witness testimony. He has been certified as a building inspector and plans examiner by ICC. Bateman has received a B-1 general building contractor license from California. He has actively participated with standards development for ASTM E 2112-01 and the details and appendix on sill pan flashing for the latest ASTM E 2112 -07. Robert has presented at national building and design organizations and trade shows, including RCI's SoCal Chapter. He has published peer-reviewed papers for ASTM and BETEC on building envelope detailing and window flashing. He is the author of "*Nail-on Windows - Installation Procedures for Windows and Sliding Glass Doors*," published in 1995.

A FLASH IN THE PAN: A FIELD GUIDE FOR WINDOWS AND DOORS

WHAT'S NEW

The latest standard for window and door installation has recently hit the street. The 2007 edition of ASTM E 2112, *Standard Practice for Installation of Exterior Windows Doors and Skylights*, has the guidelines for sill pan flashings revised, reorganized, and compiled in one section. This new standard recommends sill pan flashing under all windows and doors for low-rise residential and light commercial buildings with a few generalized exceptions noted.

The 2006 International Building Code (IBC) is now generally adopted and recognized as the single national building code in the United States. It has new requirements that address the importance of flashings for the weather protection of buildings.

Although ASTM E 2112-07 defers to window and door manufacturers for installation instructions, it remains the default voluntary standard if there are no specific recommendations from the manufacturer. Also, if there's no flashing design provided

on the construction documents for a particular building project, then ASTM E 2112 provides guidance.

A complete sill pan flashing assembly is shown in ASTM E 2112 (See *Figures 1 and 3*). The conceptual configuration illustrates and identifies the necessary parts of the sill pan flashing for a window. A door's sill pan flashing would be similar but adjusted for the substrate and floor level conditions on either side of the threshold. What is important about the ASTM sill pan flashing is the configuration and all the parts identified to make it a complete pan.

Sill flashing definitions can be found in ASTM and other sources. Useful terms for evaluating sill flashing assemblies include:

- Sill pan – The horizontal bottom part of a window or door¹
- Pan Flashing – A type of flashing used at the base of large openings or penetrations such as doors or windows. Pan flashings are designed to collect water and drain water direct-

ly to the exterior or onto the weather-resistive barrier. Pan flashings have an upturned inner leg and upturned end legs, which form a three-sided pan.²

- Sill Protection – A water-resistant covering provided for sills of rough openings that lack a true pan feature³

These terms help to differentiate different shapes and configurations of sill pan flashings. Other sill pan configurations without all the parts may not be effective at controlling leaks. The sill pan flashing shown in ASTM E 2112 is a complete assembly that does the most to manage incidental water (see *Figure 5*).

ASTM E 2112-07 is intended to include recommendations for different building construction types, such as barrier wall (solid brick, masonry, concrete, precast and metal/composite panels) and drainage walls (siding, paneling, stucco, and certain veneer claddings). It has the most comprehensive descriptions and illustrations for framed walls – wood or metal. This paper will also focus on the pan configuration typically used with framed walls with sheathing supporting a concealed water-resistive barrier (WRB), e.g. building paper or housewrap (See *Figure 2*). The *Field Guide* (see *Appendix 2*) will include all types of sill pan flashing examples.

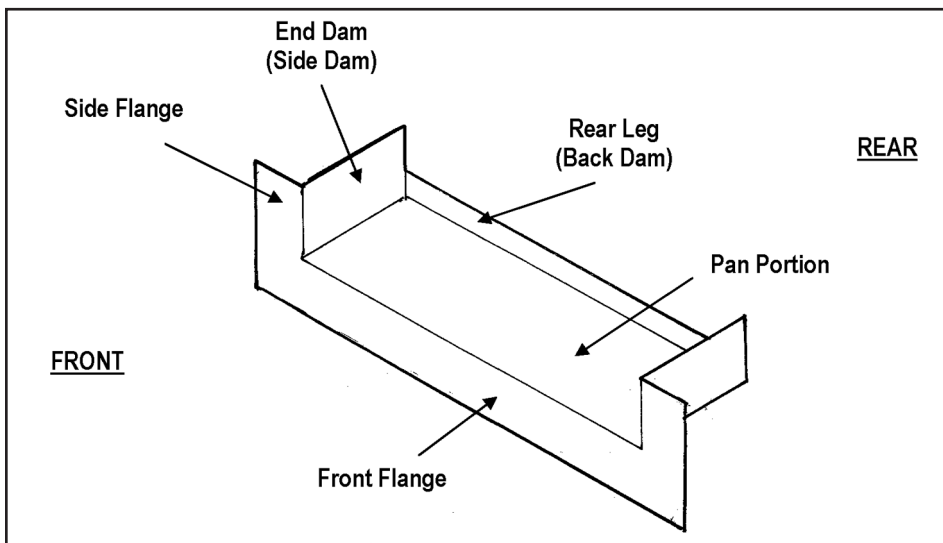

Figure 1 – Sill pan flashing configuration (based on ASTM E 2112).

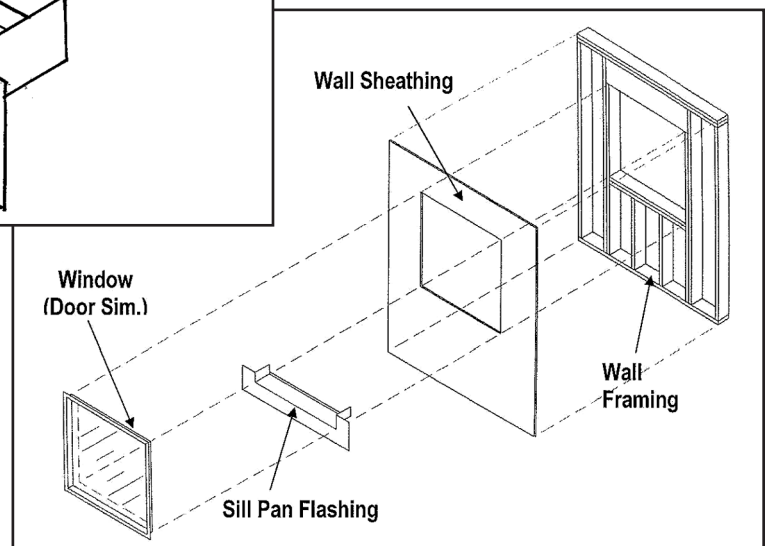

Figure 2 – Sill pan flashing in sheathed wall framing opening.

Rigid Sheet	1 piece or multiple pieces	Type I
Rigid Sheet	Multiple pieces	Type II
Flexible Membrane	1 piece or multiple pieces	Type III
Combination Systems	Multiple pieces	Type IV
Liquid Membrane	Continuous coating	Type V

(Based on and expanded from ASTM E 2112-07, Table 5.)

Table 1 - Types of Pan Flashing - Materials

When the WRB is behind the exterior cladding with concealed drainage walls, the integrated flashing can be chosen from a variety of materials. ASTM E 2112-07 recognizes four different flashing material and fabrication methods available. *Table 1* shows an expanded table based on ASTM's Table 5 that is revised to include liquid-applied coatings ("liquid membrane"), i.e., Type V.

The very recent use of vapor-permeable, liquid-applied WRB has not yet been addressed by ASTM E 2112. Although recently promoted for commercial buildings, liquid-applied flashings and liquid-applied weather barriers are more common with drainage barrier EIFS applications primarily in the residential market. The ASTM Table 5 could be modified in the future to include liquid-applied flashings and identified as Type V.

WHAT'S GOOD

With the recent attention being paid to the importance of sill pan flashings, there are more references available addressing the subject. The 2006 IBC and ASTM E 2112-07 have examples with some good information.

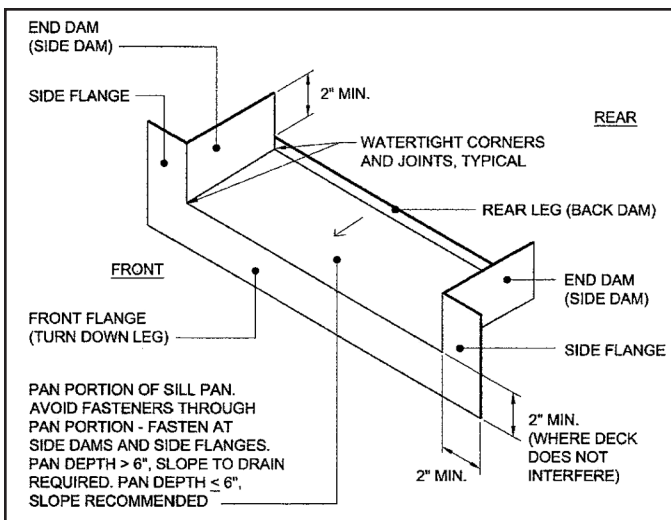

Figure 3 - Sill pan flashing configuration (excerpt from ASTM E 2112-07, Figure A3.4).

Construction Documents

2006 IBC, Section 106.1.3, requires construction documents to show details of the "...exterior wall envelope as required, including flashing, ...corners, end details, ...water-resistive membrane and details around openings." This code requirement should improve the quality of building plans.

Perimeter Flashing

Weather protection is emphasized in 2006 IBC, Section 1403.2. Opening flashing is spelled out in 2006 IBC, Sec. 1405.3, which notes, "[F]lashing shall be installed at the perimeters of exterior door and window assemblies." This code requirement should improve the attention builders apply to construction.

Sill Pan Flashing

The compiled section on pan flashing in ASTM E 2112-07 is now easier to navigate. There are minimum dimensions provided for pan flashings. The pan illustrations are shown in three dimensions so that the critical sill-jamb corners can be shown to be uniform and continuous (see *Figure 3*). Different materials and fabrications are illustrated (see *Appendix 1*).

The pan configuration is shown and defined to contain and

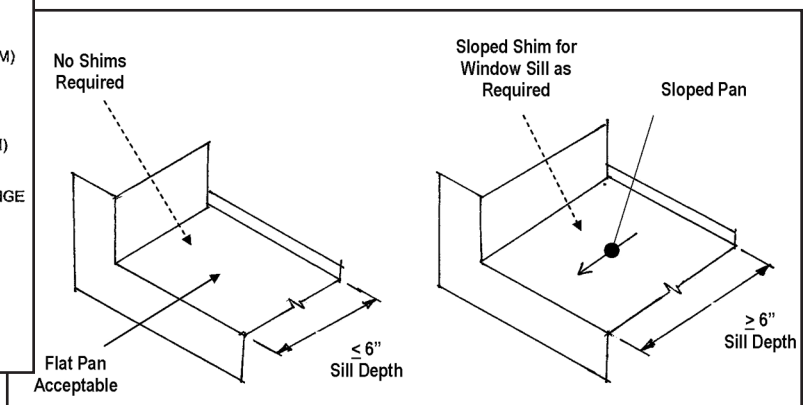

Figure 4 - Flat and sloped sill pans.

manage water infiltration from different source locations (see *Figure 5*). The ASTM E 2112 definition for pan flashing includes an important defining note.

Note - Pan Flashings have upturned legs at the interior edge and ends of the rough opening to form a three-sided pan. They are intended to collect and drain water toward the exterior, including water that may enter through the window unit (for example, between the jambs and sill) or around the window (between the rough opening and the fenestration).

Sloped vs. Flat Sill Pan

ASTM recommends that the pan portion of the sill pan flashing slope towards the outside in order to promote drainage. It also recognizes the practicality of window and door installations that need to be installed plumb and level (see *Figure 4*). The bottoms

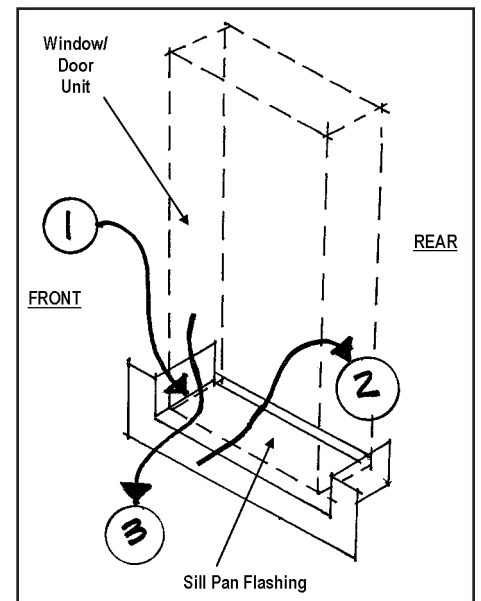

Figure 5 - Sill pan flashing collects and drains water from different sources.

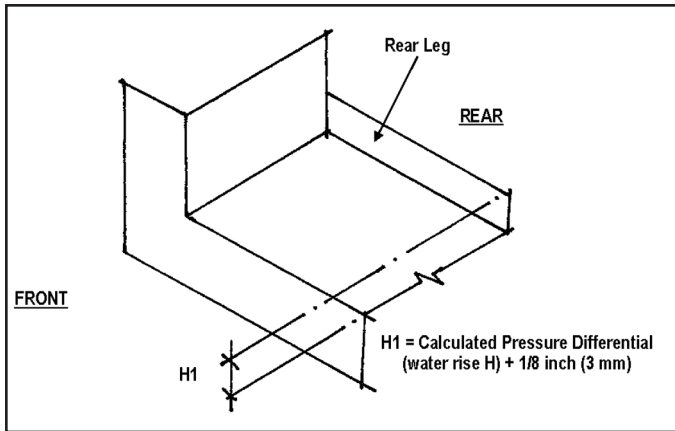

Figure 6 – Sill pan with rear leg height H1, (ASTM E 2112-07, Figure A3.1).

of most modern fenestration units are flat and typically installed to sit on a flat sill rough opening. So a sloped pan would require a sloped shim to support the fenestration unit with a flat sill bottom. The ASTM document recognizes that flat sill pan flashings up to and including a 6-in depth can be effective, so slope is only recommended and not required. When sill pan depths are greater than 6 in, ASTM E 2122-07 requires the pan to slope. So sloped shims would also be required for deep fenestration units with flat sill bottoms.

Three-Sided Pan with Front and Side Flanges

The ASTM E 2112-07 and E 2266-04 standards define a complete sill pan flashing. Other sill protection techniques that do not incorporate all the parts of the pan risk leakage. A complete sill pan flashing provides a method for controlling water intrusion from several sources of leaks, including:

1. Water entry around the window/door unit into the rough opening.
2. Water entry through the window/door unit through weatherstripping or overtopping sill tracks.
3. Leaks from window/door unit frame joinery.

A complete sill pan flashing assembly can manage the incidental water from these sources (see Figure 5). Excessive leakage may overwhelm the capacity of a sill pan.

Rear Leg Height

ASTM E 2112 describes the concept of pan flashing performance related to the capacity of the pan to resist windblown rain pressure. The pressure of the wind to drive

pan flashing that has a high rear leg height (see Figure 7).

WHAT'S BAD

Along with the good information available for reference concerning sill pan flashings, there still remains and continues to be introduced some bad news (or, more accurately, news presented badly).

Confusing Code Language

The latest IBC requires weather protection, window and door installation instructions, and particular instances of flashing. However, by being both general and specific, the building code is likely to generate confusion for both the design profession and the construction industry. Satisfying code requirements will likely evolve as code-acceptable building plans and detailing practices develop.

The 2006 IBC code, section 106.1.3, requires construction documents “include manufacturer’s installation instructions that provide supporting documentation that the proposed penetration and opening details described in the construction documents maintain the weather resistance of the exterior envelope.” Does this mean building plans need to include copies of window and door manufacturer’s cut sheets on the plans? Are manufacturers required

or draw water “uphill” is resisted by the height of the rear leg of the pan. Appendix A3 of ASTM E 2112 lists pressure differentials and the corresponding rear leg heights noted as H1 to prevent leaks overtopping the pan (see Figure 6).

Implied but not stated is the opportunity for a low-performance window/door to be backed up with a high-performance sill

to design specific instructions for a specific project? Will reference in the project specifications to the manufacturer’s general recommendations no longer suffice?

Misleading Standard

ASTM E 2112 can be easily reviewed by construction experts to find miscellaneous inconsistencies, some conflicts, and many unevenly developed sections, in the author’s opinion. Examples of compromises made in the original edition that were not revisited between the 2001 edition and the updates to the 2007 edition are noted below.

Sill Protection for Doors

One traditional and accepted method of providing sill protection at door thresholds (sills) is to bed the door threshold in beads

of sealant or in a full, solid bed of sealant. This technique is not fully described and explained in E 2112. There are a number of considerations to review before using this technique. Unfortunately, the ASTM E 2112 document shows some ineffective water management features regarding the sealants applied at thresholds. The sill pan flashing for doors is problematic (See Figure 8).

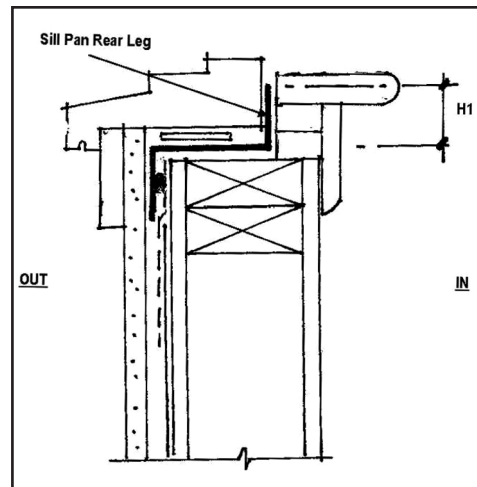

Figure 7 – Sill pan rear leg height, (ASTM E 2112-07, Figure A3.2).

Door Threshold Sealant Problems:

- The type of sealant must adhere to doorframe and substrate. The type of threshold can vary and needs to be appropriate for sealant use.
- Placement of beads of sealant must be continuous and sufficient to maintain contact with the irregular shapes of the bottom of milled wood and extruded aluminum thresholds.
- Placement of sealant may trap moisture originating behind the line of sealant under the sill if not allowed to drain.
- Placement of sealant may not capture leaks originating from frame corner joinery.
- Doorframes can have thresholds preattached to jambs, which result

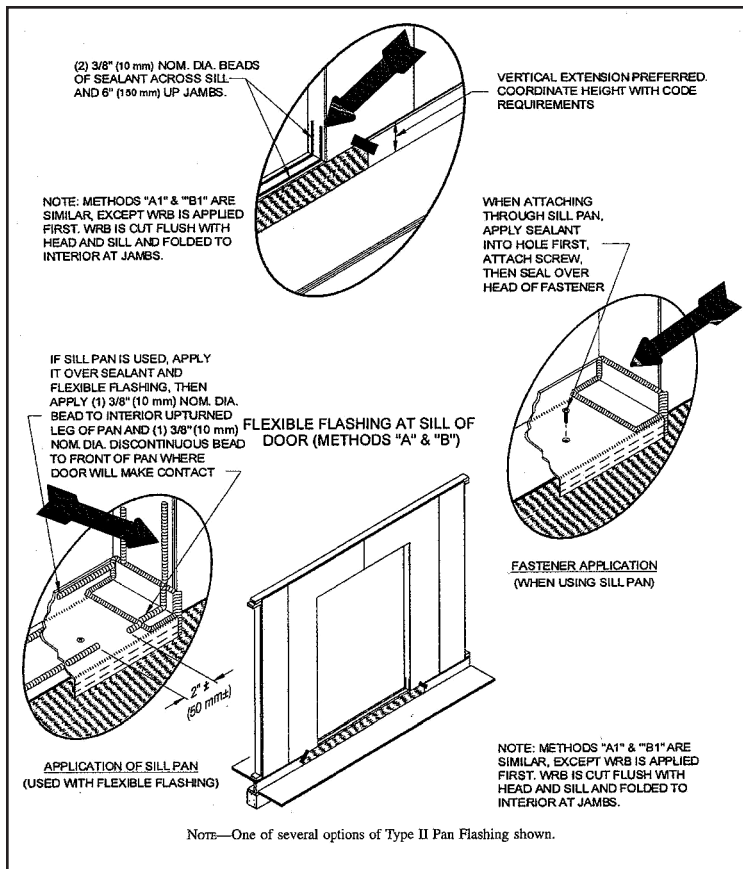
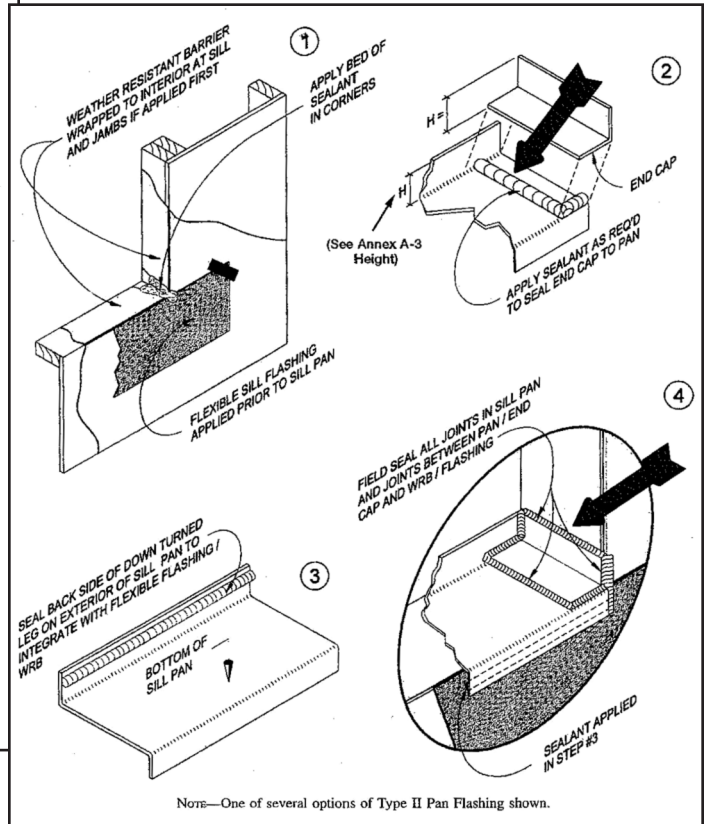

Figure 8 – Sill pan seal at rough opening (excerpt from ASTM E 2112-07, Figure 13).



in the sealant upturn per ASTM at the jamb rough opening left unadhered to the doorframe. The sealant upturn placed at the rough opening and the jamb of the doorframe is spaced away from contact with the sealant.

- Doorframes assembled on site can have the threshold applied after the jambs, which leaves the threshold-to-jamb joint unsealed unless specifically included with flashing instructions.

Pieced Sill Pan

The other sill flashing technique for doors also included in ASTM E 2112 as a method for block-frame windows consists of sealing angle pieces to the WRB to form a sill pan (see Figure 9). This technique appears to be an invention proposed for framed membrane drainage walls that was carried over in concept from applications used for storefront subsill installations in surface drainage barrier walls. There are several problems trying to make the irregular technique work for drainage walls, including:

Pieced Subsill Flashing Technique Problems:

- Relies on sealant to glue the subsill

angle pieces to the WRB at the jamb. Sealant adhesion is critical, but there are limited sealant products that can bond to both a metal or plastic subsill angle and an asphalt-based or polymeric WRB used at drainage walls.

- The flashing angle relies on a fillet bead of sealant to seal to the rough opening and to the end of the sill pan. The sealant options shown in ASTM E 2112, Table A4.1 (Appendix) do not recognize a fillet sealant bead without a bond breaker.
- The top edge of the pieced angle at the jamb is not counterflashed by other flashing or by the WRB turned into the rough opening. The lack of counterflashing breaks one of the principles of good wall waterproofing: apply waterproofing in shingle lap fashion.

In the author's opinion, these sill pan flashing methods for doors and windows shown by Figures 8 and 9 in this paper are not durable or practical for membrane drainage walls, and the examples should be removed from the ASTM standard.

WHAT'S UGLY

And to complete the references that are good and bad, there is published information that tries to be helpful but is not presented well or is incomplete. Trying to make sense of it gets ugly (read "difficult").

Building Code

The 2006 IBC code section 1405.3 on flashing includes the requirement that "[F]lashing with projecting flanges shall be installed on both sides and the ends of copings, under sills, and continuously above projecting trim." Notice the phrase "under sills." It has not been established if the IBC is requiring sill pan flashing for windows and doors. It doesn't appear that code officials are interpreting this strictly for contemporary work. The 2006 Code and Commentary, Vol. 1, by the International Code Council (ICC), provides a Figure 1405.3(3) showing a masonry through-wall flashing below a windowsill to illustrate this code section. However, is it a through-wall flashing for the masonry sill or is it a sill pan flashing for the window? The example in the ICC commentary does not include the

illustration of the option of flashing the windowsill to the water-resistive membrane, presumably on the sheathing shown inboard of the masonry.

It does not appear that the building code has anticipated the difficulty in providing specific details for many of the various types of wall constructions that are available and the many selections of windows and doors that can be installed for exterior walls.

ASTM Standard

ASTM E 2112 is intended to gather and disseminate practical knowledge. Some of the information in ASTM E 2112-07 needs to be reviewed with a high degree of professional knowledge and experience. Some of the examples of problematic presentation of information include:

- **Sealant Adhesion**

The sealants listed in the ASTM E 2112, Appendix Table A4.2, are rated as “Poor,” “Fair,” and “Good” in terms of adhesion to various construction substrates. However, the results are not uniformly consistent with the author’s experience regarding compatibility and adhesion. For example, the author believes that most silicone and polyurethane sealants perform poorly with asphalt-based WRB and the polyethylene facings of most SAF products. Specific hybrid polyurethane sealants are marketed for use with proprietary building paper and SAF. The author believes most silicone sealants also perform poorly with wood substrates and especially moist wood, whether becoming moist before or after construction. A few silicones are marketed to be compatible with and adhere to SAF. The benefits of butyl sealant as a bedding sealant for metal and plastic sill pans in concealed locations are not described.

Unfortunately, sealants are a very important component in the performance of bedding sealants and flashings for successful installation, and ASTM E 2112 does not identify the generic sealant types in many references within the standard where sealants are called for. Many details or descriptions of installations do not note that different types

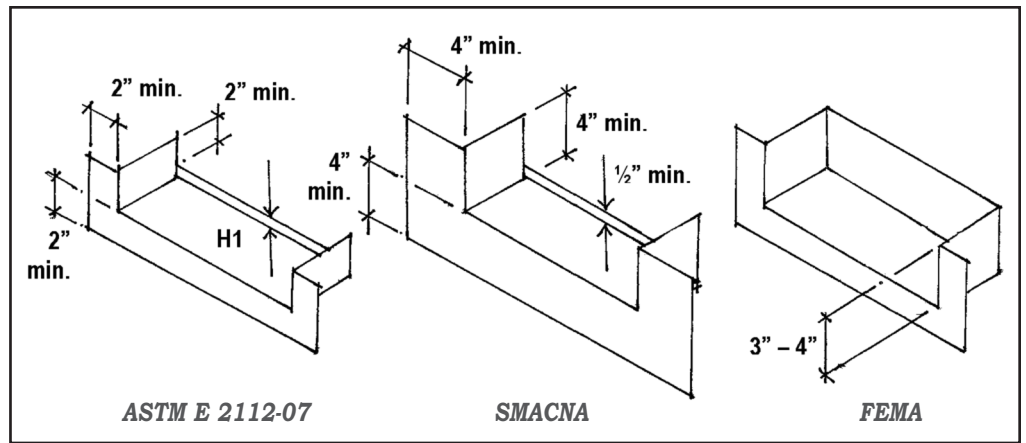

Figure 10 – Sill pan flashing dimensions.

Pan part	ASTM E 2112-07	SMACNA, 1968-2003	2007 FEMA Tech Fact Sheet No. 21
Front Flange	2 in	As necessary, 4 in at decks	Not specified
End (side) Dam	2 in	4 in	3 in - 4 in
Rear Leg (back dam)	H1	1/2-in hook	3 in - 4 in
Side Flanges	2 in	4 in	Not specified

Table 3 – Comparison of Sill Pan Flashing Dimensions, Minimum Inches

of sealants will be needed to complete one assembly. Selection of the wrong sealant can result in the failure of the waterproofing system.

A better reference for sealants is still the AAMA 850-91 Fenestration Sealants Guide. Unfortunately, it does not cover sealants used for the building substrates that make up the wall-opening interface with windows and doors.

- **Pan Dimensions**

The dimensions of sill pans shown in Figure A3.2 of the ASTM E 2112 Appendix are not consistent with the recommendations from other industry organizations. The 2-in minimum of ASTM E 2112-07 will not be adequate for certain applications with combined high winds and rain that are not addressed by the standard (see Figure 10).

It is not noted by ASTM, but the flanges of premanufactured

sill pans that have limited end dam heights and side flange dimensions can be extended by lapping strips of SAF over the edges to effectively increase the pan dimensions (see Figure 11).

Air Seals

The performance of a sill pan is similar to the performance of many windows or

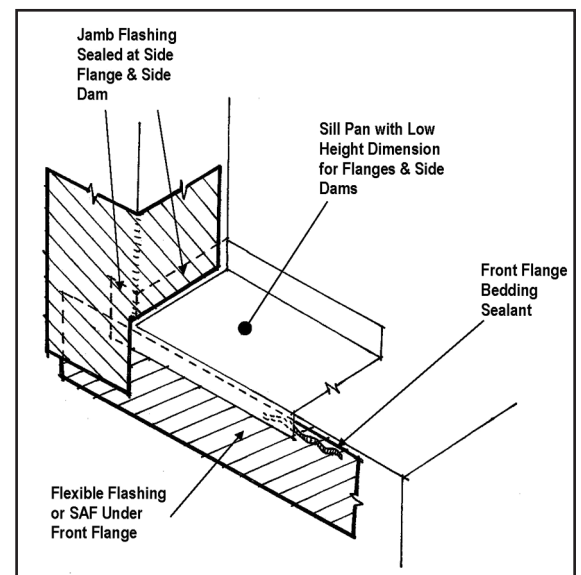

Figure 11 – Increasing pan dimensions with supplemental flashing.

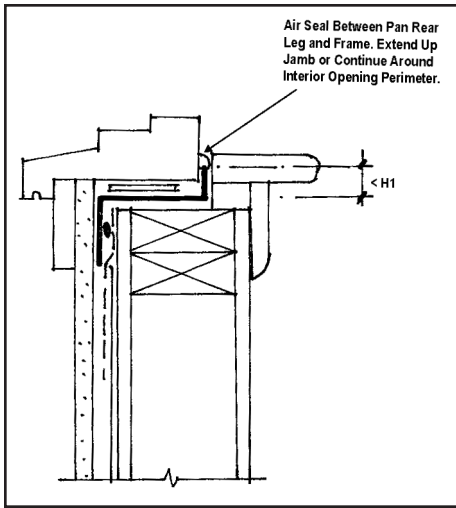

Figure 12 - Air seal reduces rear leg height.

doors in that the height of the rear leg is related to its resistance to windblown rain. Windblown rain and wind velocity vary in different geographical regions. The wind velocity generates a differential pressure against a building, wall, window, or door opening. The wind pressure “pushes” (or “pulls” from the leeward side) rainwater into joints, seams, and seals of windows/doors and the opening perimeter. The wind pressure can drive water upwards. The height of this raised water is known as “water head” or “H,” noted in inches by ASTM E 2112. The formula for equating the wind velocity [noted in miles per hour (mph)], to pressure [noted in pound per square foot (psf)], can be found in ASCE-7 and AAMA WSG.1-95. A brief table of wind velocity, pressure, and water rise values is listed in ASTM E 2112-07, Table A3.1.

So, for example, AAMA WSD.1-95 uses a hypothetical 50-mph wind, creating a pressure of 6.4 psf, which can “push” water up 1.23 inches. Therefore, a sill pan flashing’s rear leg would need to be higher (about 1 - 1¼ inches or more) in order to prevent overtopping. However, if the air path into the pan is blocked so that there is no rise in the water being forced into the pan, the pan height can be lowered. One way to accomplish a pan with lower rear leg height is to provide air seals (see Figure 12).

The concept of air seals on the interior side between pan and window/door is introduced in ASTM E 2112-07. However, it is not fully explained, described, or illustrated for nonexperts to find useful. In ASTM E 2112-07, Appendix Section A3, a small note is added after the discussion of rear leg pan height.

- Note A3.1 - Rear leg pan heights can

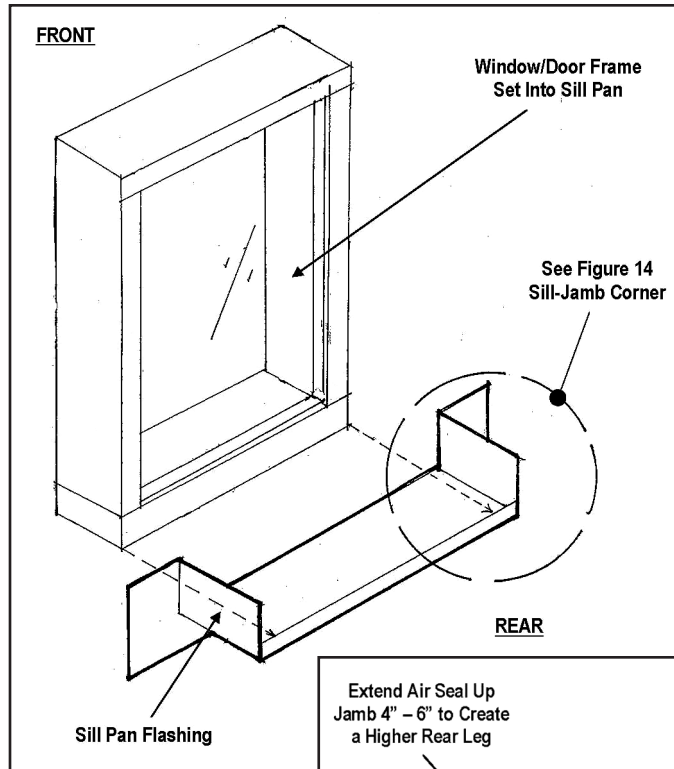

Figure 13 - Window sill pan with air seal.

be reduced by the use of continuous air infiltration seals or engineered sealant joints.

An air seal can reduce the height needed for a rear leg on a sill pan to resist a given wind pressure that would otherwise “push” or “pull” wind-blown rain over the top of the pan at the rear. A rear leg sealed to the back of the windowframe blocks air flow between sill frame and sill pan and therefore prevents water from flowing into the sill pan and breaching over the top rear leg.

The air seal has to be continuous across the back of the windowframe and extend across any gap between the ends of the sill frame and any shim space of the rough opening (See Figures 13 and 14). The air seal application can be addressed by a couple of methods.

Having a perimeter air seal around the interior (room side) of the window frame will also prevent other air infiltration to reduce energy loss. A method of providing a peri-

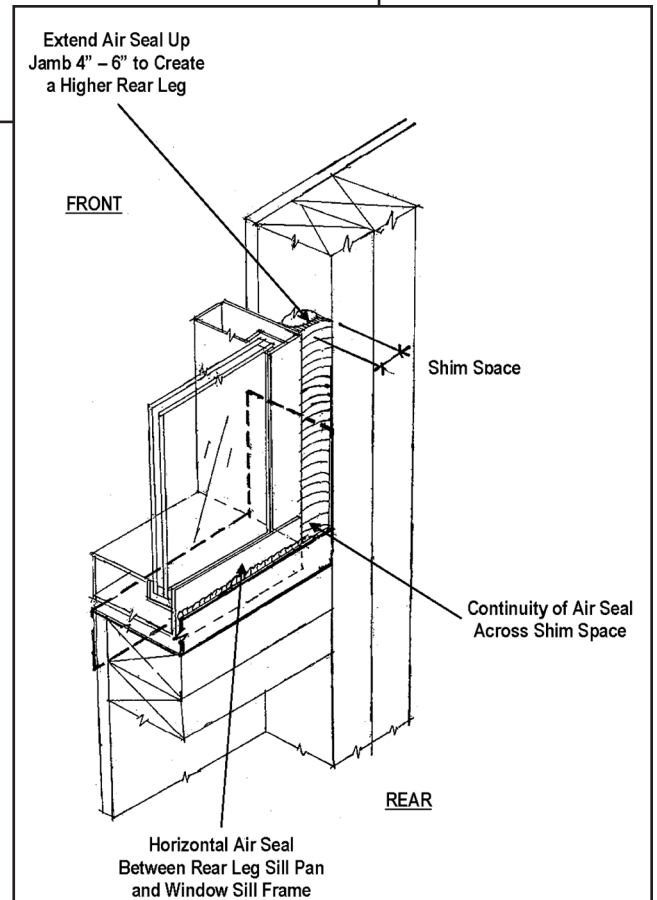

Figure 14 - Windowsill pan with air seal - extended rear leg.

meter air seal is with the use of low-expanding aerosol foam or foam tape. Urethane foams can also seal well to metal frames and most rough opening substrate materials. Foam aerosol and foam tape air seals are included in ASTM E 2112, Annex A1, but the prevention of water leakage is not discussed with the coordination of sill pans.

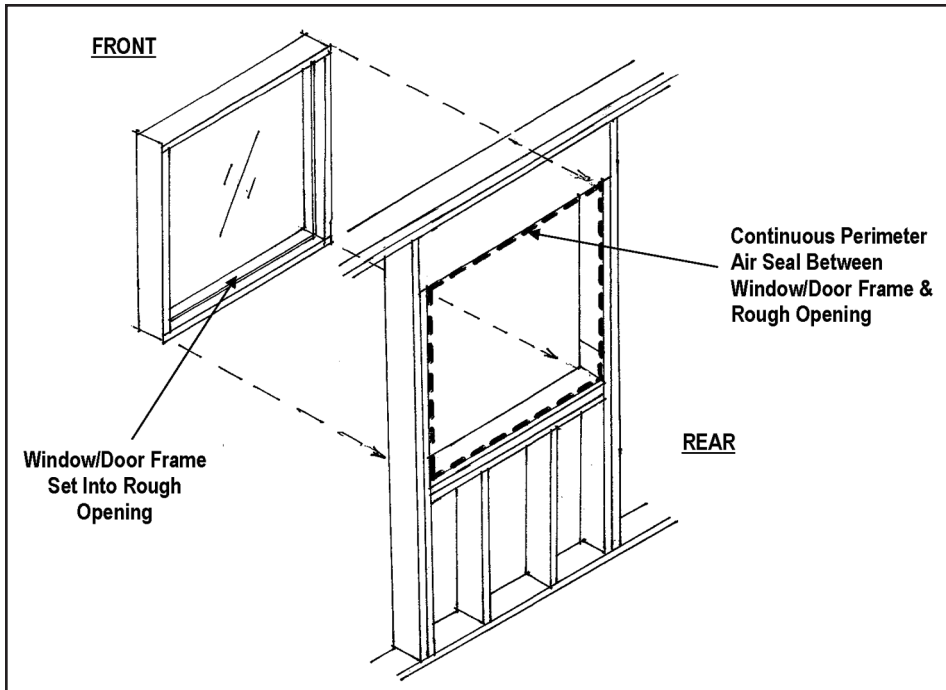

Figure 15 – Continuous air seal at interior window perimeter.

Additional backer rod and sealant extending up the vertical shim space approximately 6 in will be required to bridge across the shim space gap to effectively create an equivalent raised rear pan leg (See Figures 13 and 14). The sealant will need to adhere to the frame jamb and end dam of the pan at the side of the rough opening. Having the pan end dam dimension extend up at least 4 to 6 in can provide a better substrate for the air seal adhesion than wood framing or other nonmetal sheathing material.

A continuous perimeter air seal provided by low-expanding foam, tape, or sealant also blocks the rise of water in the sill pan. It has the advantage of completing the air-infiltration blockage needed to have a continuous air barrier system as part of the wall assembly (see Figure 15).

With the recommendation for all window and doors to have sill pan flashings, there was no recognition that the sill pan drainage challenges are different with block frame and mounting flange (a.k.a. nail-fin or nail-on) frames. The drainage of the sill pan flashing with a block frame unit is described and shown in E 2112 with a discontinuous bead of sealant at the forward edge. But the nail fin installation was not described or shown in the ASTM standard.

In order for a sill pan to drain when using a nail-fin frame, the joint between them needs to open. This can be accomplished in several ways. The perimeter bed-

ding sealant typically applied behind the mounting flange can be omitted along the sill; holes or slots in the sill flange can be drilled or cut (with the manufacturer's permission), and the sill fin of doors can be ordered to be removed at the factory or field cut (with manufacturer's permission). A practical method of allowing drainage is to provide intermittent shims between sill flanges and sill pan front flanges. Solid plastic shims set in sealant or strips of SAF through which fasteners are driven can be

applied behind the mounting flange (See Figure 16).

CONCLUSION

Sill pan flashing is currently being reconsidered by the construction industry as a necessary backup to windows and doors for low-rise residential and light commercial buildings, although debate continues on whether or not it must be universally required. A sill pan flashing for windows and doors can certainly be included to improve the water-resistance performance of all building types.

Despite the good, the bad, and the ugly, the 2006 IBC and ASTM E 2112 can be useful references for important flashing information. Designers, specifiers, and builders can use ASTM E 2112 to recognize many important concepts and features when deciding to include a sill pan flashing for a strategy to improve the performance of perimeter wall opening flashings.

Other methods are available besides what's included or is not fully explained by ASTM E 2112. Some advice needs to be independently judged and sorted out by knowledgeable professionals. This paper is intended to point out some of the positive and negative aspects of the information currently available from the author's perspective as an insider helping to develop industry standards. The Field Guide portion of this paper can illustrate how the concepts in ASTM E 2112 can be implemented and how the sill pan flashings can be incorporated into various types of construction. 

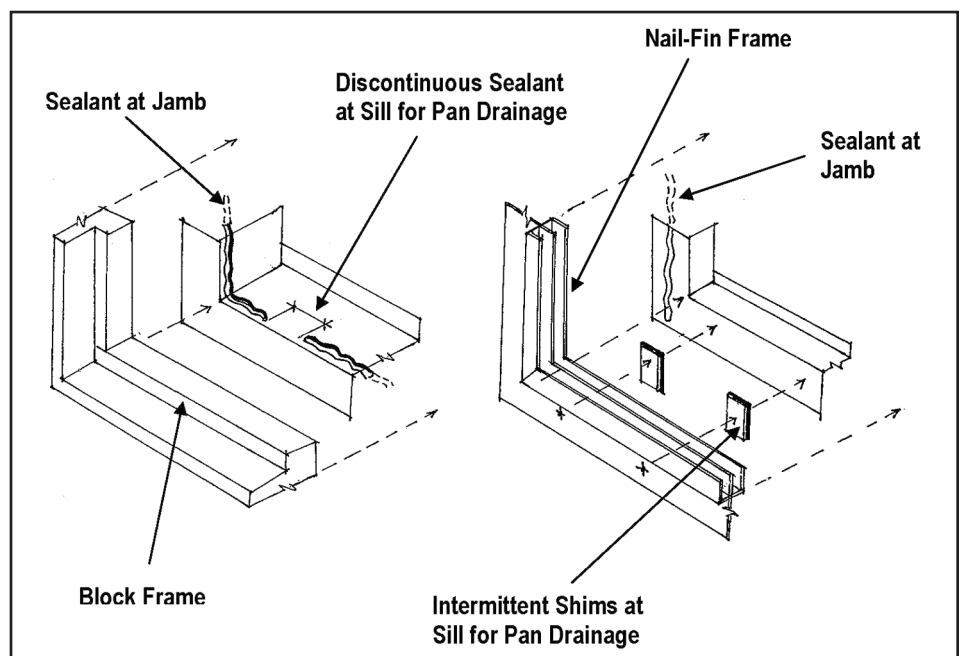

Figure 16 – Block frame and nail-fin frame drainage at sill pan flashing.

REFERENCES

The author was involved in the CAWM committee that issued CAWM 400-95 and CAWM 410-97. He participated as a member of the ASTM Task Group E6.51.11, which developed ASTM E 2112 and witnessed the evolution of the document for 10 years. The opinions expressed here are solely the responsibility of the author.

The following references are useful for studying the subject of flashings and sill pans.

2006 *International Building Code*, International Code Council, Country Club Hills, IL, www.iccsafe.org.

2006 *International Building Code and Commentary*, Vol.1, Country Club Hills, IL, www.iccsafe.org.

AAMA 711-05, *Voluntary Specification for Self-Adhering Flashing Used for Installation of Exterior Wall Fenestration Products*, 2005, AAMA, Schaumburg, IL, www.aamanet.org.

AAMA 850-91, *Fenestration Sealants Guide*, 1991, AAMA, Schaumburg, IL, www.astm.org.

AAMA 2400-02, *Standard Practice for Installation of Windows with a Mounting Flange in Stud Frame Construction*, 2002, AAMA, Schaumburg, IL, www.astm.org. This standard was based on CAWM 400-95 but omitted the critical requirement for the vertical edges of the WRB to be sealed along the window jamb.

AAMA 2410-99, *Standard Practice for Installation of Windows with a Mounting Flange in Stud Frame Construction*, 2002, AAMA, Schaumburg, IL, www.astm.org. This standard was based on CAWM 410-97.

AAMA IM-TM, *Installation Masters Training Manual*, 2000, AAMA, Schaumburg, IL, www.aamanet.org. This manual was based on the pre-publication work of ASTM E 2112-01. It includes more background

information directed towards window installers

AAMA WSG.1-95, *Window Selection Guide*, 1995, AAMA, Schaumburg, IL, www.astm.org.

Architectural Sheet Metal Manual, 1965 (1st ed.), 1968, 1979, 1987, 1993, 2003 (6th ed.), SMACNA, Chantilly, VA, www.smacna.org.

ASTM E 2112-01, *Standard Practice for the Installation of Exterior Windows, Doors, and Skylights*, 2001, ASTM International, Conshohocken, PA, www.astm.org.

Robert Bateman, "Designing and Specifying Self-Adhering Flashings for the Window Wall Interface," *Journal of ASTM International*, Nov./Dec. 2005, Vol. 2, No. 10, www.astm.org.

Robert Bateman, *Nail-on Windows - Installation and Flashing Procedures for Windows & Sliding Glass Doors*, 1995, DTA, Inc, www.buildersbooks.com.

Robert Bateman, "Sill Pan Flashing for Block-Frame Windows in Recessed Concrete Openings - Case Studies," *Journal of ASTM International*, March 2008, Vol. 5, No. 3, www.astm.org.

T. K. Butt, "Window Installation - An Evolving Challenge," November 8, 2004, unpublished manuscript, Interactive Resources, Inc., Pt. Richmond, CA, www.intres.com.

CAWM 400-95, *Standard Practice for Installation of Exterior Windows with Integral Mounting Flange in Wood Construction*, 1995, CAWM (defunct and some members reorganized into AAMA, Western Region), Los Angeles, CA. See AAMA 2400-02 for similar but not identical standard.

CAWM 410-97, *Standard Practice for Installation of Sliding Glass Doors with Integral Mounting Flange in Wood Construction*, 1997, CAWM (defunct and some members reorga-

nized into AAMA, Western Region), Los Angeles, CA. This standard illustrates different sill pan flashings.

R. W. LaTona and T. A. Schwartz, "Against the Wall," *Architecture Magazine*, May 1990. www.sgh.com. *Residential Sheet Metal Guidelines*, 2001, SMACNA, Chantilly, VA, www.smacna.org.

S. S. Ruggiero and J. C. Myers, *Design and Construction of Watertight Exterior Building Walls*, 1992, ASTM STP 1107, ASTM International, Conshohocken, PA, www.astm.org.

"Walls - Avoiding Moisture Accumulation in Walls," Form A530A, revised October 2002, APA, Tacoma, WA, www.apawood.org.

Window and Door Installation - Homebuilders Guide to Coastal Construction, Technical Fact Sheet No. 21, circa 2007, FEMA, www.fema.gov.

FOOTNOTES

1 ASTM E 2112-07, *Standard Practice for the Installation of Exterior Windows, Doors and Skylights*, 2007, ASTM International, Conshohocken, PA, www.astm.org.

2 ASTM E2266-04, *Standard Guide for Design and Construction of Low-Rise Frame Building Wall Systems to Resist Water Intrusion*, 2004, ASTM International, Conshohocken, PA, www.astm.org.

3 "Laboratory and Field Evaluation of Pan Flashing/Sill Protection and Water Resistive Barriers," April 2006, Williams Building Diagnostics - NAHB Research Center, Inc., PATH/HUD, Washington, DC, www.huduser.org and www.pathnet.org.

APPENDIX 1 (Continued)
TYPES OF SILL PAN FLASHING – FABRICATION

(Based on ASTM E 2112-07, Table 5)

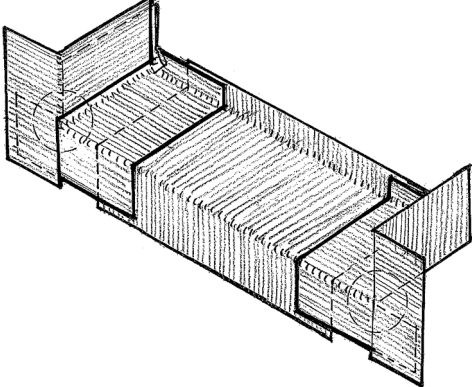
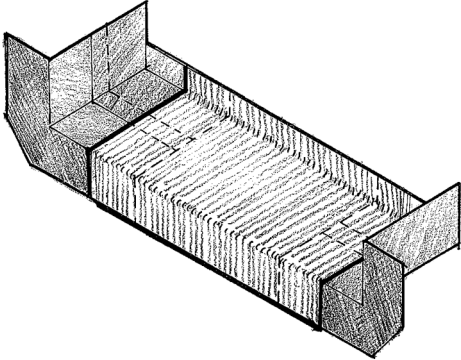
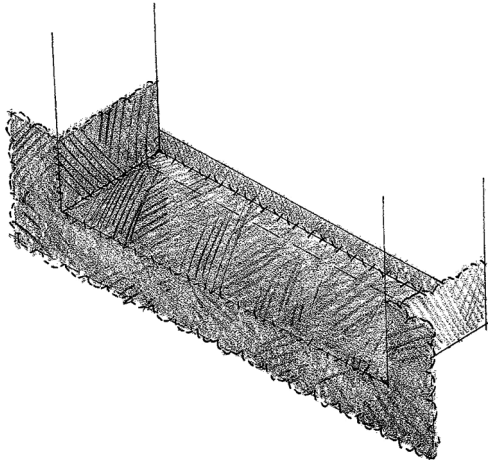
Type	Material	Fabrication	Diagram
Type III	Flexible membrane – self-adhering flashing	Multiple pieces, membrane pieces lapped watertight	
Type IV	Combination – rigid + membrane flashing	Multiple pieces – usually formed rigid corners joined with lapped self-adhering membrane sheet(s)	
Type V	Liquid – membrane coating	1-piece: spray-, brush-, or roller-applied coating applied directly to the substrate. Note: integrate with any separate flashing & WRB	

Appendix 2 FIELD GUIDE TO SILL PAN FLASHING

There are various types and shapes of sill protection and different methods of constructing and installing a sill pan flashing for windows and doors. The Field Guide shows some of the examples of the various types of sill pan flashings used for windows and doors in various types of wall openings and combined with various wall claddings.

Field Guide Notes:

Concealed – refers to a sill pan that is under the wall cladding and integrated with a drainage-type water-resistive barrier (WRB)

Direct Drain – refers to a sill pan that drains under the window/door immediately to the outside of the exterior wall cladding and can be used with barrier walls or drainage walls



GSM – galvanized sheet metal





SAF – self-adhering flashing





Type I, II, III, IV – refers to ASTM E 2112-07, Table 5



Type V – refers to Table 1 liquid membrane coating (Appendix1)

WRB – water-resistive barrier

FIELD GUIDE to SILL PAN FLASHINGS		
	Type & Description	Photo
1	Type III - SAF pan – concealed for nail-fin window in recessed metal siding opening	
2	Type I - GSM pan – direct drain for block-frame window in recessed stucco opening	

Type & Description	Photo	
3	Type I - GSM pan – concealed for block-frame window in recessed stucco opening	
4	Type I - Aluminum pan and sill cover – direct drain for block-frame window in recessed stucco opening	
5	Type I - GSM pan – concealed for block-frame door in flush stucco opening and elastomeric deck	
6	Type I - GSM pan – direct drain for block-frame window in concrete opening	

Type & Description	Photo	
7	<p>Type I - GSM pan – concealed for block-frame window in recessed stucco opening</p> <p>Type III SAF sill pan under the metal pan</p>	
8	<p>Type III - SAF pan – concealed for block-frame window in recessed stucco opening</p>	
9	<p>Type III - GSM pan – direct drain for block-frame window in masonry opening</p>	
10	<p>Type IV - Stainless steel pan corners and separate rear leg with neoprene sheet membrane center section and urethane deck coating</p> <p>Block-frame sliding glass door in recessed stucco opening</p>	

Type & Description	Photo
<p>11</p> <p>Type III - SAF concealed for block-frame window in metal panel cladding Aluminum sill cover [protection over pan flashing]</p>	
<p>12</p> <p>Type III - SAF pan concealed for block-frame window in brick veneer cladding Aluminum sill cover protection.</p>	
<p>13</p> <p>Type III - SAF pan concealed for block-frame window in recessed stucco opening Aluminum sill cover protection.</p>	
<p>14</p> <p>Type V – Liquid-applied sill protection to flush opening A Type I – multiple pieces pan will go over the sill</p>	