

Snow and Ice on Sloped Roofs: Shed it or Keep it on?

BY TERRY ANDERSON

HOW WOULD YOU ANSWER THIS question? If you are like most roofing consultants, you would reply based upon a number of factors. One factor would be your experience as a roofing expert. Another would be where you live and work. Another factor would be your training. If you are from North America you would probably respond "shed it off." Our approach in North America is to use a metal roof with a steep slope that will allow the snow and ice to slide off. Why do we design this way? The primary reason is a fear of having the building collapse under a heavy snow load.

If you lived in Europe, however, your training and experience would be notably different. For instance, a roofer in Germany must apprentice before he can become a journeyman. (This compares to our weekly union program that involves very little training on sloped roofs in snow climates.) A German apprentice's training includes classroom and on-site work. Manufacturers sponsor training and provide detailed reference books and manuals. One key difference in the industry's approach to snow on roofs is that keeping snow on the roof is something that they desire—quite the opposite approach from the trend in North America. They would say "use a



Many European tile manufacturers make field tiles with snow stops as part of the tile.

low slope (approximately 5/12) and keep the snow on."

In an effort to solve the problems associated with moving snow and ice, I have heeded the experience and resources of the European construction industry and have implemented their ideas with great success. Here are some of the key factors in their approach to keeping snow on the roof.

Germans in general are not concerned with snow loads because they design the structure to hold the live load. Designers there want the architectural freedom to have access around the building. They also plan to use the snow as an insulation blanket and design a cold roof system to stop ice dam concerns at the eave. The slope that works best seems to be 5 / 12. This allows the snow to stay on while venting the roof system. They then have the option of putting dormers on the roof without damage to the valleys, penetrations, lower roofs, and property below due to sliding snow and ice.

To complete this roof system, snow stops (or snow brackets) are used to stop all snow movement. In Europe the majority of roofs are tile. Many of the tile manufacturers make field tiles with snow stops as part of the tile. (See tile photo.) Through extensive testing, they have found the snow stop's

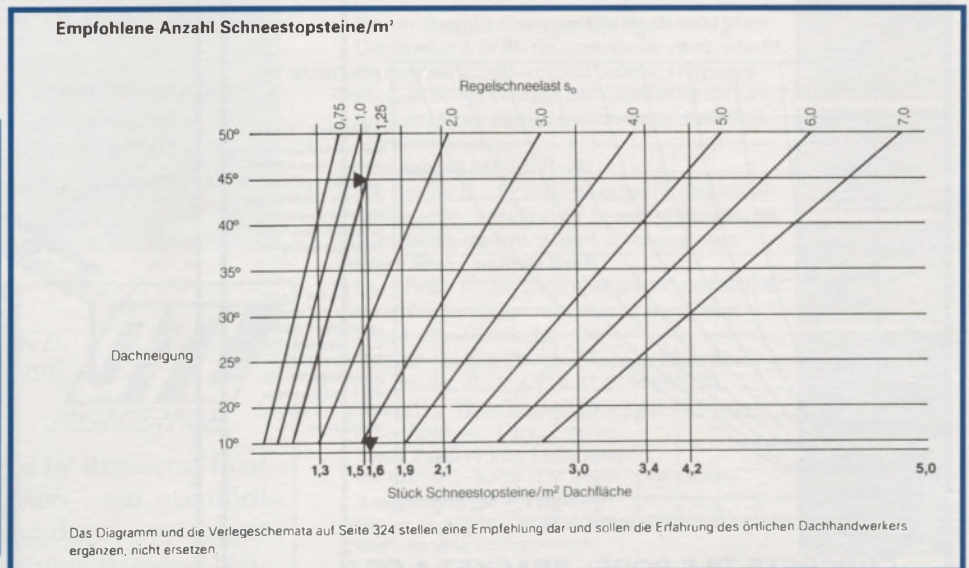

German chart to help consultants calculate how many snow stops are needed from eave to ridge based on roof slope.

failpoint. Once they know this, they engineer charts which help the consultants calculate how many snow stops are needed from eave to ridge based on roof slope and snow and ice loads to effectively hold the snow and ice on the roof. With this information, European designers create roofs that effectively hold the snow and ice in place, as well as preventing roof damage and breakage. (See German chart, page 25.)

I have found that if you want to stop damage to the roof from snow and ice, you must stop movement. Snow fences do not do this, but properly placed snow brackets do. In my research, I have found different conditions which require snow fences and/or snow brackets. Snow brackets stop the movement of the snow on the entire roof. They are typically installed over the entire roof. Snow fences are meant to stop top-layered snow from sliding off like an avalanche over doorways. These snow fence brackets normally attach to the rafters on two-foot centers. If the eave-to-ridge length is over 20 feet, European designers usually place another snow fence row mid-span. Both snow retention items are sometimes necessary. But without designing the snow retention based on accurate testing, you could be wishing you had that steep slope and metal roof (which was always intended to shed snow). It is critical that a designer specify enough snow retention devices based on the slope and snow load.

It makes sense when designing a metal roof to shed snow, not to keep it on. With expansion and contraction of the metal, it is difficult to attach snow retention devices into the roof decking without causing a roof leak or slotting of the metal panel from the snow bracket fastener. If you attach only to the metal, the metal sheets can be torn off because of the use of the expanding sheet clip system and the weight of the snow being held on.

The following roof types are good for keeping snow on:

1. Tile
2. Asphalt shingles
3. Wood shakes
4. Slate

When using these types of roofs, it is important to know which climate type you are in (i.e., number of freeze-thaw cycles and altitude) and how to control vapor drive and ice damming. These factors will make a difference in the roof design. A cold roof system which controls these factors is the ideal roof system. In the cold regions of Europe, the roofers have manuals with detailed specifications, details, graphs, and

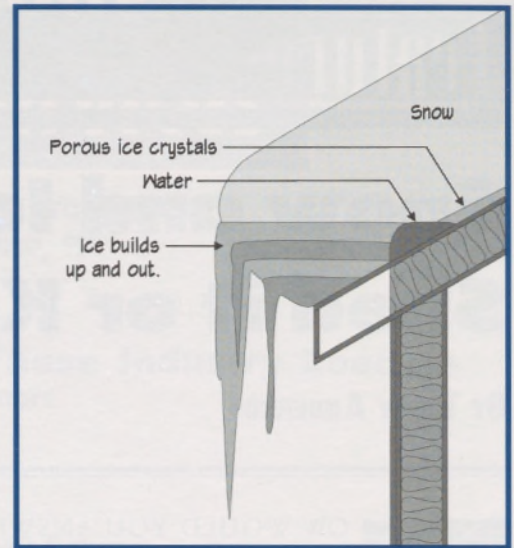

Icing at eaves.

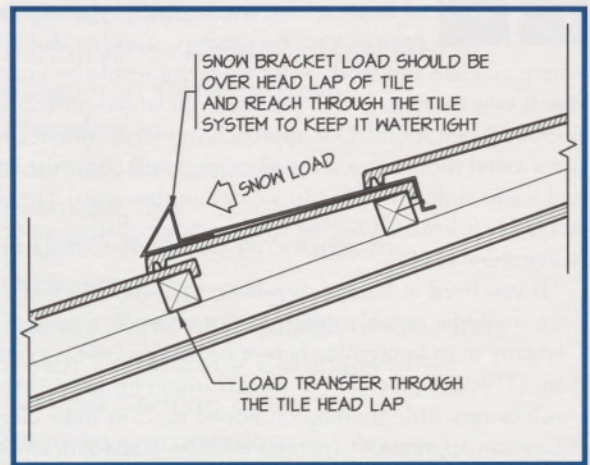

Snow bracket load should be over head lap of tile and reach through the tile system to keep it watertight.

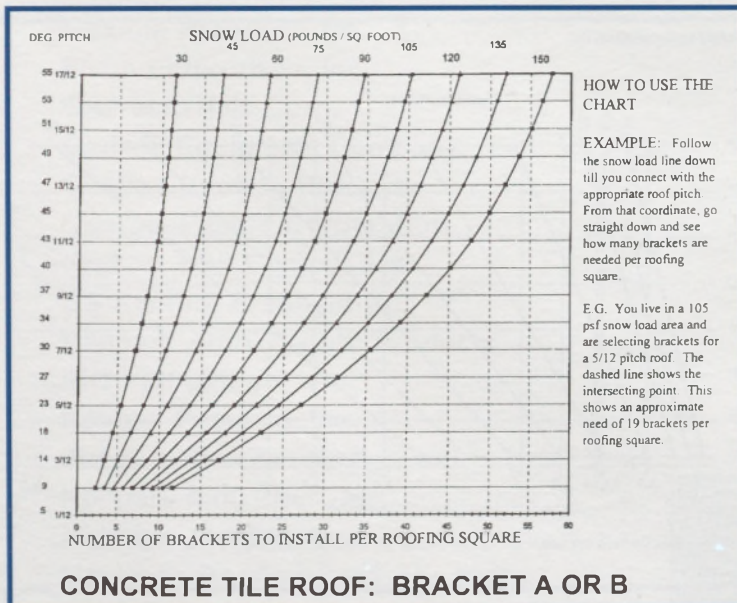

Number of brackets needed per roofing square. Courtesy, Tile Roof Accessories.

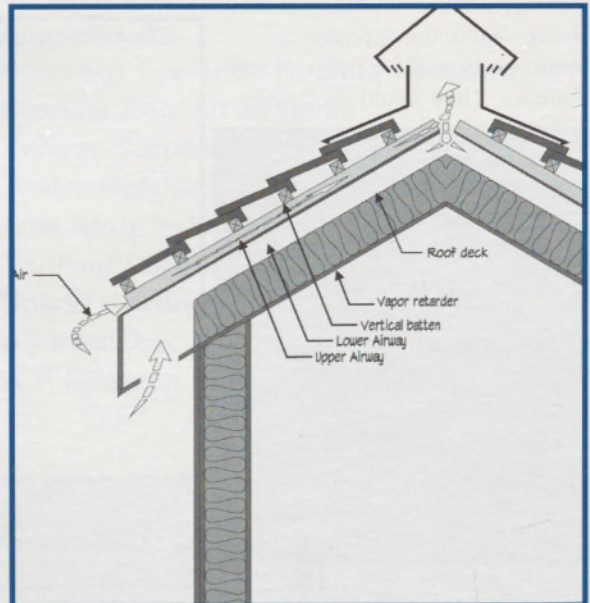

Features of a simple cold roof.

charts which explain cold roof systems and how to successfully install them. This is one reason keeping the snow on the roof is such a widely accepted practice—the roofs are planned for it and installed correctly. In the U.S., there is a new manual on roof applications in heavy snow areas prepared by the Western States Roofing Contractors Association (WSRCA) and the National Tile Roofing Manufacturers Association (NTRMA). This manual promotes the cold roof system and snow retention.

As I design roofs today in ski resort areas, I use one of the above types of roofs and plan to keep the snow on. I vent the roofs for many reasons:

1. To reduce ice dams and icicles.
2. To exhaust vapor from the building.
3. To extend the life of the underlayment.
4. To provide an insulation blanket on the roof.

I follow Austrian venting charts for duct work size from eave to ridge. I also pay close attention to air intake and exhaust size because many screens reduce air flow by up to 70%. Then I install snow brackets and snow fences on the roof per manufacturer's engineering design from eave to ridge. With this I have had great success in Sun Peak, Canada; Grand Targhee, Wyoming; Beaver Creek, Colorado; Sundance, Utah, and many more.

Note: This year a manual called Concrete and Clay Tile Roof Design Criteria Manual for Cold and Snow Regions was commissioned by NTRMA and WSRCA. The manual helps determine the climate type and explains what design factors are important in the given zone. It also explains essen-

About the Author

Terry Anderson has been involved in the roofing industry for 20 years and is the owner of Anderson Associates Consulting in Highland, Utah. He is a member of RCI, WSRCA and NRCA. Anderson also serves on the committee for tile roof applications in snow and ice areas for NTRMA and WSRCA. He recently finished co-authoring their new manual, *Concrete and Clay Tile Roof Design Criteria Manual for Cold and Snow Regions*. Anderson has conducted research in Europe and has reported some of his findings in this article. For more information, please contact Terry Anderson at (801) 756-9811.



Terry Anderson

tials such as ice damming, vapor drive, and ventilation for cold roofs and includes venting charts. For further information, phone WSRCA at (650) 548-0112.

References:

- Anderson, Terry, and Gillan, Leland, *Concrete and Clay Tile Roof Design Criteria Manual for Cold and Snow Regions*, WSRCA & NTRMA, 1998.
- Braas Tile Venting Manual
- Bramac Brochure on Venting, March 1996
- Redland Roof Tiles Limited, 1998
- WSRCA / NTRMA Cold Roof Committee
- Zander Tile Roof Installation Book

Majoring in Construction in High School

A new charter high school dedicated to construction has opened in the Detroit public school system. The Michigan Institute for Construction Trades & Technology will teach carpentry, plumbing, masonry, and electrical work.

RoofManager

Roof Asset Management Program



Finally, a roof database developed by Registered Roof Consultants, Owners, Contractors and certified software developers. Call for your demo copy or visit our web site at www.prophead.com/RoofManager.htm.

CTL Engineering, Inc. 704-553-8285

TRA Tile Roof Accessories

THE SNOW RETENTION SPECIALISTS!

SNOW BRACKETS AND SNOW FENCES

New or Retrofit Concrete Tile Roofs

Use Bracket A or B - for concrete tile roofs which are installed using horizontal battens. Only snow retention device available and patented for tile roofs! No penetrations through underlayment. Retrofit or new construction.



New Asphalt Shingle Roofs

Use Bracket D - for standard or metric new asphalt shingle roofs. Installs under courses of shingles, no fasteners are exposed. Uses 4 2" roofing nails.



Wood Shake or Slate Roofs

Use Bracket F - for wood or slate new construction. Installs under courses, no fasteners are exposed. Uses 4 2" roofing nails.



Retrofit Asphalt Shingle, Shake or Slate Roofs

Use Bracket G - in 8.5" to 11.5" lengths OR Bracket H. These brackets have a slip-on covers to shield fasteners. Uses 2 screws.



Metal Panel or Flat Seam Roofs

Use Bracket G - 8.5" to 11.5" lengths. Uses 2 screws.

Avalanching Snow Problems

Use our snow fences. Various designs available. Interlocks under roofing product.



(801) 756-8666 - FAX (801) 756-7891

Internet - www.TRAsnowbrackets.com - e-mail - tra@enol.com

EVERY ROOF IS UNIQUE! LET US KNOW THE SLOPE AND SNOWLOAD AND WE'LL DESIGN A LAYOUT SPECIFICALLY FOR YOUR ROOF!